



HYDRO TRACTOR

Parts Manual

Models
936053 46" Hydro Tractor



GB ENGLISH

532 44 30-25 (21547838C) Rev 3 05.29.13
Printed in the U.S.A.

HOW TO USE THIS MANUAL

This manual is designed to provide the customer with a means to identify the parts on his/her tractor when ordering repair parts. The illustrations may or may not represent the actual assemblies; therefore, it is not recommended to use this manual as a guide to assemble or disassemble the tractor. Some hardware and parts are drawn larger in order to more readily identify them.

Each tractor has its own model number.

The model number for your tractor can be found on the fender under the seat.

When ordering parts, always give the following information:

- Product - "Tractor"
- MODEL NUMBER - "936053 (96046002602)"
- Part Number
- Part Description

TABLE OF CONTENTS

SCHEMATIC	3
ELECTRICAL.....	4-5
CHASSIS	6-7
DRIVE.....	8-9
ENGINE.....	10-11
STEERING	12-13
MOWER DECK	14-15
MOWER LIFT.....	16-17
SEAT	18-19
DECALS.....	20-21
PARTS AND SERVICE.....	22

TRACTOR - MODEL NO. 936053 (96046002602), PRODUCT NO. 960 46 00-26 SCHEMATIC

SCH13

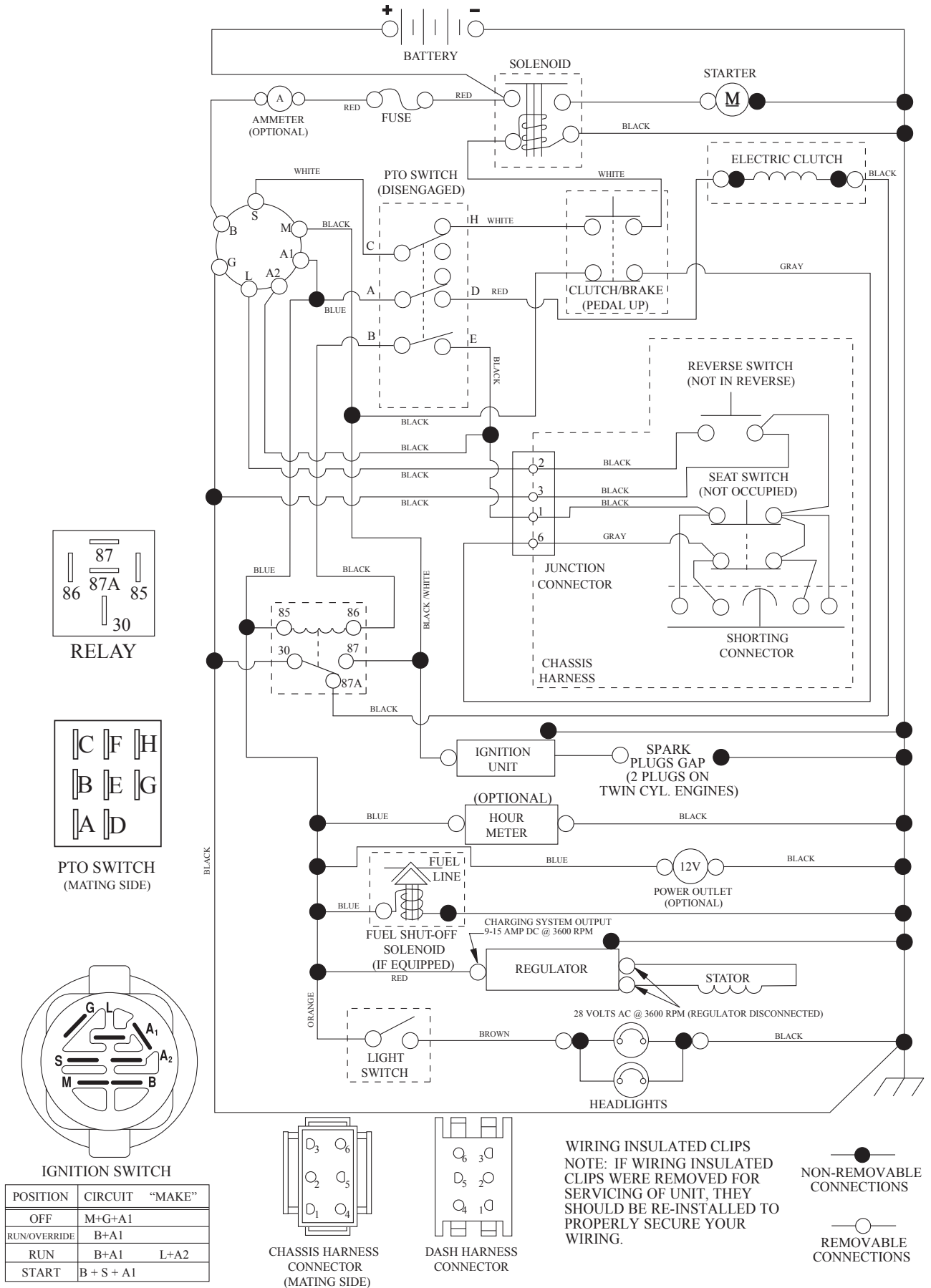

**TRACTOR - MODEL NO. 936053 (96046002602), PRODUCT NO. 960 46 00-26
ELECTRICAL**

ITEM NO.	MFG. NO.	ARIENS PART NO.	DESCRIPTION
1	532 16 34-65	21546162	BATTERY.12.VOLT.28.AMP.WET
2	874 76 04-12	21546803	BOLT HEX HD 1/4-20 UNC X 3/4
8	532 19 32-28	21546315	BOX.BATTERY.MOUNT.FRONT.LT
16	532 17 61-38	21546205	SWITCH.INTERLOCK.NONO.GRAY
21	532 17 56-88	21546226	HARNES.ASM.LIGHT.22"(4152J)
22	532 00 41-52	21546673	BULB.LIGHT.#1156
25	532 41 28-95	21547566	CABLE STARTER 6 G4. BL/RED 14.5
26	532 17 51-58	21546200	FUSE.20 AMP.
27	873 51 04-00	21546779	NUT, KEPS HEX 1/4-20 UNC
28	532 19 88-85	21546481	CABLE.BLACK.22"REAR BATT.TEX
29	532 40 15-45	21546574	SWITCH.SEAT.DELTA.OPC.9LB.
30	532 19 33-50	21546319	SWITCH.IGN.DLTA.P-IN.ROS
33	532 41 19-33	21547339	KEY/CHAIN.BLISTER PACK.GEN.CE
34	532 11 07-12	21546050	SWITCH.LIGHT/RESET.B/B/RED.
40	532 40 96-14	21547336	HARNES IGN ELEC RELAY
41	817 72 04-08	21546210	SCREW 1/4-20 X 1/2
42	532 13 15-63	21546082	COVER.TERMINAL.RED
43	532 19 25-07	21546294	SOLENOID.W/BRASS PLUNGER.2005
50	532 17 46-51	21546196	SWITCH.PTO.8 TERMINAL.BLACK
55	817 06 05-12	21546187	SCREW.5/16-18X3/4.SMGML.TAP/R
71	532 40 04-49	21546558	HARNES.IGN.CHASSIS.TEX
79	532 17 52-42	21546201	SOCKET ASM.BULB.TWISTLOCK
81	532 40 96-15	21547337	RELAY HARNES SEALED
90	532 43 53-95	21547570	COVER TERMINAL BATTERY FR. TEX
92	532 19 66-15	21546412	HARNES.PIGTAIL.CONSOLE.ROS.MLK
93	532 19 25-40	21546295	SCREW.PLASTITE.10-14 X 2.0
94	532 19 18-34	21546849	MODULE.REVERSE.ROS

NOTE: All component dimensions given in U.S. inches
1 inch = 25.4 mm

**TRACTOR - MODEL NO. 936053 (96046002602), PRODUCT NO. 960 46 00-26
CHASSIS**

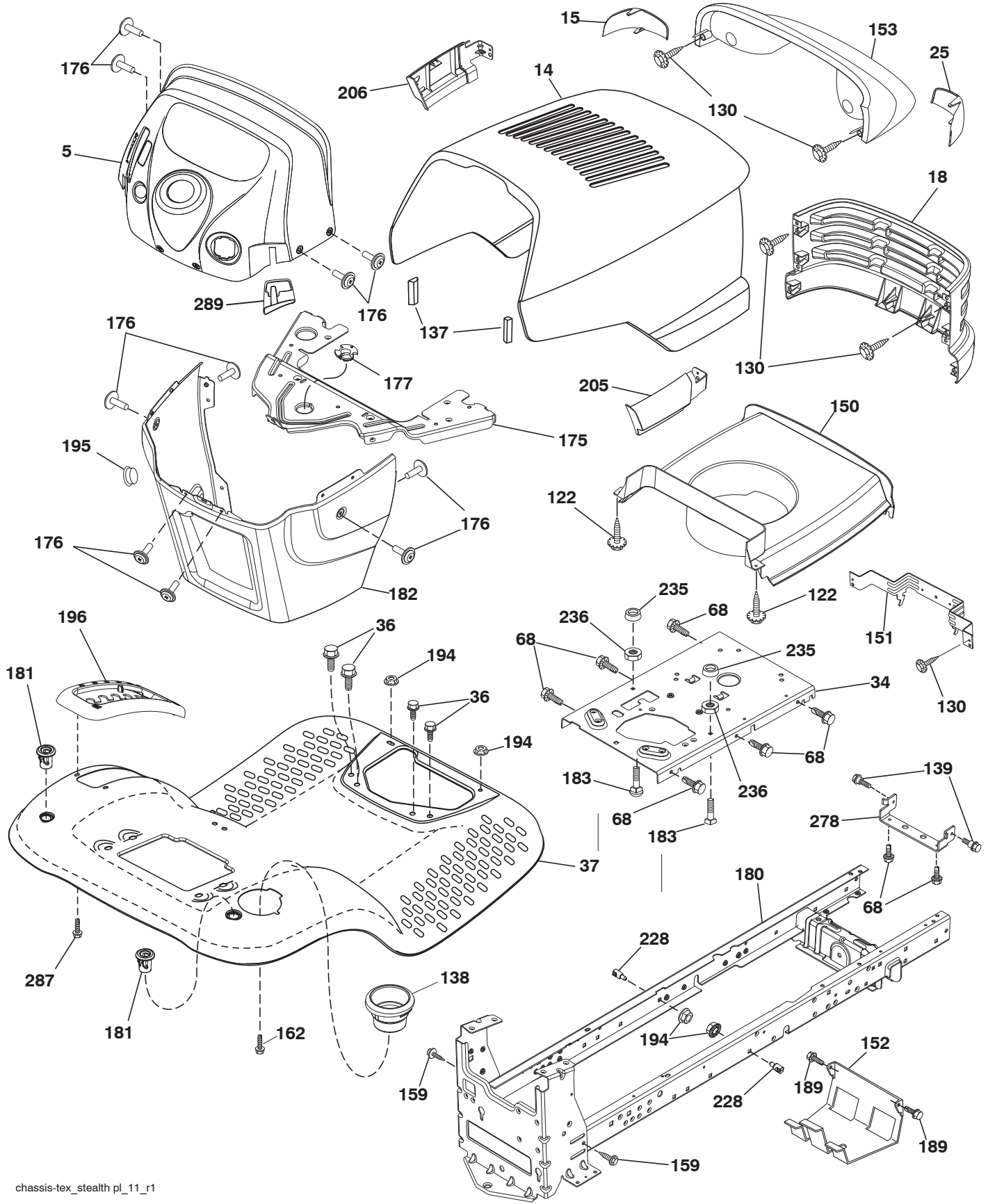

chassis-tex_stealth_pl_11_r1

**TRACTOR - MODEL NO. 936053 (96046002602), PRODUCT NO. 960 46 00-26
CHASSIS**

ITEM NO.	MFG. NO.	ARIENS PART NO.	DESCRIPTION
5	532 44 11-25	21547736	DASH P/L TEX CABLE
14	532 44 18-22	21547739	HOOD
15	532 16 18-41	21547543	LENS ELITE ARIENS BLACK
18	532 18 71-14	21547551	GRILLE ELITE ARIENS BLACK
25	532 16 18-42	21547544	LENS ELITE HUSQ CLEAR RH
34	532 19 61-25	21546384	PLATE.ENGINE.WELDED.CHASSIS
36	817 06 05-12	21546187	SCREW.5/16-18 X 3/4.SMGML.TAP/R
37	532 44 12-66	21547643	FENDER TLT W/CPH W/FW 422
68	817 49 05-08	21546199	SCREW.THDROL.5/16-18 X 1/2TYTT
122	532 19 25-12	21547529	SCREW TO 32 X 5/8
130	532 41 63-58	21546675	SCREW
137	532 16 46-55	21547545	BUMPER HOOD LARGE 1.75
138	532 40 97-30	21547560	CUPHOLDER TL TEX 428
139	532 17 18-73	21547301	BOLT SHOULDER 5/16-18
150	532 19 03-08	21547552	AIR DUCT ENGINE ELITE SV
151	532 17 02-00	21547546	BRACKET PIVOT LASR/ELTE/HUSQLT
152	532 19 95-35	21546501	SHIELD.BROWNING.W/TEX
153	532 43 92-58	21547530	ASM LIGHT BOX
159	817 00 06-12	21546181	SCREW.HEXWSH THDR3/8-16 X 3/4.BL
162	532 14 24-32	21546106	SCREW.HEX.WSH.HI-LO.1/4X1/2 UNC
175	532 19 32-36	21547554	CROSSMEMBER LT
176	532 40 07-76	21546562	SCREW.#10-24 X 5/8.RND.QUDRX.GIM
177	532 19 52-27	21546356	BUSHING.STEERING.YT/GT
180	532 19 54-57	21547555	CHASS. WLDMT TL 12 GA/2PC 18/22
181	532 40 47-96	21547557	BUSHING MNT FEND CRGO BLK TEX
182	532 19 25-51	21547553	DASH LOWER LT CCS
183	874 52 05-20	21547383	BOLT.FIN.HEX.5/16-18 UNC X1-1/4
189	817 00 05-12	21546180	SCREW.5/16-18X3/4.SMGML.TAP/BL
194	873 90 05-00	21546789	NUT, LOCK HEX FLANGE 5/16-18 UNC
195	532 40 41-37	21547532	PLUG HOLE DASH LOWER
196	532 43 95-30	21547812	CONSOLE ASM.DECKLFT.BL/RBT.TLT
205	532 18 71-11	21547549	SKIRT SIDE RH ELITE HUSQ 428
206	532 18 71-12	21547550	SKIRT SIDE LH ELITE HUSQ 428
228	532 19 51-61	21546343	STUD.FASTNER.W/D'ANTI-ROTATIO
235	532 40 61-29	21546619	SPACER.FENDER
236	873 93 05-00	21546793	NUT.CENTER LOCK.5/16-18 UNC
278	532 19 63-94	21547317	BRACKET.HOOD
287	817 60 04-06	21546204	SCREW.HEX.WASHEAD.1/4-20 X 3/8
289	532 41 14-11	21547533	PLUG CRUISE CONTROL
--	532 41 17-08	21547534	PLUG DASH

NOTE: All component dimensions given in U.S. inches
1 inch = 25.4 mm

TRACTOR - MODEL NO. 936053 (96046002602), PRODUCT NO. 960 46 00-26
DRIVE

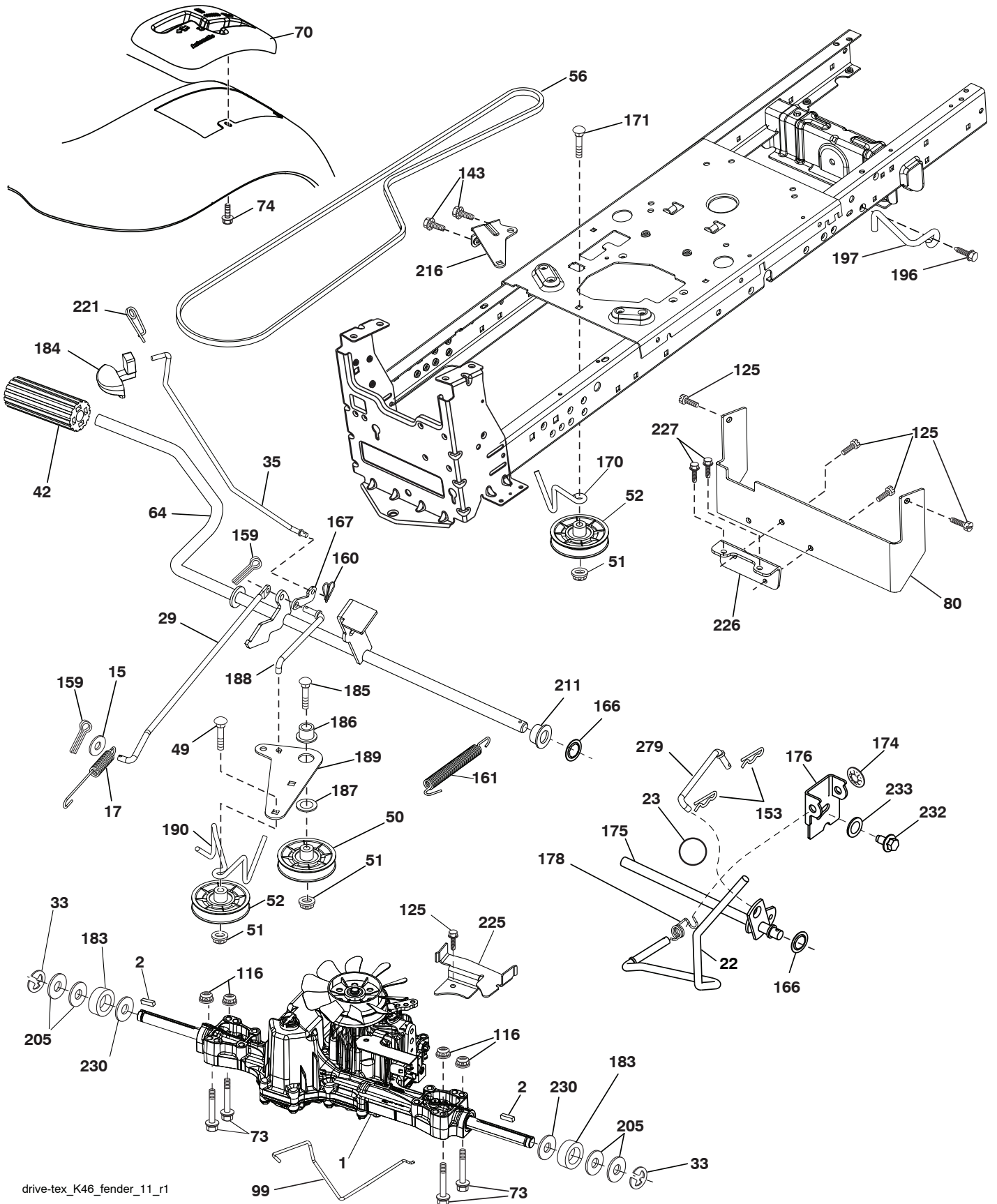

drive-tex_K46_fender_11_r1

**TRACTOR - MODEL NO. 936053 (96046002602), PRODUCT NO. 960 46 00-26
DRIVE**

ITEM NO.	MFG. NO.	ARIENS PART NO.	DESCRIPTION
1	-----	-----	TRANSAXLE, TUFFTORQ K46BA (408214) (ORDER PARTS FROM TRANSAXLE MANUFACTURER)
2	532 12 35-83	21546070	KEY.SQUARE.2.0 X .1845/.1865
15	819 13 13-16	21546284	WASHER.13/32 X 13/16 X 16 GA.
17	532 41 36-78	21546654	SPRING.BRAKE.K46.GREEN
22	532 19 76-60	21546450	ROD.SHIFT.FENDER.TLT.2006
23	532 14 08-45	21546844	KNOB DELUXE 1/2-13 UNC
29	532 40 38-06	21546593	ROD.BRAKE.K46
33	812 00 00-01	21546051	E-RING.#5133-75
35	532 19 72-75	21547556	ROD BRAKE PARKING LT TEX
42	532 12 48-72	21547538	COVER PEDAL BLK ROUND
49	872 11 06-14	21546766	BOLT.RDHD.3/8-16 UNC X 1-3/4.GR5
50	532 19 43-27	21546331	IDLER.FLAT.910"OFFSET
51	873 90 06-00	21546790	NUT, HEX, FLANGELOCK 3/8-16
52	532 19 43-26	21546330	IDLER.V-GROOVE.910"OFFSET
56	532 13 09-69	21546080	V-BELT.MOWER.92.40.42/K46
64	532 19 62-00	21546387	SHAFT ASM.PEDAL.BRAKE CONTROL
70	532 41 13-29	21547563	CONSOLE SHIFT STL HYD BLACK TX
73	874 49 05-44	21546798	BOLT HEX FLGHD 5/16-18 GR.5
74	532 14 24-32	21546106	SCREW.HEX.WSH.HI-LO.1/4X1/2UNC
80	532 44 06-19	21547733	STRAP.TORQUE.K46/18"TEX
99	532 41 57-42	21546674	ROD.SPRING.BYPASS.K46.LT.Z
116	873 90 05-00	21546789	NUT, LOCK HEX FLANGE 5/16-18 UNC
125	817 00 05-12	21546180	SCREW.5/16-18 X 3/4.SMGML.TAP/BL
143	817 49 05-08	21546199	SCREW.THDROL.5/16-18 X 1/2TYTT
153	532 12 47-88	21547536	RETAINER SPRING
159	876 02 04-12	21546820	PIN.COTTER.1/8 X 3/4.CAD.
160	532 16 94-84	21546178	RETAINER.CLIP(M).DIA.290
161	532 10 57-09	21546028	SPRING.RETURN.CLUTCH.6.75
166	532 42 91-64	21547349	NUT PUSH .625
167	532 40 52-57	21546608	LATCH.BRAKE.PARKING
170	532 19 43-22	21547311	KEEPER BELT CENTERSPAN
171	872 11 06-16	21546767	SCREW 3/8-16 UNC X 2
174	532 19 72-89	21546431	NUT.PUSH..500
175	532 40 62-08	21547558	SHAFT ASM SHIFT
176	532 19 62-14	21546394	ARM.CLEVIS.ROD.SHIFT
178	532 19 74-56	21546445	SPRING.SHIFT.GT.2006
183	532 13 70-57	21546087	SPACER.AXLE.HYDRO/PEERLES
184	532 44 16-36	21547738	HANDLE PARKING BRAKE LT TEX
185	872 11 06-22	21546768	BOLT.RDHD.3/8-16 UNC X 2-3/4 GR5
186	532 19 43-21	21546328	SPACER.RETAINER
187	819 13 32-10	21546287	WASHER.13/32 X 2 X 10 GA.
188	532 19 43-23	21546329	LINK.CLUTCH.GROUND DRIVE
189	532 19 43-17	21546324	BELLCRANK.GROUNDRIE.NSTG/NSTL
190	532 19 43-18	21546325	KEEPER.BELLCRANK.DRIVE.GROUND
196	817 00 06-16	21546182	SCREW 3/8-16 X 1
197	532 19 58-04	21546374	LINK CLUTCH ANTI-ROTATION
205	532 12 17-48	21546066	WASHER.25/32 X 1-5/8 X 16 GA.
211	532 19 62-12	21546393	BUSHING.SHAFT.BRAKE.HAND CONTR
216	532 19 61-31	21546385	BRACKET.PULLEY.IDLER.WTEX
221	532 40 31-87	21546588	RETAINER.SPRING.CLIP.HANDLE
225	532 40 33-19	21546589	KEEPER.BELT.TRANSAXLE.K46
226	532 40 15-64	21546575	BRACKET.MOUNT.TORQUE.K46.TLT
227	817 49 05-12	21547613	SCREW THDROL 5/16-18 X 3/4
230	532 18 89-67	21546272	WASHER.HARDEN..793 X 1.637 X 060
232	874 78 07-16	21546818	BOLT.FIN HEX.7/16-14X1 GR5
233	532 40 52-96	21546609	WASHER.SERRATED
279	532 40 62-07	21547580	LINK SHIFT T/A

NOTE: All component dimensions given in U.S. inches
1 inch = 25.4 mm

TRACTOR - MODEL NO. 936053 (96046002602), PRODUCT NO. 960 46 00-26
ENGINE

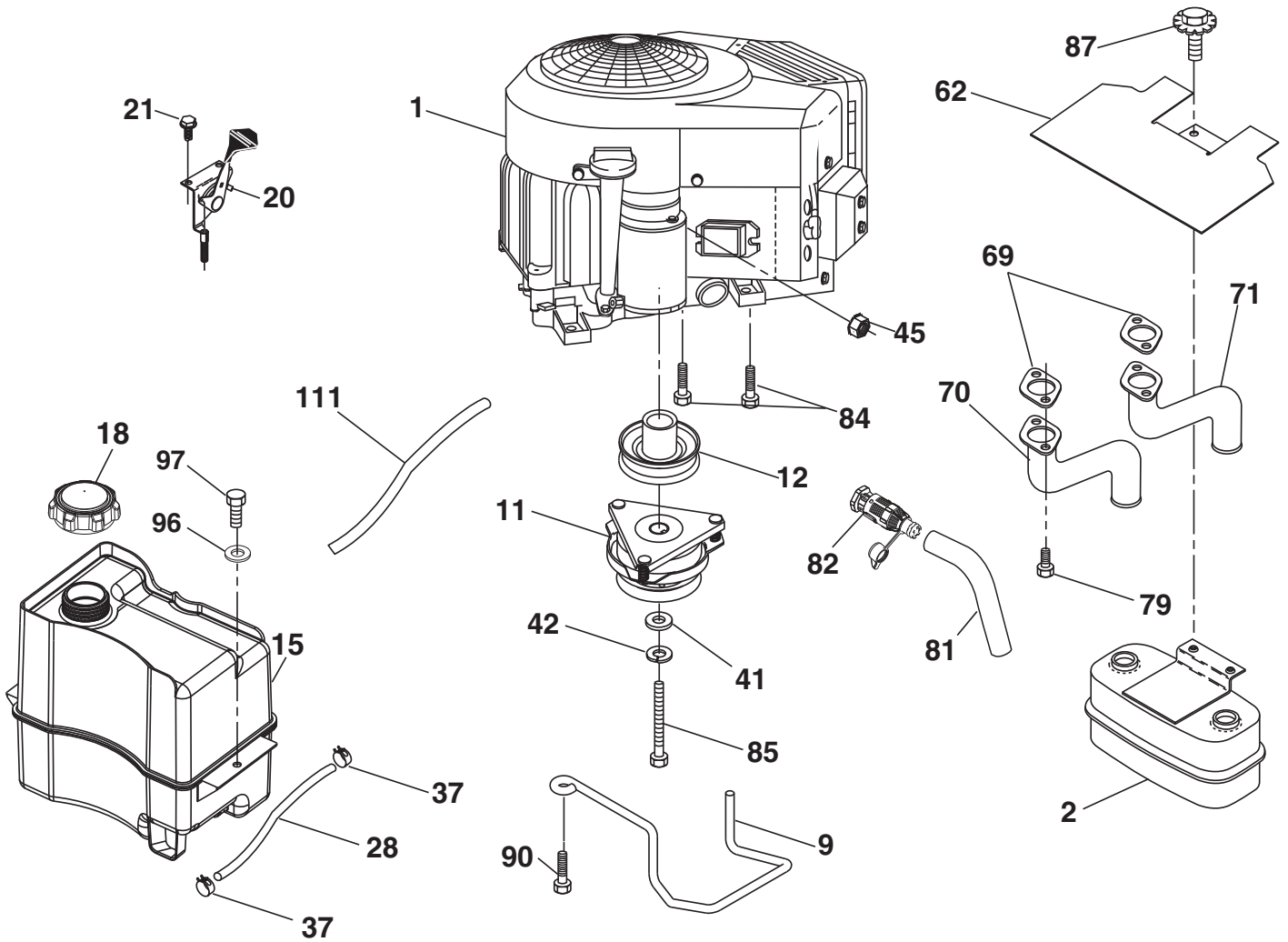

29

SPARK ARRESTER KIT

engine-tex_bs-2cyl_75

TRACTOR - MODEL NO. 936053 (96046002602), PRODUCT NO. 960 46 00-26 ENGINE

ITEM NO.	MFG. NO.	ARIENS PART NO.	DESCRIPTION
1	-----	-----	ENGINE BRIGGS MODEL NO. 407777-1580-G1 (442256) (ORDER PARTS FROM ENGINE MANUFACTURER)
2	532 14 97-23	21546118	MUFFLER ASM.TWIN.LO-TONE
9	532 19 43-20	21546327	KEEPER.BELT.ENGINE.4.25"NSTG
11	532 40 00-08	21546552	CLUTCH.ELECTRIC.LT.1"CRANK
12	532 40 50-97	21546604	PULLEY.ENGINE.TUFFTORQE.1"CRK.
15	532 43 30-07	21547650	TANK FUEL SIDE FILL 3.00 GA.
18	532 43 85-96	21547651	CAP FUEL
20	532 42 35-02	21547806	CONTROL THROTTLE/CHOKE
21	532 41 63-58	21546675	SCREW
28	532 40 11-37	21546571	LINE.FUEL.22"FRONT.EMIS.CA.LP
29	532 13 71-80	21546090	KIT.SPARK ARRESTOR (392390 B&S)
37	532 12 34-87	21546069	CLAMP.HOSE.BLK.
41	532 12 61-97	21546077	WASHER.1-1/2 ODX15/32 IDX.250
42	810 04 07-00	21546004	WASHER.LOCK.HVY HLCL.SPR.7/16
45	873 51 04-00	21546779	NUT, KEPS HEX 1/4-20 UNC
62	532 43 40-17	21547370	SHIELD.HEAT.MUFFLER.
69	532 16 53-91	21547297	GASKET MUFFLER
70	581 88 11-01	21548498	EXHAUST TUBE LH
71	581 88 10-01	21548499	EXHAUST TUBE RH
79	532 18 39-06	21547307	SCREW SOCKET HEAD 5/16-18 X 1
81	532 14 84-56	21546117	TUBE.DRAIN.OIL.EASY
82	532 42 82-87	21547348	VALVE OIL DRAIN
84	817 06 06-20	21547225	SCREW 3/8-16 X 1-1/4
85	532 17 39-37	21546191	BOLT.HEX.7/16-20 X 4 X GR. 5-1.5THR.
87	532 19 82-39	21547321	BOLT.5/16-18 UNC X 1 W/SEMS.BLK
90	817 00 06-16	21546182	SCREW.3/8-16X1.SMGML.TAP/R.BLK
96	819 09 14-16	21546277	WASHER 9/32 X 7/8 X 16 GA
97	817 67 04-12	21546207	SCREW HEXWSH THDROL 1/4-20 X 3/4
111	532 41 41-19	21547652	PURGE.LINE.CARB 3/16

NOTE: All component dimensions given in U.S. inches
1 inch = 25.4 mm

For engine service and replacement parts, call the toll free number for your engine manufacturer listed below:

Briggs & Stratton 1-800-233-3723

Engine Power Rating Information

The gross power rating for individual gas engine models is labeled in accordance with SAE (Society of Automotive Engineers) code J1940 (Small Engine Power & Torque Rating Procedure), and rating performance has been obtained and corrected in accordance with SAE J1995 (Revision 2002-05). Torque values are derived at 3060 RPM; horsepower values are derived at 3600 RPM. Actual gross engine power will be lower and is affected by, among other things, ambient operating conditions and engine-to-engine variability. Given both the wide array of products on which engines are placed and the variety of environmental issues applicable to operating the equipment, the gas engine will not develop the rated gross power when used in a given piece of power equipment (actual "on-site" or net power). This difference is due to a variety of factors including, but not limited to, accessories (air cleaner, exhaust, charging, cooling, carburetor, fuel pump, etc.), application limitations, ambient operating conditions (temperature, humidity, altitude), and engine-to-engine variability. Due to manufacturing and capacity limitations, Briggs & Stratton may substitute an engine of higher rated power for this Series engine.

TRACTOR - MODEL NO. 936053 (96046002602), PRODUCT NO. 960 46 00-26
STEERING ASSEMBLY

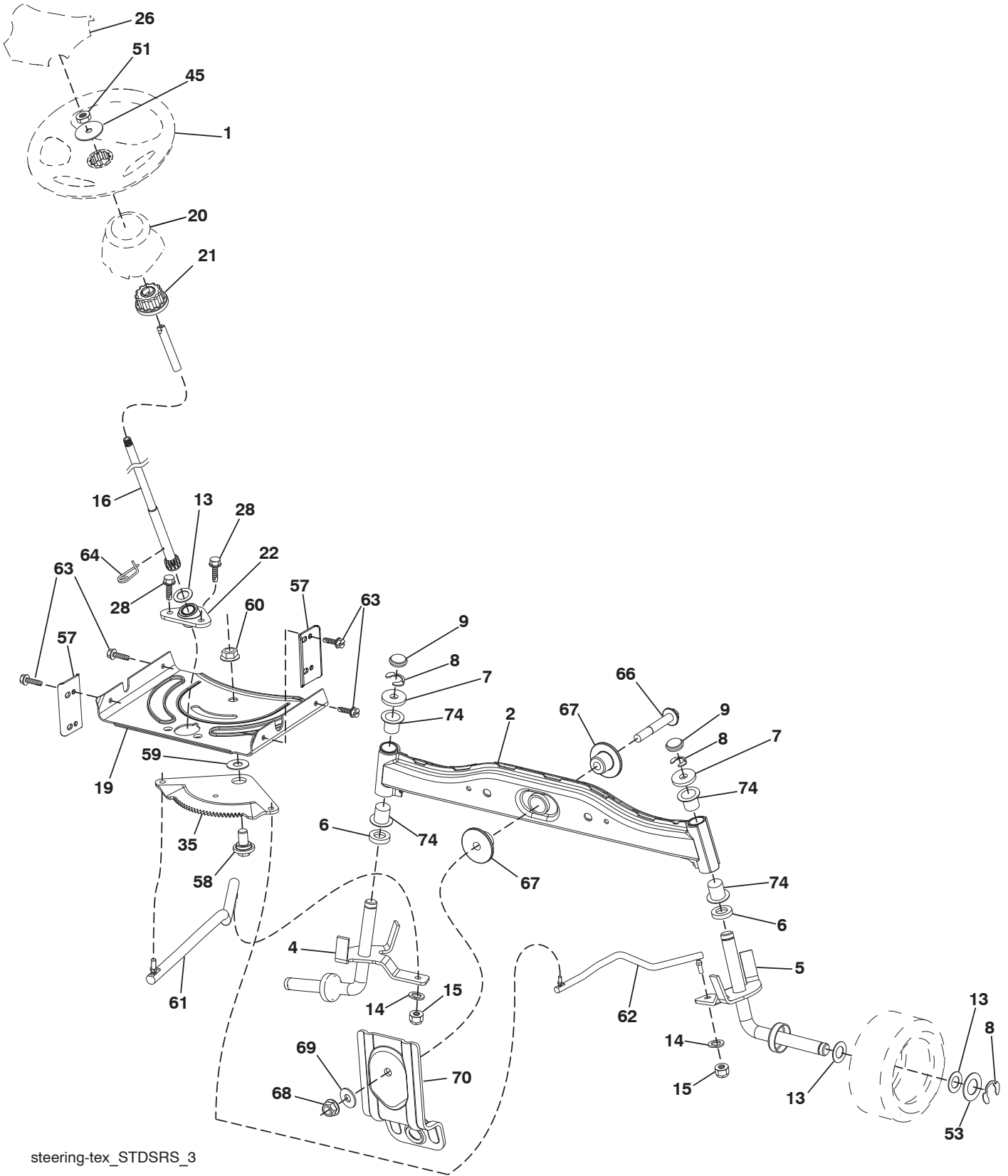

steering-tex_STDSRS_3

**TRACTOR - MODEL NO. 936053 (96046002602), PRODUCT NO. 960 46 00-26
STEERING ASSEMBLY**

ITEM NO.	MFG. NO.	ARIENS PART NO.	DESCRIPTION
1	532 19 46-37	21547835	WHEEL STEERING
2	532 41 81-68	21546681	AXLE ASM.WELDED
4	532 40 30-87	21546582	SPINDLE.WELDED.LH.15"TEX
5	532 40 30-88	21546583	SPINDLE.WELDED.RH.15"TEX
6	532 12 49-31	21547540	WASHER THRUST .75 X 1.230
7	532 12 17-48	21546066	WASHER.25/32 X 1 1/8 X 16GA.
8	812 00 00-29	21546053	RING.KLIP.#T5304-75
9	532 12 12-32	21546064	CAP.SPINDLE.FR.TOP.BLK.
13	532 12 17-49	21546067	WASHER.25/32 X 1 1/4 X 16 GA.
14	810 04 06-00	21546003	WASHER, LOCK 3/8
15	873 54 06-00	21546782	NUT.CROWNLOCK.3/8-24
16	532 40 82-19	21546628	SHAFT.STEER.3/4 TEX.NON-PLATED
19	532 19 47-29	21546334	PLATE.STEER.DDL.NLT/NGT
20	532 41 14-25	21547564	BOOT STEERING LT TEX P/L .428
21	532 18 67-37	21546234	ADAPTER.WHEEL.STRG..760
22	532 42 05-37	21547007	STEERING SUPT. LOWER
26	532 19 46-03	21547836	CAP WHEEL STEERING BLACK
28	817 00 06-12	21546181	SCREW.HEXWSH THDR 3/8-16 X 3/4.BL
35	532 19 47-32	21546335	GEAR SECTOR.PLATE.DDL.NLT/NGT
45	819 11 38-12	21546280	WASHER.11/32ID X2 3/8OD X 12GA
51	873 94 08-00	21546795	NUT.HEX.JAM.TOPLOCK.1/2-20 UNF
53	532 18 89-67	21546272	WASHER.HARDEN..793 X 1.637 X 060
57	532 40 74-65	21546623	BRACKET.UPSTOP.TEX
58	532 19 47-47	21546339	BOLT.SHOULDER.SECTOR.PIVOT.CFM
59	532 19 47-48	21546340	WASHER.THRUST.SECTOR.STEER.NLT
60	873 97 10-00	21546797	NUT.FLANGE LOCK.5/8-11
61	532 19 47-40	21546337	DRAGLINK.LH.BALLSTUD.DDL.
62	532 19 47-41	21546338	DRAGLINK.RH.BALLSTUD.DDL
63	817 00 05-12	21546180	SCREW.5/16-18X3/4.SMGML.TAP/BL
64	532 19 98-49	21546512	RETAINER.CLIP.SPRING.STEERING
66	871 02 07-48	21546754	BOLT.HEX.FGHD.7/16-14 X 3.SERR
67	532 19 47-37	21546336	BUSHING.PM.FRONT AXLE
68	873 90 07-00	21546791	NUT.LOCK.FLANGE.7/16-14.GR5
69	532 19 91-62	21546483	WASHER.1.5 X .505 X .118
70	532 19 61-97	21546386	BRACKET.DECK.SUSPENSION.FRONT
74	532 12 49-37	21547541	BEARING COL STRNG BLK

NOTE: All component dimensions given in U.S. inches
1 inch = 25.4 mm

TRACTOR - MODEL NO. 936053 (96046002602), PRODUCT NO. 960 46 00-26
MOWER DECK

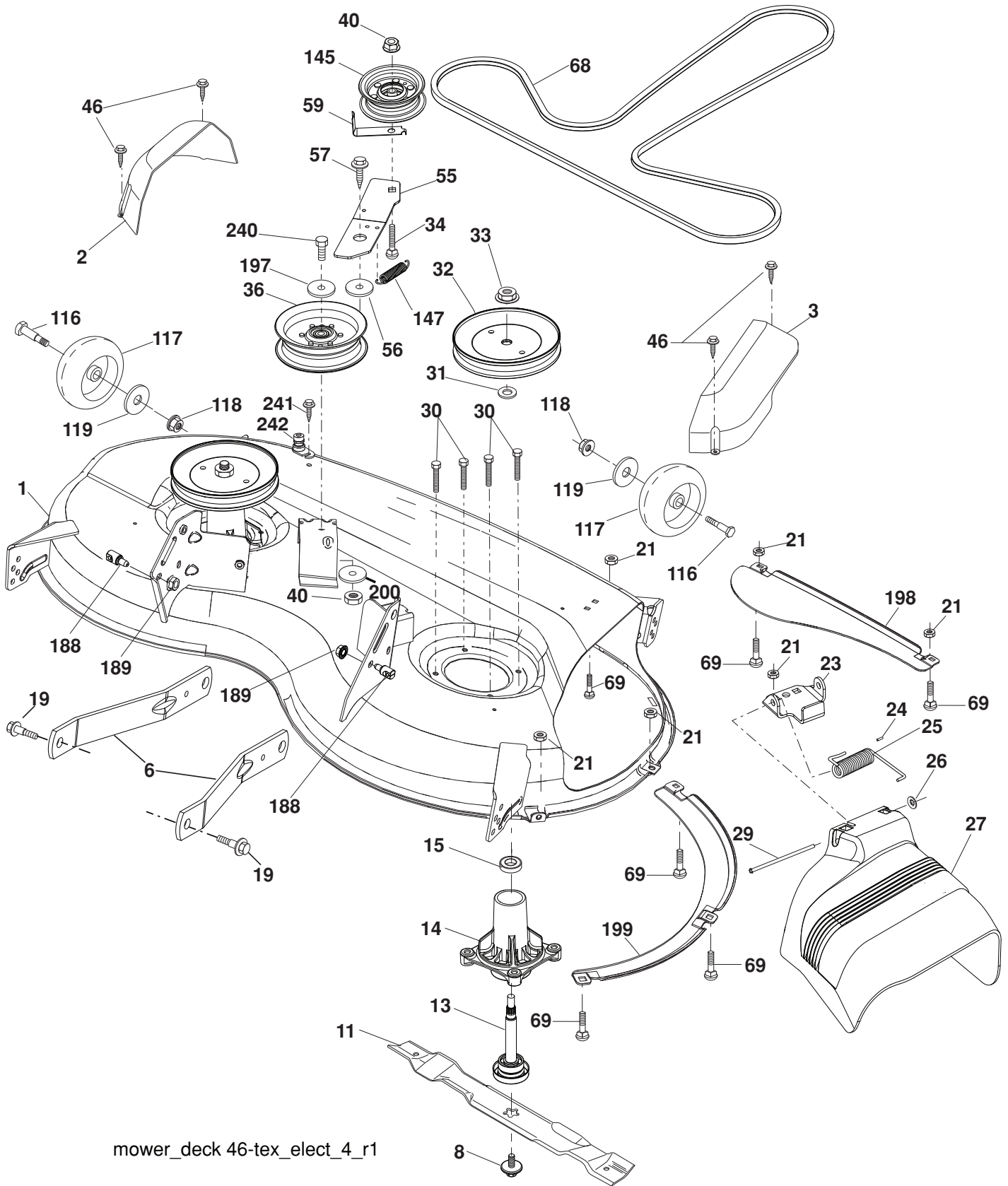

mower_deck 46-tex_elect_4_r1

**TRACTOR - MODEL NO. 936053 (96046002602), PRODUCT NO. 960 46 00-26
MOWER DECK**

ITEM NO.	MFG. NO.	ARIENS PART NO.	DESCRIPTION
1	532 44 23-75	21547821	MOWER HOUSING
2	532 40 55-07	21546618	COVER.MANDREL LH
3	532 40 55-06	21546617	COVER.MANDREL RH
6	532 19 51-86	21546347	ARM.SUSPENSION.MOWER.REAR.LD
8	532 19 30-03	21546301	BOLT/WASHER ASM.7/16-20.UNF
11	532 40 53-80	21546611	BLADE.MOWER.46"HI LIFT BAGGER
13	532 19 28-72	21546300	SHAFT ASM.MNDRL.N/GREASEABLE
14	532 18 72-81	21546238	HOUSING.MANDREL.4PT.SERVICE
15	532 11 04-85	21546046	BEARING.BALL.MANDREL
19	532 19 65-39	21546411	BOLT.SHOULDER
21	873 68 05-00	21546784	NUT, HEX, CROWNLOCK 5/16-18
23	532 19 25-57	21546296	BRACKET.DEFLECTOR.38/42"2005
24	532 10 53-04	21546025	CAP.SLEEVE.80 X.112.BLK.MOWER
25	532 19 70-26	21546416	SPRING.TORSION.DFL.38/42/46.GR
26	532 11 04-52	21546045	NUT.PUSH.PHOS.& OIL
27	532 40 53-57	21546610	SHIELD.DEFLECTOR.MOWER 46"BLK
29	532 13 14-91	21546081	ROD.HINGE.42/46"
30	532 17 39-84	21546192	SCREW.THDROLL.DOD PT.HEX
31	532 18 76-90	21546253	WASHER.SPACER.MANDREL
32	532 19 74-73	21546446	PULLEY.MANDREL.5.438 PD.42"
33	532 40 02-34	21546554	NUT.FLANGE.LOCK.TOP
34	872 11 06-12	21546765	BOLT.CARR.SH.3/8-16 X 1-1/2.GR5
36	532 19 73-79	21546440	PULLEY.IDLER.4.50.RAW
40	873 90 06-00	21546790	NUT, HEX, FLANGELOCK 3/8-16
46	532 13 77-29	21546091	SCREW.THDROLL.1/4-20 X 5/8
55	532 19 72-49	21546419	IDLER.ARM
56	532 19 90-92	21546482	SPACER.RETAINER
57	817 00 06-16	21546182	SCREW.3/8-16X1.SMGML.TAP/R.BLK
59	532 14 10-43	21546103	GUARD.TUV.IDLER
68	532 40 51-43	21546607	V-BELT
69	872 14 05-05	21546179	BOLT.5/16-18 HEX.WHS.HD.LCKSERR
116	532 12 48-42	21547537	BOLT SHLD "A" 2.41 "B" 1.66
117	532 18 86-06	21546267	WHEEL.GAGE.HALF.SPOKED
118	873 90 06-00	21546790	NUT.CENTERLOCK.3/8-16 UNC
119	819 12 14-14	21546281	WASHER 3/8 X 7/8 X 14 GA.
145	532 19 31-97	21546308	PULLEY.IDLER
147	532 19 72-51	21547318	SPRING
188	532 19 51-61	21546343	STUD.FASTNER.W/D'ANTI-ROTATION
189	873 90 05-00	21546789	NUT, LOCK HEX FLANGE 5/16-18 UNC
197	819 13 13-12	21546283	WASHER.13-32 X 13/16 X 12 GA.
198	532 40 31-49	21546584	BAFFLE.CENTER FRONT
199	532 40 31-50	21546586	BAFFLE.FRONT RH
200	532 41 35-24	21546651	WASHER 13/32 X 1 X 1/2
240	874 52 06-36	21546799	BOLT 3/8-16 X 2-1/4 GR. 5
241	532 15 29-27	21547128	SCREW #10-32.5 3/8 FLANGE
242	532 41 55-98	21547345	PORT WASHOUT
--	532 41 64-05	21547347	COUPLING QUICK CONNECT
--	532 19 28-70	21546299	MANDREL ASSEMBLY (INCL- UDES HOUS- ING, SHAFT ASSEMBLY, AND BEARING ONLY - PULLEY/NUT/WASH-ER AND BLADE BOLT/WAS-HERS NOT INCLUDED)
--	532 43 45-66	21547373	REPLACEMENT MOWER, COMPLETE

NOTE: All component dimensions given in U.S. inches
1 inch = 25.4 mm

**TRACTOR - MODEL NO. 936053 (96046002602), PRODUCT NO. 960 46 00-26
MOWER LIFT**

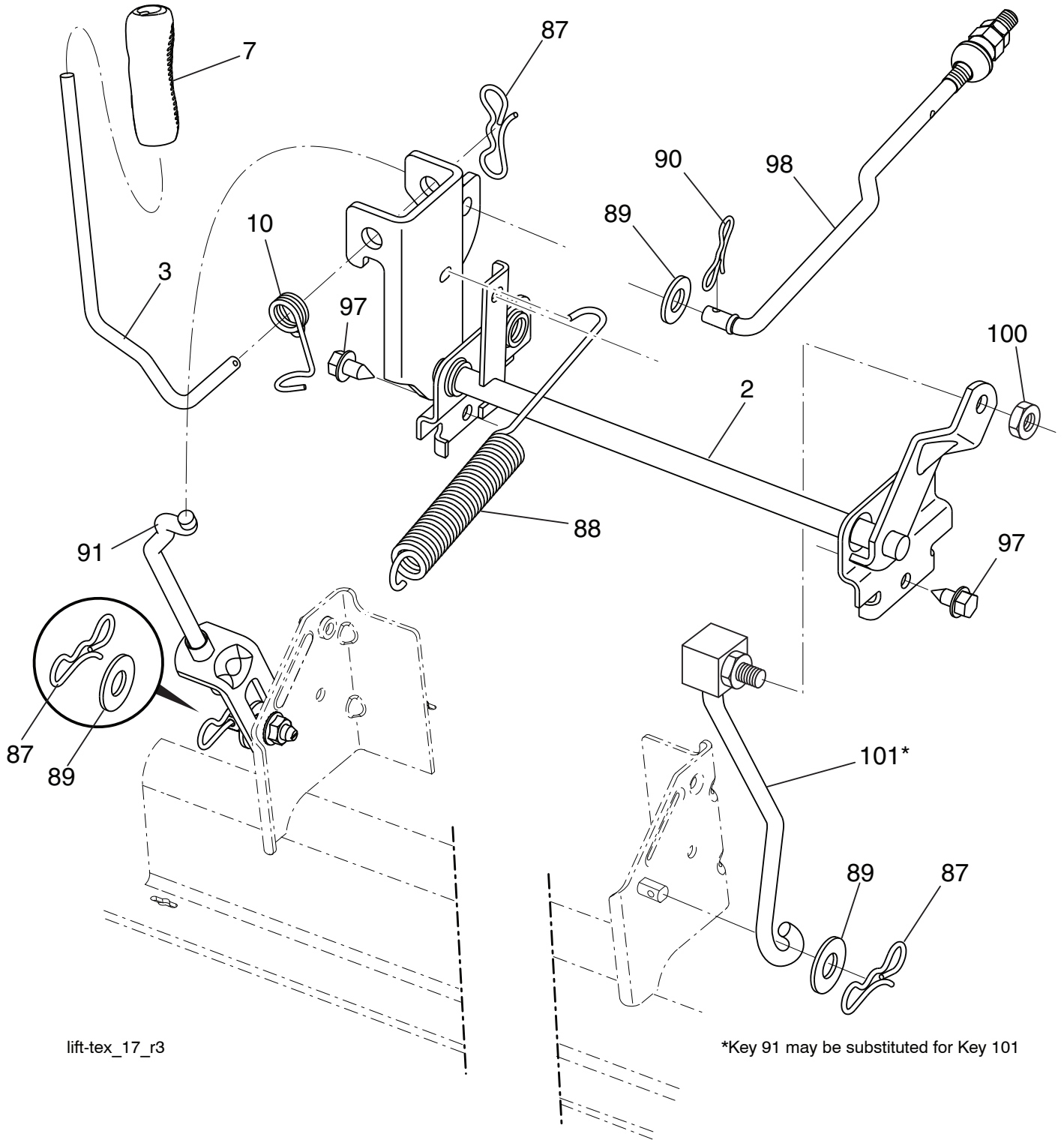

lift-tex_17_r3

*Key 91 may be substituted for Key 101

**TRACTOR - MODEL NO. 936053 (96046002602), PRODUCT NO. 960 46 00-26
MOWER LIFT**

ITEM NO.	MFG. NO.	ARIENS PART NO.	DESCRIPTION
2	532 42 20-27	21547008	SHAFT ASM., LIFT
3	532 19 52-31	21546358	LEVER.LIFT.HANDLE.LT
7	532 41 15-55	21547565	GRIP LEVER 5625 LD BLACK 428
10	532 19 63-14	21546397	SPRING.TORSION.HANDLE.LIFT
87	532 19 42-09	21546322	PIN.COTTER.7/16.BOW TIE LOCK
88	532 41 07-10	21546638	SPRING.LIFT ASSIST
89	819 19 19-12	21546292	WASHER.CLEAR ZINC
90	532 19 42-08	21546321	PIN.COTTER.5/16.BOW TIE LOCK
91	532 19 51-81	21546344	LINK ASM.LIFT.LH.REAR
97	817 00 06-12	21546181	SCREW.HEXWSH THDR3/8-16 X 3/4.BL
98	532 19 52-70	21546360	LINK ASM.SUSP.FRONT.MWR.11
100	873 93 06-00	21546794	NUT.CENTERLOCK.3/8-16 UNC
101	532 40 70-03	21546620	LINK ASM.LIFT.FIXED.38/42/46"

NOTE: All component dimensions given in U.S. inches
1 inch = 25.4 mm

TRACTOR - MODEL NO. 936053 (96046002602), PRODUCT NO. 960 46 00-26
SEAT ASSEMBLY

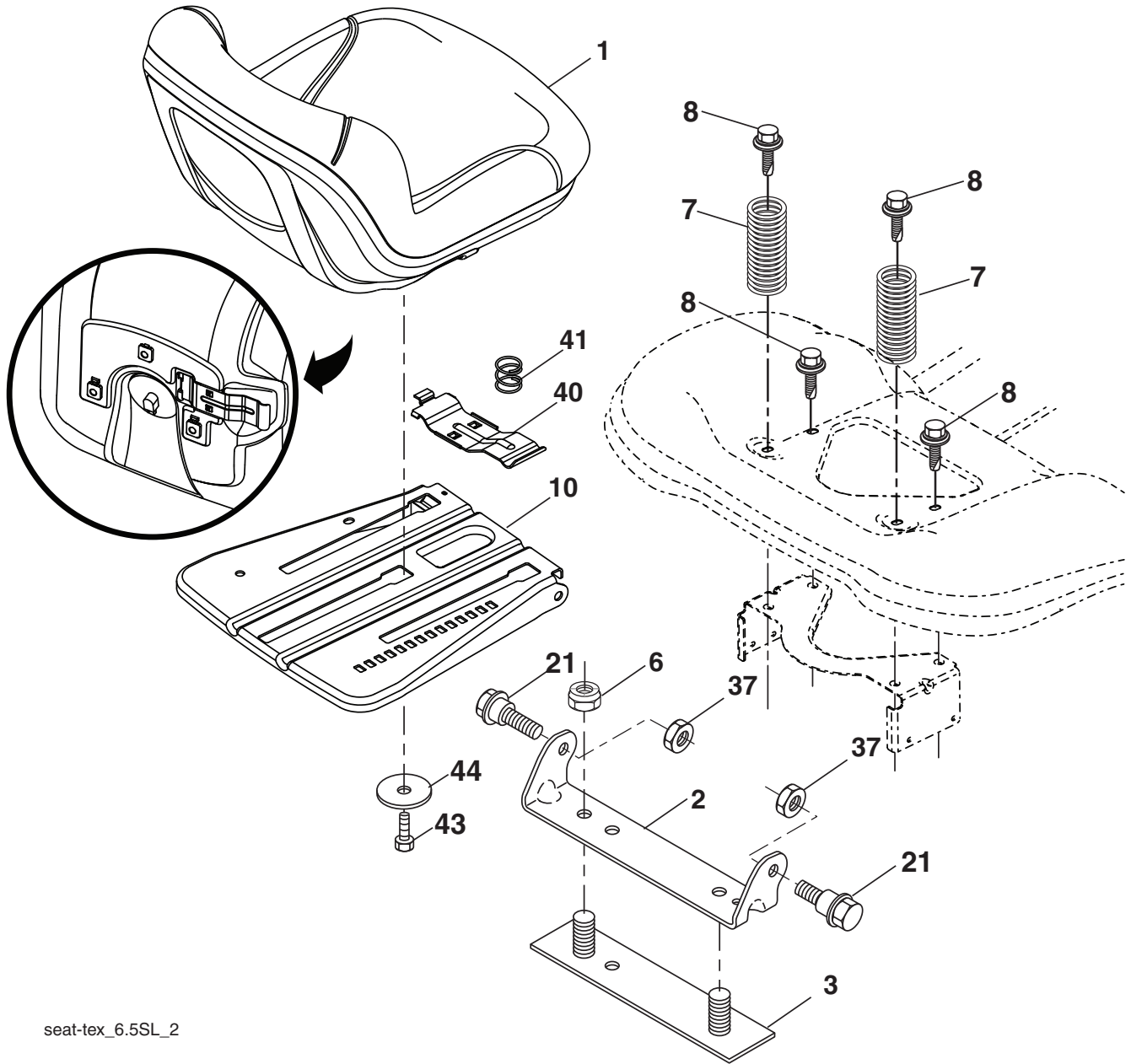

seat-tex_6.5SL_2

**TRACTOR - MODEL NO. 936053 (96046002602), PRODUCT NO. 960 46 00-26
SEAT ASSEMBLY**

ITEM NO.	MFG. NO.	ARIENS PART NO.	DESCRIPTION
1	532 42 30-10	21546703	SEAT.TA150.KB/SLD.BLK.ARIENS
2	532 18 01-66	21546216	BRACKET.PIVOT.FENDER.2002
3	532 14 06-75	21546101	STRAP ASM.FENDER.94
6	873 80 06-00	21546787	LOCKNUT, WASHER INSERT 3/8-16
7	532 12 41-81	21546074	SPRING.SEAT.CPRSN.2.250.BLK.ZI
8	532 17 18-77	21546190	BOLT.5/16-18 UNC X 3/4 W/SEMS.BLK
10	532 19 69-77	21546414	PAN ASM.SEAT.3PT.
21	532 17 18-52	21546189	BOLT.SHLD.5/16-18 UNC-2A.BLK D
37	873 80 05-00	21546786	LOCKNUT, WASHER INSERT 5/16-18
40	532 19 76-61	21546451	HANDLE.SLIDE.SEAT.TEX.MILSCO
41	532 19 82-00	21546473	SPRING.LATCH.SEAT.TEX
43	874 76 06-12	21546810	BOLT.FIN.HEX.3/8-16 UNC X 3/4
44	819 13 38-12	21546288	WASHER.13/32 X 2 3/8 X 12 GA.

NOTE: All component dimensions given in U.S. inches
1 inch = 25.4 mm

**TRACTOR - MODEL NO. 936053 (96046002602), PRODUCT NO. 960 46 00-26
DECALS**

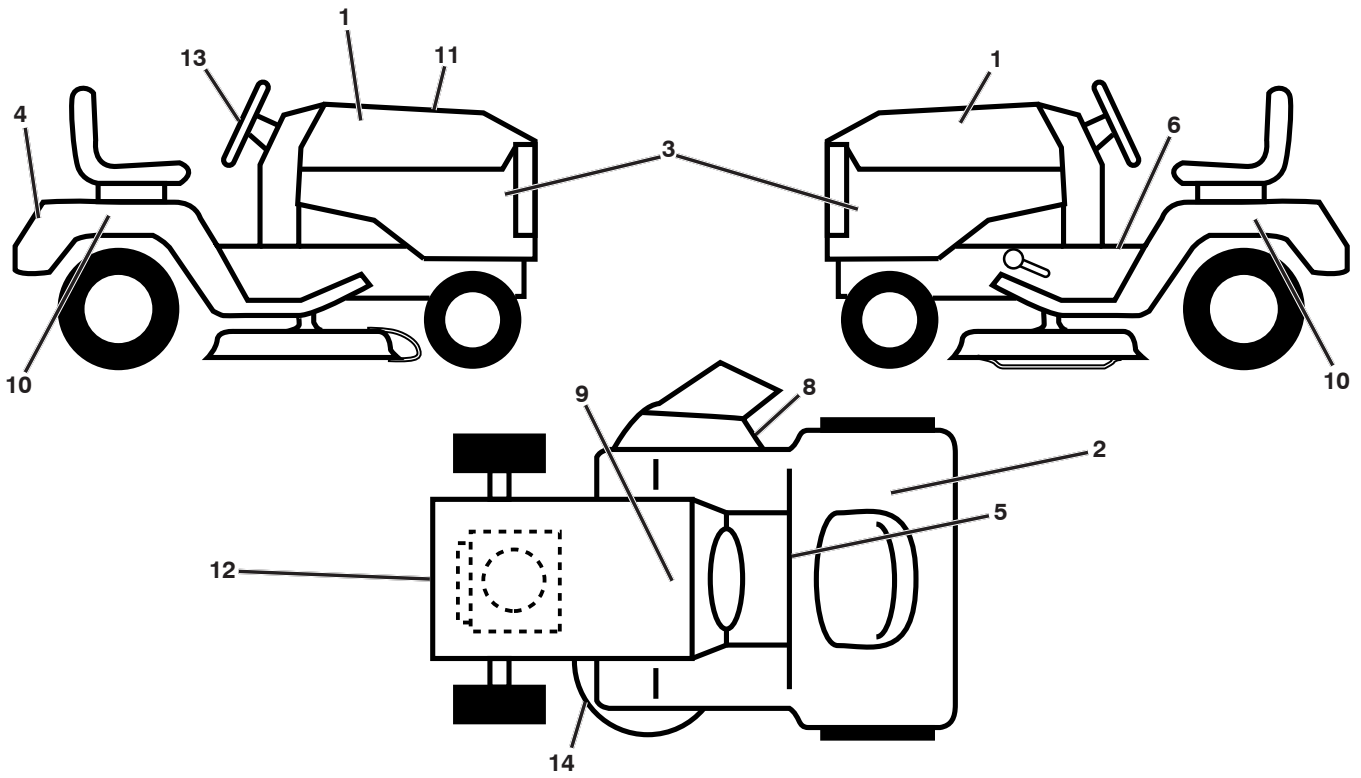

WHEELS AND TIRES

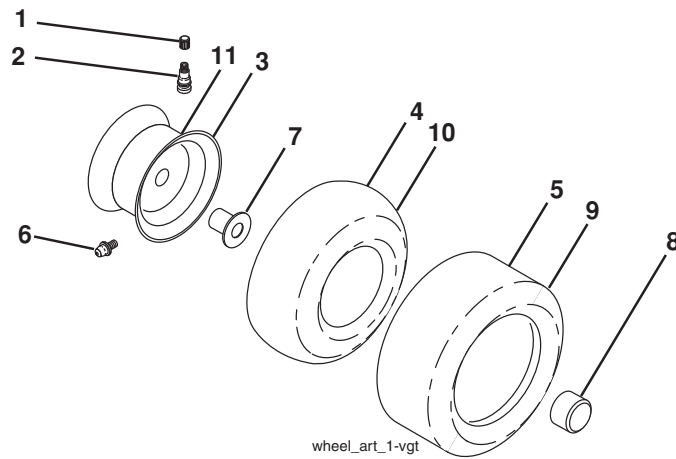

**TRACTOR - MODEL NO. 936053 (96046002602), PRODUCT NO. 960 46 00-26
DECALS**

ITEM NO.	MFG. NO.	ARIENS PART NO.	DESCRIPTION
1	532 44 15-85	21547674	DECAL HOOD RH PRECISION ARIENS
2	532 43 81-60	21547829	LABEL.EAP COMPLIANCE
3	532 44 18-81	21547819	DECAL.SDPNL.PWRDBY.ARIENS
4	532 43 91-24	21547145	DECAL.FENDER.REAR.ARIENS
5	532 44 63-54	21547918	DECAL
6	532 41 16-57	21547338	DECAL, WARNING START INST.
8	532 17 05-63	21546186	DECAL.MOWER.WARN.KEEP HAND AWY
9	532 14 50-05	21546109	DECAL.BAT.DAN/POI P/L SYM.WPN
10	532 43 93-42	21547670	DECAL FENDER SIDE HYDRO ARIENS
11	532 43 96-05	21547576	DECAL REPLACEMENT
12	532 42 95-56	21547569	DECAL ENGINE
13	532 44 26-55	21547837	DECAL.WHEEL.STEER.ARIENS
14	532 16 03-96	21546145	DECAL.V-BELT.SCH.42/46"MEC/ELE
--	532 41 12-73	21547561	PAD FOOTREST
--	532 16 69-60	21546177	DECAL.BYPASS.FENDER.CRD/LT/YT
--	532 40 95-05	21547559	PAD FOOTREST LH TLT BLACK .428
--	532 44 16-46	21547653	MANUAL, OPERATORS (ENGLISH/SPANISH)
--	532 44 30-25	21547838	MANUAL, PARTS (ENGLISH/SPANISH)

NOTE: All component dimensions given in U.S. inches
1 inch = 25.4 mm

ITEM NO.	MFG. NO.	ARIENS PART NO.	DESCRIPTION
1	532 05 91-92	21546747	CAP, VALVE, TIRE
2	532 06 51-39	21546751	STEM, VALVE
3	532 10 67-32	21547389	RIM ASM.6"FRONT.BLACK.SERVICE
4	532 05 99-04	21546748	TUBE, FRONT
5	532 10 62-22	21546034	TIRE, FRONT
6	532 12 49-57	21546037	RIM ASM.6"FRONT.BLACK.SERVICE
7	532 12 49-59	21547542	BEARING FLANGE
8	532 17 50-39	21547547	CAP AXLE (FRONT WHEEL ONLY)
9	532 13 84-68	21546094	TIRE.R.TS.20 X 8-8.C.SERVICE
10	532 12 49-26	21547539	TUBE, REAR
11	532 10 61-08	21547256	RIM ASM.8"REAR.W.GRY.SRVCE.643
--	532 14 43-34	21546845	SEALANT, TIRE (10 OZ. TUBE)

NOTE: All component dimensions given in U.S. inches
1 inch = 25.4 mm



Ariens Company
 655 West Ryan Street
 Brillion, WI 54110-1072
 1-877-257-6920
 www.ariens.com

PARTS AND SERVICE

This product has been expertly engineered and carefully manufactured to rigid quality standards. As with all mechanical products, some adjustments or part replacement may be necessary during the life of your unit.

For parts and service, contact your local Ariens dealer. To find a dealer in your area, call 1-877-257-6920, or use the Dealer Locator on our web site, www.ariens.com.

- For replacement parts, have available the following information:
 - a. Model Number/Manufacturer's I.D. Number.
 - b. Description of part.

For Technical Assistance: call 1-877-257-6920.

For a Parts Manual, go to our website: www.ariens.com/corporate/Pages/customerservice.aspx

MODEL NUMBER _____

SERIAL NUMBER _____

DATE OF PURCHASE _____

THE MODEL AND SERIAL NUMBERS WILL BE FOUND ON A DECAL ATTACHED TO THE FENDER UNDER THE SEAT OF YOUR TRACTOR.

YOU SHOULD RECORD BOTH SERIAL NUMBER AND DATE OF PURCHASE AND KEEP IN A SAFE PLACE FOR FUTURE REFERENCE.

Ariens

PRODUCT	MAINTENANCE LEVEL	SERIAL
960460026	02	120108A001234
MODEL		
936053		
46" Precision Hydro Tractor		

FOR SERVICE CALL 1-877-257-6920 CONFORMS TO ANSI B71.1-2003 SAFETY STANDARDS
 ASSEMBLED IN U.S.A. 424354
 ORANGEBURG, SC 29116



Arrens Company
 655 West Ryan Street
 Brillion, WI 54110-1072
 1-877-257-6920
 www.arrens.com

PARTES Y SERVICIO

Este producto ha sido diseñado por expertos y fabricado con cuidado según estrictas normas de calidad. Como con todos los productos mecánicos, pueden requerirse algunos ajustes o el cambio de algunas partes durante la vida útil de la unidad.

Para obtener partes y servicios, contacte a su distribuidor Arrens local. Para buscar un distribuidor en su zona, llame al 1-877-257-6920 o use el Localizador de distribuidores de nuestro sitio web, www.arrens.com.

- Para obtener repuestos, tenga preparada la siguiente información:

a. Número de modelo/Número de I.D. del fabricante

b. Descripción de la parte.

Para obtener asistencia técnica: llame al 1-877-257-6920.

Para obtener un manual de partes, visite nuestro sitio web: www.arrens.com/corporate/Pages/customer-service.aspx

NÚMERO DE MODELO _____
 NÚMERO DE SERIE _____
 FECHA DE COMPRA _____

DEBE TOMAR NOTA DEL NÚMERO DE SERIE Y DE LA FECHA DE COMPRA Y GUARDARLOS EN UN LUGAR SEGURO PARA REFERENCIA FUTURA.

Arrens®

PRODUCT	MAINTENANCE LEVEL	SERIAL
960460026	02	120108A001234
MODEL		
46" Precision Hydro Tractor		

FOR SERVICE CALL 1-877-257-6920
 ASSEMBLED IN U.S.A.
 CONFORMS TO ANSI B71.1-2003 SAFETY STANDARDS
 424354

ORANGEBURG, SC 29116

NÚMERO DE MODELO: 936053

NÚMERO DE SERIE: 120108A001234

CÓDIGO MFG.	NO.	PIEZA NO.	DESCRIPCIÓN
532 44 15-85	1	21547674	CALCOMANÍA PARA LA CAPOTA
532 43 81-60	2	21547829	ETIQUETA EAP CONFORMIDAD
532 44 18-81	3	21547819	CALCOMANÍA PARA EL PANEL LATERAL
532 43 91-24	4	21547145	CALCOMANÍA PARA EL GUARDABARROS
532 44 63-54	5	21547918	CALCOMANÍA
532 41 16-57	6	21547338	CALCOMANÍA, ADVERTENCIA
532 17 05-63	8	21546186	CALCOMANÍA, ADVERTENCIA
532 14 50-05	9	21546109	CALCOMANÍA DE PELIGRO/PUNTO DE INTERCONEXIÓN
532 43 93-42	10	21547670	CALCOMANÍA
532 43 96-05	11	21547576	CALCOMANÍA
532 42 95-56	12	21547569	CALCOMANÍA
532 44 26-55	13	21547837	CALCOMANÍA PARA EL VOLANTE DE DIRECCIÓN
532 16 03-96	14	21546145	CALCOMANÍA DEL DIAGRAMA
532 41 12-73	--	21547561	FORRO DEL APOYO PARA LOS PIES
532 16 69-60	--	21546177	CALCOMANÍA PARA LA DESVIACIÓN
532 40 95-05	--	21547559	FORRO DEL APOYO PARA LOS PIES (LI)
532 44 16-46	--	21547653	MANUAL DE DUEÑOS (INGLÉS/ESPAÑOL)
532 44 30-25	--	21547838	MANUAL DE DUEÑOS (INGLÉS/ESPAÑOL)

NOTA: Las dimensiones de todos los componentes están expresadas en pulgadas = 25,4 mm

CÓDIGO MFG.	NO.	PIEZA NO.	DESCRIPCIÓN
532 05 91-92	1	21546747	TAPA DE LA VÁLVULA DEL NEUMÁTICO
532 06 51-39	2	21546751	VÁSTAGO DE LA VÁLVULA
532 10 67-32	3	21547389	ENSAMBLE DE LAS LLANTAS DELANTERAS
532 05 99-04	4	21546748	CÁMARA DELANTERA
532 10 62-22	5	21546034	NEUMÁTICO DELANTERO
532 12 49-57	6	21546037	ACCESORIO PARA ENGRASAR
532 12 49-59	7	21547542	RODAMIENTO DE LA BRIDA
532 17 50-39	8	21547547	TAPA DEL EJE (SOLO PARA LA RUEDA DELANTERA)
532 13 84-68	9	21546094	NEUMÁTICO TRASERO 18 X 9.5-8
532 12 49-26	10	21547539	ENSAMBLE TRASERO DE LA LLANTA 8"
532 10 61-08	11	21547256	ENSAMBLE TRASERO DE LA LLANTA 8"
532 14 43-34	--	21546845	SELLADOR PARA NEUMÁTICOS (TUBO DE 10 ONZAS [283 GR])

NOTA: Las dimensiones de todos los componentes están expresadas en pulgadas = 25,4 mm

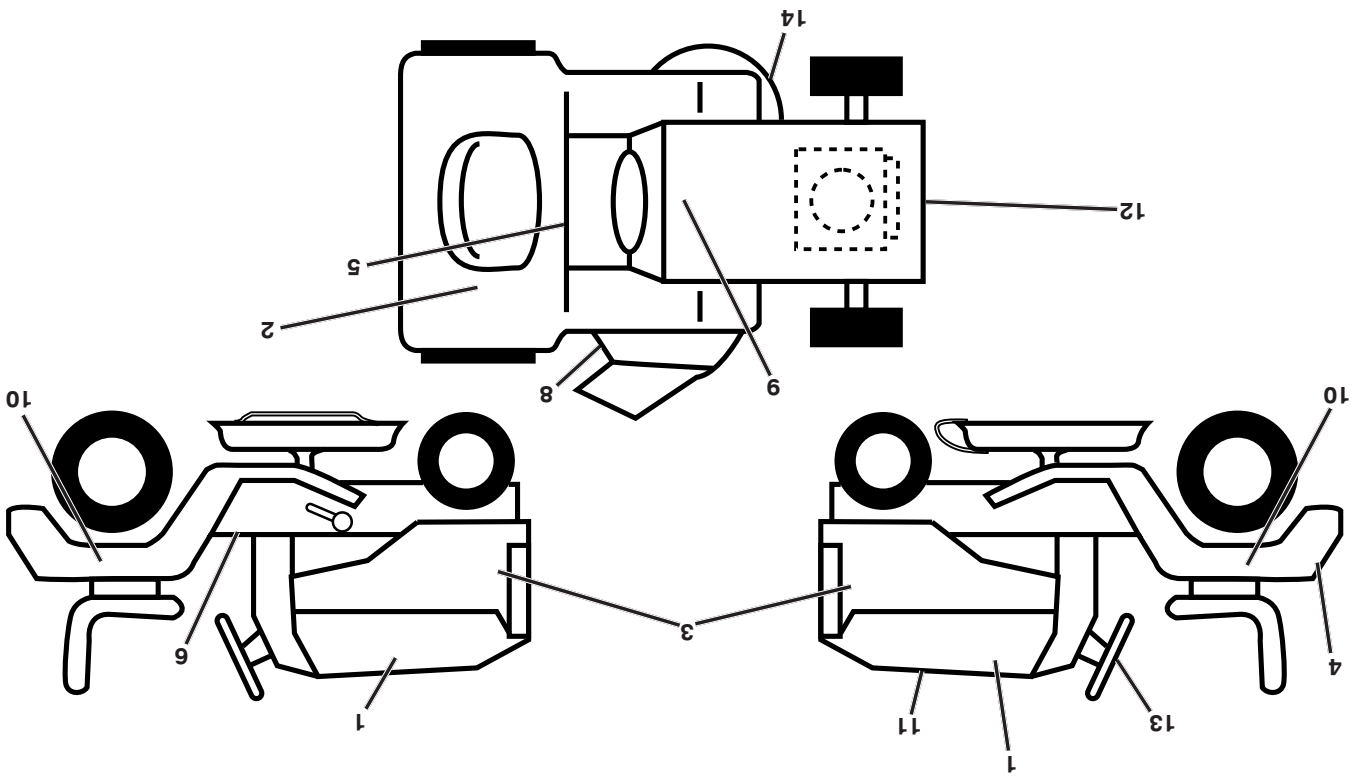

RUEDAS Y SE CANSA

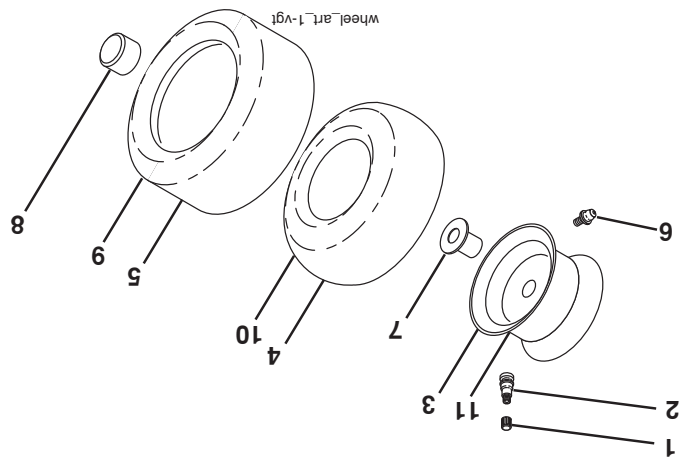

CÓDIGO MFG.	NO.	ARIENS	PIEZA NO.	DESCRIPCIÓN
532 42 30-10	1	21546703		ASIENTO
532 18 01-66	2	21546216		SOPORTE PIVOTANTE DEL GUARDABARROS
532 14 06-75	3	21546101		CONECTOR DEL ENSAMBLE DEL GUARDABARROS
873 80 06-00	6	21546787		TUERCA DE PRESIÓN C/AISLAMIENTO DE 3/8-16
532 12 41-81	7	21546074		RESORTE DEL ASIENTO
532 17 18-77	8	21546190		PERNO.5/16-18 X 3/4
532 19 69-77	10	21546414		BANDEJA DEL ASIENTO
532 17 18-52	21	21546189		PERNO 5/16-18
873 80 05-00	37	21546786		TUERCA DE PRESIÓN DE 5/16-18
532 19 76-61	40	21546451		MANIJA PARA DESLIZAR EL ASIENTO
532 19 82-00	41	21546473		RESORTE PARA TRABAR EL ASIENTO
874 76 06-12	43	21546810		PERNO DE CABEZA HEXAGONAL CON ALETA
819 13 38-12	44	21546288		ARANDELA.13/32 X 2 3/8 X 12 CALIBRE

NOTA: Las dimensiones de todos los componentes están expresadas en pulgadas = 25,4 mm

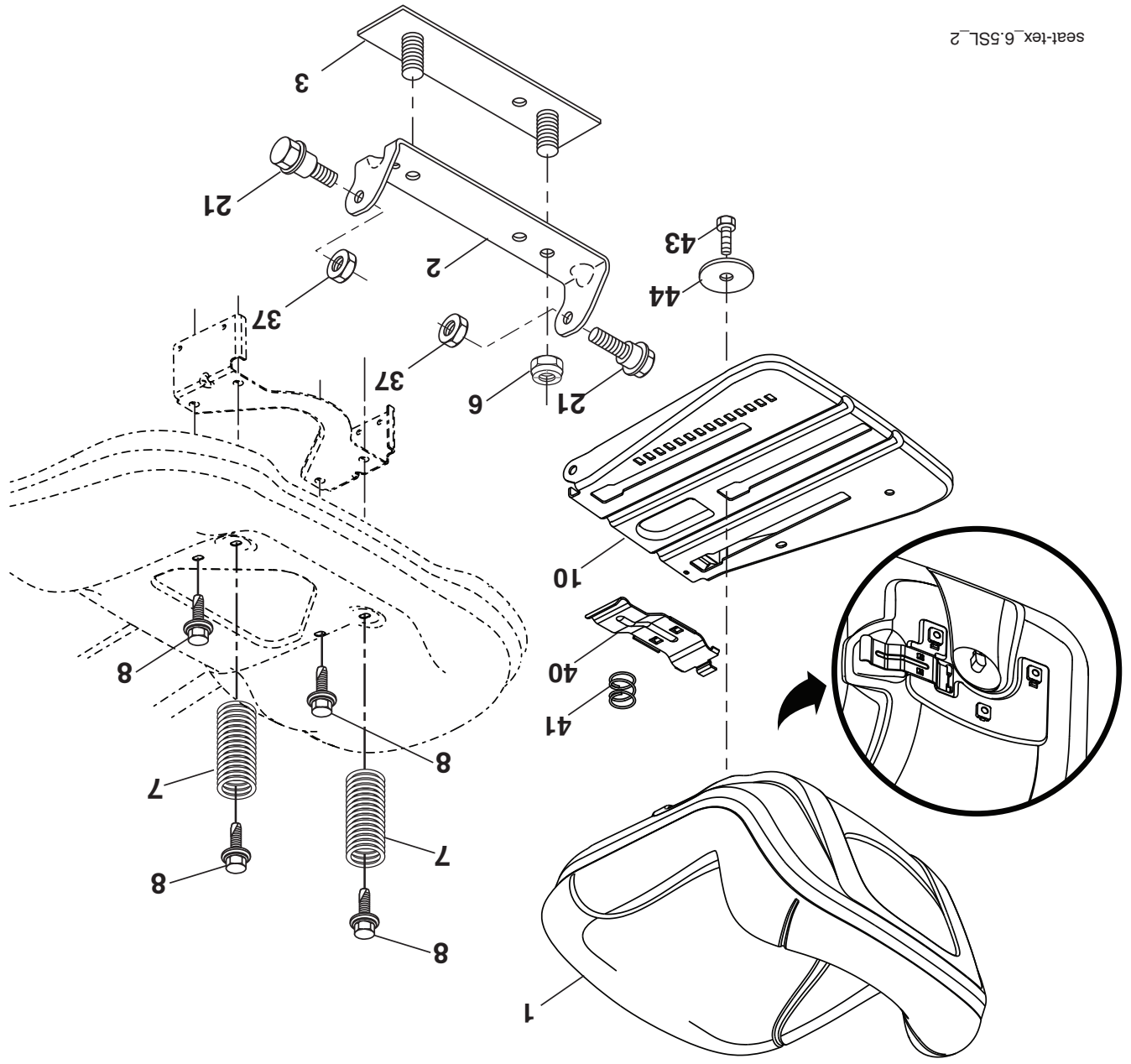

seat-tex_6.SSL_2

**TRACTOR MODELO NO. 936053 (96046002602), PRODUCTO NO. 960 46 00-26
ELEVACIÓN DE LA CORTADORA DE CÉSPED**

CÓDIGO MFG. NO.	ARIENS PIEZA NO.	DESCRIPCIÓN
2	21547008	ENSAMBLE DEL EJE DE LA ELEVACIÓN
3	532 19 52-31	ENSAMBLE DE LA PALANCA DE ELEVACIÓN
7	532 41 15-55	MANGO DE LA PALANCA
10	532 19 63-14	RESORTE DE TORSIÓN
87	532 19 42-09	PASADOR DE CHAVETA DE 7/16 CON BLOQUEO
88	532 41 07-10	EN FORMA DE MARIPOSA
89	21546638	RESORTE DE AYUDA DE LA ELEVACIÓN
89	819 19 19-12	ARANDELA DE ZINC TRANSPARENTE
90	532 19 42-08	PASADOR DE CHAVETA DE 5/16 CON BLOQUEO
91	532 19 51-81	EN FORMA DE MARIPOSA
91	21546344	ENSAMBLE DEL ACOPLAMIENTO ELEVACIÓN
97	817 00 06-12	TRASERA
97	21546181	TORNILLO DE 3/8-16 X 0,75
98	532 19 52-70	ACOPPLAMIENTO FRONTAL DE LA ELEVACIÓN
100	873 93 06-00	DE LA CORTADORA DE CÉSPED
101	532 40 70-03	TUERCA DE PRESIÓN CENTRAL DE 3/8-16 UNC
	21546620	ACOPPLAMIENTO FIJO DE LA ELEVACIÓN DE LA
		CORTADORA DE CÉSPED

NOTA: Las dimensiones de todos los componentes están expresadas en pulgadas americanas.
1 pulgada = 25,4 mm

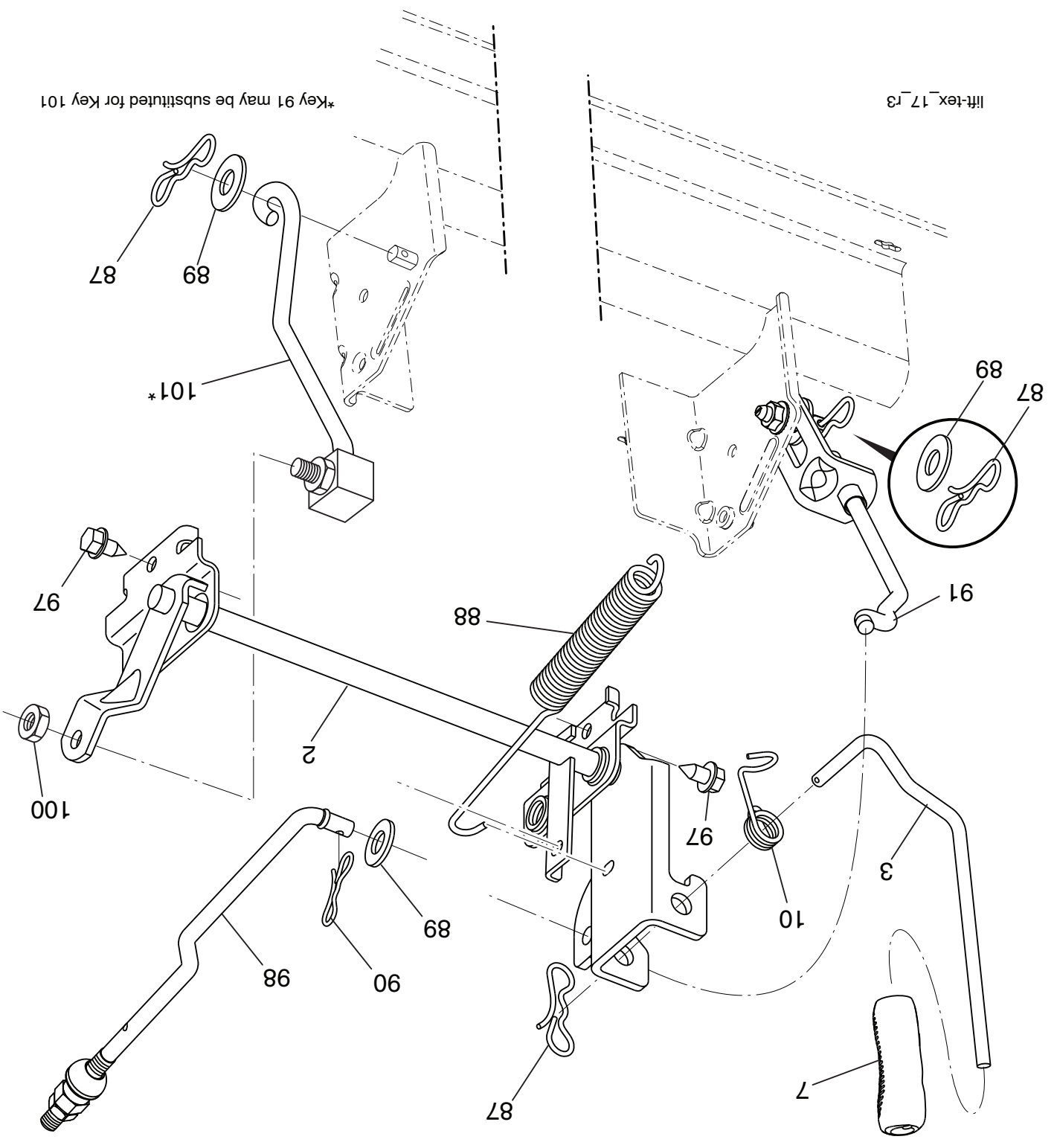

**TRACTOR MODELO NO. 936053 (96046002602), PRODUCTO NO. 960 46 00-26
PLATAFORMA DE LA CORTADORA DE CÉSPED**

CÓDIGO MFG.	NO.	NO.	DESCRIPCIÓN
		PIEZA NO.	
			ARIENS
532 44 23-75	1	21547821	CORTADORA
532 40 55-06	2	21546618	CUBIERTA DERECHA DEL MANDRIL
532 40 55-06	3	21546617	CUBIERTA IZQUIERDA DEL MANDRIL
532 19 51-86	6	21546347	BRAZO DE LA SUSPENSIÓN
532 19 30-03	8	21546301	PERNO/ARANDELA 7/16-20
532 40 53-80	11	21546611	CUCHILLA DE LA CORTADORA DE CÉSPED
532 19 28-72	13	21546300	ENSAMBLE DEL EJE DEL MANDRIL
532 18 72-81	14	21546238	CARCAZA DEL MANDRIL
532 11 04-85	15	21546046	RODAMIENTO DEL MANDRIL
532 19 65-39	19	21546411	PERNO
873 68 05-00	21	21546784	TUERCA 5/16-18
532 19 25-57	23	21546296	SOPORTE 38/42"2005
532 10 53-04	24	21546025	TAPA DE LA MANGA
532 19 70-26	25	21546416	RESORTE DE TORSIÓN DEL DEFLECTOR
532 11 04-52	26	21546045	TUERCA
532 40 53-57	27	21546610	PROTECTOR DEL DEFLECTOR
532 13 14-91	29	21546081	VARILLA DE LA BISAGRA
532 17 39-84	30	21546192	TORNILLO
532 18 76-90	31	21546253	ARANDELA
532 19 74-73	32	21546446	POLEA DEL MANDRIL
532 40 02-34	33	21546554	TUERCA
872 11 06-12	34	21546765	PERNO 3/8-16 X 1-1/2
532 19 73-79	36	21546440	POLEA LOCA
873 90 06-00	40	21546790	TUERCA, 3/8-16
532 13 77-29	46	21546091	TORNILLO.THD.ROLL.1/4-20 X 5/8
532 19 72-49	55	21546419	BRAZO DE LA POLEA
532 19 90-92	56	21546482	ESPACIADOR DE RETENCIÓN
817 00 06-16	57	21546182	TORNILLO.3/8-16X1
532 14 10-43	59	21546103	DISPOSITIVO DE PROTECCIÓN DE LA POLEA
532 40 51-43	68	21546607	CORREA TRAPEZOIDAL
872 14 05-05	69	21546179	PERNO.5/16-18
532 12 48-42	116	21547537	PERNO
532 18 86-06	117	21546267	CALIBRADOR DE LA RUEDA
873 90 06-00	118	21546790	TUERCA 3/8-16
819 12 14-14	119	21546281	ARANDELA 3/8 X 7/8 X 14 CALIBRE
532 19 31-97	145	21546308	POLEA LOCA
532 19 72-51	147	21547318	RESORTE
532 19 51-61	188	21546343	SUJETADOR DEL TRAVESANO
873 90 05-00	189	21546789	TUERCA 5/16-18
819 13 13-12	197	21546283	ARANDELA.13-32 X 13/16 X 12 CALIBRE
532 40 31-49	198	21546584	DEFLECTOR DELANTERO CENTRAL
532 40 31-50	199	21546586	DEFLECTOR DELANTERO DERECHO
532 41 35-24	200	21546651	ARANDELA 13/32 X 1 X 1/2
874 52 06-36	240	21546799	PERNO 3/8-16 X 2-1/4
532 15 29-27	241	21547128	TORNILLO #10-32.5 3/8
532 41 55-98	242	21547345	PUERTO DE LAVADO DE LA CUBIERTA
532 41 64-05	--	21547347	ACCESORIO DEL CONEXIÓN
532 19 28-70	--	21546299	ENSAMBLE DEL MANDRIL (SOLO INCLUYE LA CARCASA, EL ENSAMBLE DEL EJE Y EL RODAMIENTO; NO INCLUYE LA POLEA/ TUERCA/ARANDELA NI LOS PERNOS/ ARANDELAS DE LA CUCHILLA) REEMPLAZO DE LA CORTADORA DE CÉSPED, COMPLETA
532 43 45-66	--	21547373	COMPLETA

NOTA: Las dimensiones de todos los componentes están expresadas en pulgadas americanas.
1 pulgada = 25,4 mm

CÓDIGO MFG.	NO.	ARIENS PIEZA NO.	DESCRIPCIÓN
532	19 46-37	21547835	VOLANTE DE DIRECCIÓN
532	41 81-68	21546681	ENSAMBLE DEL EJE
532	40 30-87	21546582	ENSAMBLE DEL HUSILLO IZQUIERDO
532	40 30-88	21546583	ENSAMBLE DEL HUSILLO DERECHO
532	12 49-31	21547540	ARANDELA
532	12 17-48	21546066	ARANDELA.25/32 X 1-5/8 X 16 CALIBRE
812	00 00-29	21546053	ABRAZADERA
532	12 12-32	21546064	TAPA DEL HUSILLO
532	12 17-49	21546067	ARANDELA.25/32 X 1 1/4 X 16 CALIBRE
810	04 06-00	21546003	ARANDELA, LOCK 3/8
873	54 06-00	21546782	TUERCA.CROWNLOCK.3/8-24
532	40 82-19	21546628	EJE DE DIRECCIÓN
532	19 47-29	21546334	PLACA DE DIRECCIÓN
532	41 14-25	21547564	CUBIERTA DE LA DIRECCIÓN
532	18 67-37	21546234	ADAPTADOR DEL VOLANTE DE DIRECCIÓN
532	42 05-37	21547007	SOPORTE INFERIOR DEL VOLANTE DE DIRECCIÓN
532	19 46-03	21547836	INSERTO DEL VOLANTE DE DIRECCIÓN
817	00 06-12	21546181	TORNILLO 3/8-16 X 3/4
532	19 47-32	21546335	ENGRANAJE DEL SECTOR DE LA PLACA
819	11 38-12	21546280	ARANDELA
873	94 08-00	21546795	TUERCA 1/2-20
532	18 89-67	21546272	ARANDELA .793 X 1.637 X 060
532	40 74-65	21546623	SOPORTE
532	19 47-47	21546339	PERNO
532	19 47-48	21546340	ARANDELA
873	97 10-00	21546797	TUERCA 5/8-11
532	19 47-40	21546337	BARRA DE ACOPLAMIENTO IZQUIERDA
532	19 47-41	21546338	BARRA DE ACOPLAMIENTO DERECHA
817	00 05-12	21546180	TORNILLO.5/16-18X3/4
532	19 98-49	21546512	ABRAZADERA DE RETENCIÓN DEL
871	02 07-48	21546754	PERNO 7/16-14 X 3
532	19 47-37	21546336	BUJE
873	90 07-00	21546791	TUERCA.
532	19 91-62	21546483	ARANDELA.1.5 X .505 X .118
532	19 61-97	21546386	SOPORTE
532	12 49-37	21547541	PISTA

NOTA: Las dimensiones de todos los componentes están expresadas en pulgadas americanas.
1 pulgada = 25,4 mm

CÓDIGO MFG.	NO.	ARIENS	DESCRIPCIÓN
---	1	---	MOTOR BRIGGS MODELO NO. 407777-1580-G1 (442256) (HAGA EL PEDIDO DE LAS PIEZAS AL FABRICANTE DEL MOTOR)

532	14	21546118	SILENCIADOR
532	19	21546327	ENSAMBLE DEL SUJETADOR DE LA CORREA DEL MOTOR
532	40	21546552	POLEA DEL EMBRAGUE
532	40	21546604	POLEA DEL MOTOR
532	43	21547650	TANQUE DE COMBUSTIBLE
532	43	21547651	ENSAMBLE DE LA TAPA
532	42	21547806	CONTROL DEL REGULADOR/OBTURADOR
532	41	21546675	TORNILLO
532	40	21546571	LÍNEA DE COMBUSTIBLE
532	13	21546090	EQUIPO APAGACHISPAS
532	12	21546069	ABRAZADERA DE LA MANGUERA
532	12	21546077	ARANDELA 1-1/2 X 15/32 X .250
810	04	21546004	ARANDELA DE PRESIÓN DE 7/16
873	51	21546779	TUERCA KEPS
532	43	21547370	SILENCIADOR CON PANTALLA TÉRMICA
532	16	21547297	JUNTA DEL SILENCIADOR
581	88	21548498	TUBO DE ESCAPE IZQUIERDO
581	88	21548499	TUBO DE ESCAPE DERECHO
532	18	21547307	TORNILLO 5/16-18 X 1
532	14	21546117	TÚBO DE FÁCIL DRENAJE DE ACEITE
532	42	21547348	VÁLVULA DE ACEITE
817	06	21547225	TORNILLO 3/8-16X1-1/4
532	17	21546191	PERNO 7/16-20X4
532	19	21547321	PERNO 5/16-18
817	00	21546182	TORNILLO 3/8-16X1
819	09	21546277	ARANDELA 7/8 X 16 GA
817	67	21546207	TORNILLO 1/4-20 X 3/4
532	41	21547652	PURGUE LÍNEA 3/16

NOTA: Las dimensiones de todos los componentes están expresadas en pulgadas = 25,4 mm.
pulgadas americanas.

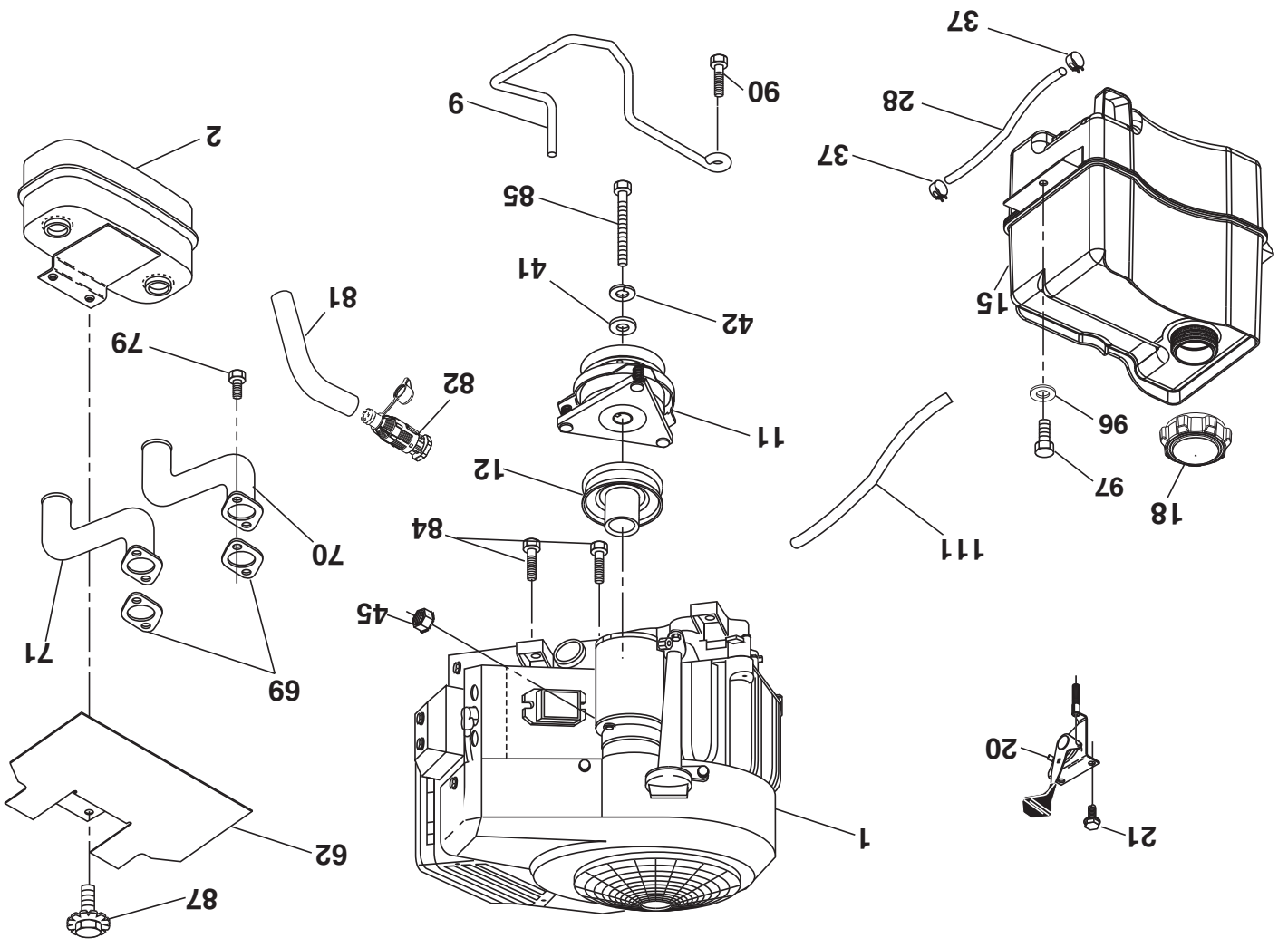

EQUIPO APAGACHISPAS

engine-tex_bs-2cyl_75

29

CÓDIGO MFG.	NO.	PIEZA NO.	DESCRIPCIÓN
1	---	---	TRANJESE.TUFTTORO K46BA (408214) (HAGA EL PEDI-
2	532 12 35-83	21546070	LLAVE CUADRADA.2.0 X .1845/.1865
15	819 13 13-16	21546284	ARANDELA.13/32 X 13/16 X 16 CALIBRE
17	532 41 36-78	21546654	FRENE DE RESSORTE
22	532 19 76-60	21546450	VARILLA
23	532 14 08-45	21546844	CON EL BOTÓN.1/2-13 UNC
29	532 40 38-06	21546593	VARILLA DEL FRENO
33	812 00 00-01	21546051	E-ANILLO.#5133-75
35	532 19 72-75	21547556	VARILLA DEL FRENO DE MANO
42	532 12 48-72	21547538	CUBIERTA DEL PEDAL
49	872 11 06-14	21546766	PERNO.3/8-16 UNC X 1-3/4.GR5
50	532 19 43-27	21546331	GUÍA PLANA DE EMBRAGUE.910"DESVIACION
51	873 90 06-00	21546790	TUERCA.3/8-16
52	532 19 43-26	21546330	GUÍA.910"DESVIACION
56	532 13 09-69	21546080	V-CORREA.92.40.42/K46
64	532 19 62-00	21546387	ENSAMBLE DEL EJE DEL
70	532 41 13-29	21547563	CONSOLA DEL CAMBIO
73	874 49 05-44	21546798	PERNO 5/16-18 GR. 5
74	532 14 24-32	21546106	TORNILLO.1/4X1/2UNC
80	532 44 06-19	21547733	CORREA DE TORSIÓN.K46/18"TEX
99	532 41 57-42	21546674	VARILLA DEL ENSAMBLE CON RESORTE DE
116	873 90 05-00	21546789	TUERCA.5/16-18 UNC
125	817 00 05-12	21546180	TORNILLO.5/16-18 X 3/4.SMGML.TAP/BL
143	817 49 05-08	21546199	TORNILLO.5/16-18 X 1/2TYTT
153	532 12 47-88	21547536	RETÉN DEL RESORTE
159	876 02 04-12	21546820	PASADOR DE CHAVETA.1/8 X 3/4.CAD.
160	532 16 94-84	21546178	ABRAZADERA DE RETENCIÓN(M).DIA.290
161	532 10 57-09	21546028	RESORTE DE RETORNO DEL EMBRAGUE.6.75
166	532 42 91-64	21547349	TUERCA.625
167	532 40 52-57	21546608	PESTILLO DEL FRENO DE MANO
170	532 19 43-22	21546648	SUJETADOR DE LA CORREA CENTRAL.1.688
171	872 11 06-16	21546767	TORNILLO 3/8-16 UNC X 2
174	532 19 72-89	21546431	TUERCA.500
175	532 40 62-08	21547558	ENSAMBLE DEL EJE
176	532 19 62-14	21546394	BRAZO DE LA POLEA
178	532 19 74-56	21546445	RETORNO DE MUELLE.GT.2006
183	532 13 70-57	21546087	SEPARADOR DEL EJE
184	532 44 16-36	21547738	MANIJA DEL FRENO DE MANO
185	872 11 06-22	21546768	PERNO.3/8-16 UNC X 2-3/4 GR5
186	532 19 43-21	21546328	ESPACIADOR DE RETENCIÓN
187	819 13 32-10	21546287	ARANDELA.13/32 X 2 X 10 CALIBRE
188	532 19 43-23	21546329	MECANISMO DE DESPLAZAMIENTO DE LA
189	532 19 43-17	21546324	VARILLA DE MANDO DEL EMBRAGUE
190	532 19 43-18	21546325	SUJETADOR DE LA PALANCA ACODADA DEL
196	817 00 06-16	21546182	TORNILLO 3/8-16 X 1
197	532 19 58-04	21546374	VARILLA DE MANDO DEL EMBRAGUE
205	532 12 17-48	21546066	ARANDELA.25/32 X 1-5/8 X 16 CALIBRE
211	532 19 62-12	21546393	BUJE DE DIRECCIÓN
216	532 19 61-31	21546385	SOPORTE
221	532 40 31-87	21546588	ABRAZADERA DE RETENCIÓN DEL RESORTE
225	532 40 33-19	21546589	SUJETADOR DE LA CORREA .K46
226	532 40 15-64	21546575	SOPORTE.K46.TLT
227	817 49 05-12	21547613	TORNILLO 5/16-18 X 3/4
230	532 18 89-67	21546272	ARANDELA.793 X 1.637 X 060
232	874 78 07-16	21546818	PERNO.7/16-14X1 GR5
233	532 40 52-96	21546609	ARANDELA
279	532 40 62-07	21547580	CONEXIÓN DEL CAMBIO

NOTA: Las dimensiones de todos los componentes están expresadas en pulgadas americanas.
1 pulgada = 25,4 mm

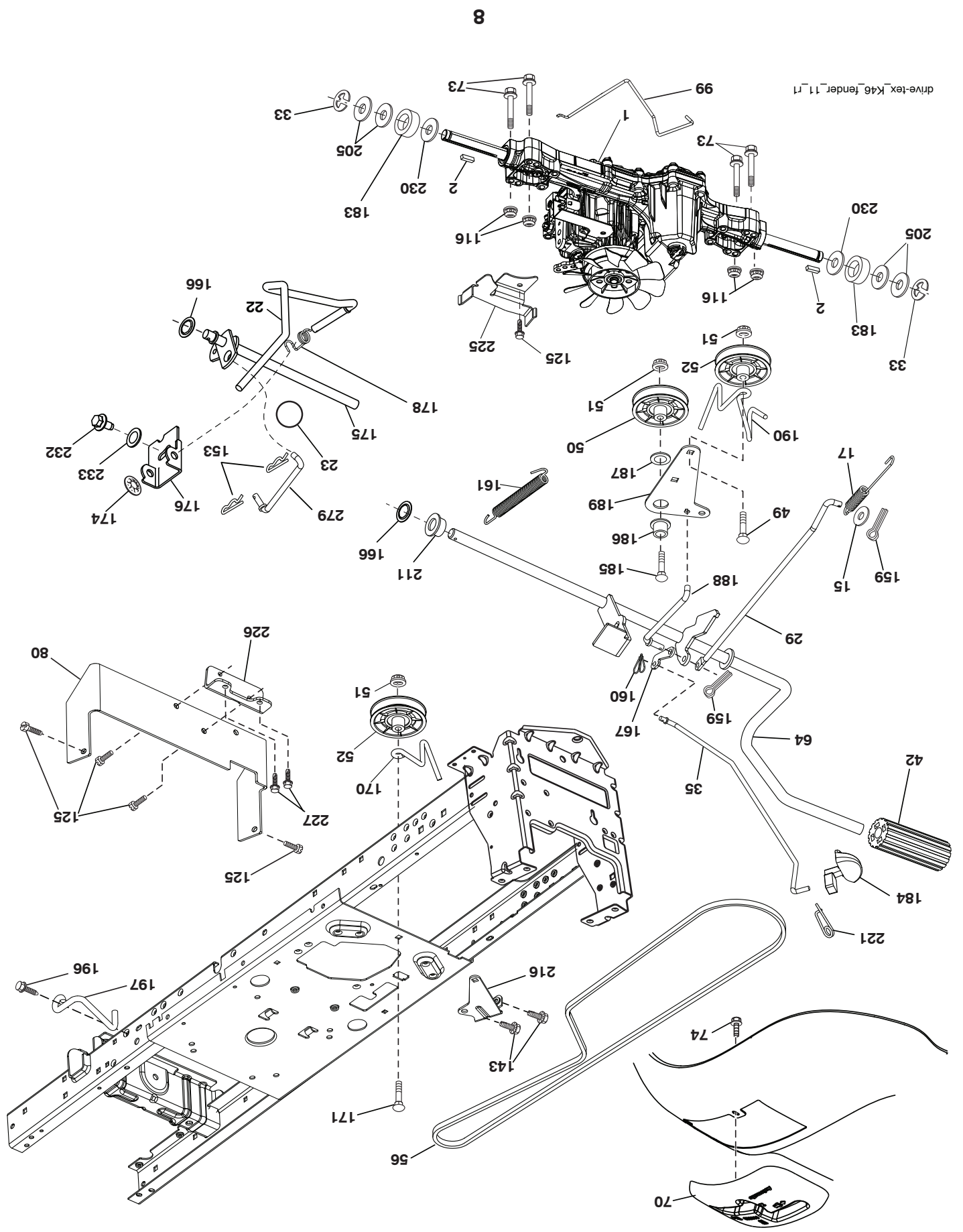

drive-tex_K46_fender_11_r1

CÓDIGO MFG.	NO.	NO.	DESCRIPCIÓN
		PIEZA NO.	
		ARIENS	
532 44 11-25	5	21547736	TABLERO
532 44 18-22	14	21547739	CAPOTA
532 16 18-41	15	21547543	LENTE
532 18 71-14	18	21547551	PARRILLA
532 16 18-42	25	21547544	LENTE (LD)
532 19 61-25	34	21546384	PLACA MOTOR CHASIS
817 06 05-12	36	21546187	PERNO.5/16-18 X 3/4
532 44 12-66	37	21547643	GUARDABARRIOS
817 49 05-08	68	21546199	PERNO.5/16-18 X 1/2
532 19 25-12	122	21547529	TORNILLO
532 41 63-58	130	21546675	PERNO
532 16 46-55	137	21547545	CUBIERTA DEL CAPOTA
532 40 97-30	138	21547560	PORTAVASOS
532 17 18-73	139	21547301	PERNO.5/16-18 X 3/4
532 19 03-08	150	21547552	CUBIERTA TÉRMICA DEL CONDUCTO
532 17 02-00	151	21547546	SOPORTE
532 19 95-35	152	21546501	PROTECCIÓN
532 43 92-58	153	21547530	CAJA DEL FARO
817 00 06-12	159	21546181	PERNO.THDR3/8-16 X 3/4.BL
532 14 24-32	162	21546106	PERNO.1/4X1/2 UNC
532 19 32-36	175	21547554	TRAVESANO
532 40 07-76	176	21546562	PERNO.#10-24 X 5/8.
532 19 52-27	177	21546356	BUJE DE LA DIRECCIÓN
532 19 54-57	180	21547555	CHASIS
532 40 47-96	181	21547557	BUJE DE DIRECCIÓN
532 19 25-51	182	21547553	TABLERO INFERIOR
874 52 05-20	183	21547383	PERNO.5/16-18 X 1-1/4
817 00 05-12	189	21546180	PERNO.5/16-18X3/4
873 90 05-00	194	21546789	SEGURIDAD.5/16-18
532 40 41-37	195	21547532	TAPÓN
532 43 95-30	196	21547812	CONSOA DE ASAMBLEA DE ESCRITORIO
532 18 71-11	205	21547549	CAMISA (LD)
532 18 71-12	206	21547550	CAMISA (LI)
532 19 51-61	228	21546343	ESPÁRRAGO
532 40 61-29	235	21546619	ESPACIADOR
873 93 05-00	236	21546793	SEGURIDAD.5/16-18
532 19 63-94	278	21547317	SUPPORT
817 60 04-06	287	21546204	PERNO.1/4-20 X 3/8
532 41 14-11	289	21547533	TAPÓN DE CONTROL DE VELOCIDAD
532 91 17-08	--	21547534	TAPÓN

NOTA: Las dimensiones de todos los componentes están expresadas en pulgadas americanas.
1 pulgada = 25,4 mm

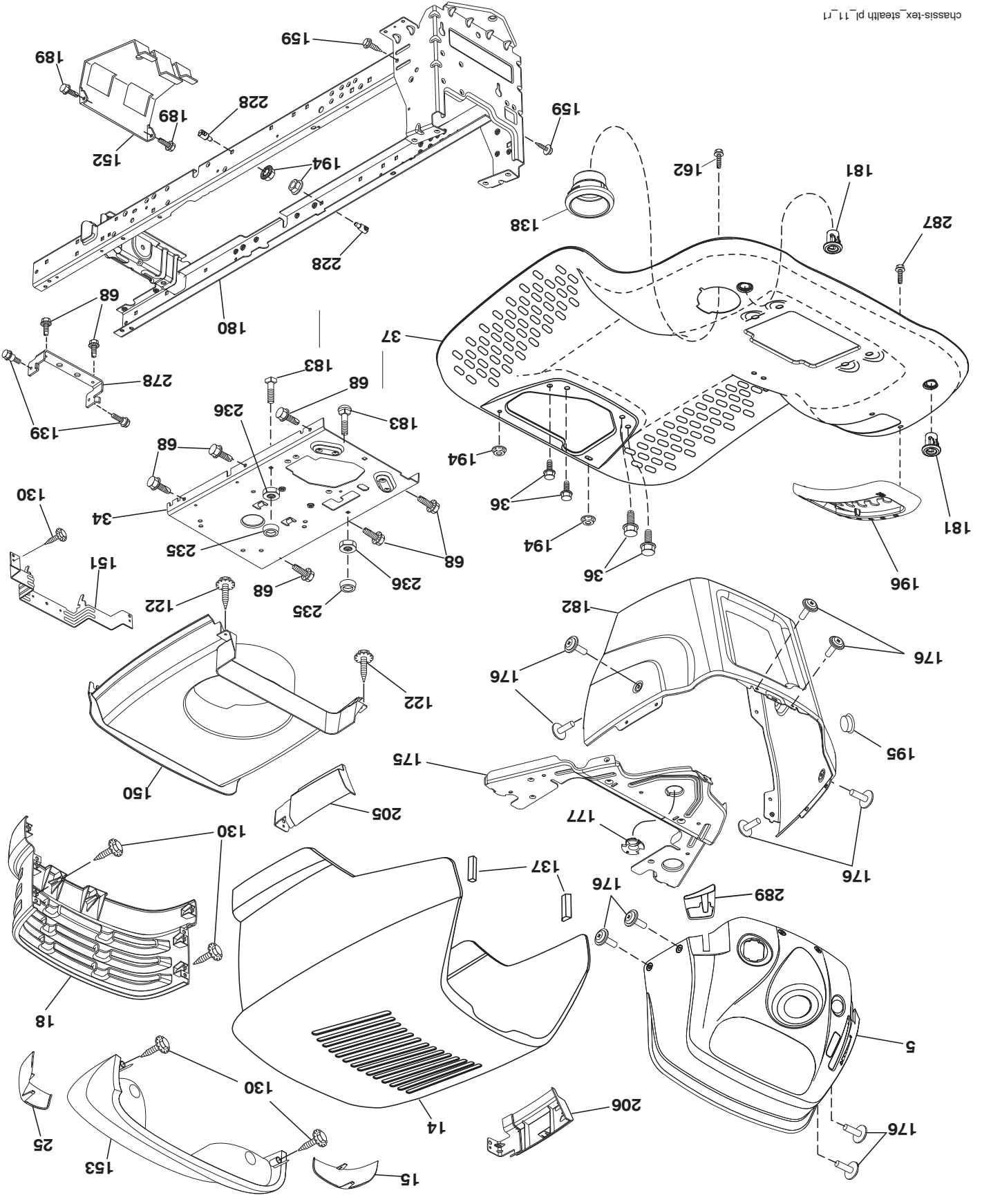

chassis-tex_stealth.pl 11 17

CÓDIGO MFG.	NO.	NO.	PIEZA NO.	DESCRIPCIÓN
532	16	34-65	21546162	BATERÍA
874	76	04-12	21546803	PERNO.1/4-20 X 3/4
532	19	32-28	21546315	PUERTA DE LA CAJA DE LA BATERÍA
532	17	56-88	21546226	ARREOS
532	00	41-52	21546673	BOMBILLA
532	41	28-95	21547566	CABLE
532	17	51-58	21546200	FUSIBLE
873	51	04-00	21546779	SEGURIDAD.1/4-20
532	19	88-85	21546481	CABLE 21"
532	40	15-45	21546574	INTERRUPTOR
532	19	33-50	21546319	INTERRUPTOR "ROS"
532	41	19-33	21547339	LLAVE/CADENA
532	11	07-12	21546050	INTERRUPTOR
532	40	96-14	21547336	ARREOS
817	72	04-08	21546210	TORNILLO.1/4-20 X 1/2
532	13	15-63	21546082	CUBIERTA.ROJO
532	19	25-07	21546294	SOLENOID.
532	17	46-51	21546196	INTERRUPTOR.PTO
817	06	05-12	21546187	TORNILLO.5/16-18X3/4
532	40	04-49	21546558	ARREOS
532	17	52-42	21546201	ASAMBLEA DE ENCHUFE
532	40	96-15	21547337	ARREOS
532	43	53-95	21547570	CUBIERTA DE LA TERMINAL
532	19	66-15	21546412	ARREOS
532	19	25-40	21546295	TORNILLO.10-14 X 2.0
532	19	18-34	21546849	MÓDULO INVERSO

NOTA: Las dimensiones de todos los componentes están expresadas en pulgadas americanas.
 1 pulgada = 25,4 mm

COMO UTILIZAR ESTE MANUAL

Este manual está diseñado para brindarle al comprador un medio para identificar las piezas del tractor para cuando necesite hacer el pedido de un repuesto. Las ilustraciones pueden o no representar los ensamblajes reales; por lo tanto, no se recomienda utilizar este manual como una guía para ensamblar o desarmar el tractor. Algunos accesorios y piezas están dibujados en tamaños más grandes para identificarlos con mayor facilidad.

Cada tractor tiene su propio número de modelo.

El número de modelo del tractor se encuentra en el guardabarros debajo del asiento. Cuando haga el pedido de una pieza, siempre brinde la siguiente información:

- Producto: "TRACTOR"
- NÚMERO DE MODELO: "936053 (96046002602)"
- Número de pieza
- Descripción de la pieza

TABLA DE MATERIAS

DIAGRAMA.....	3
DIAGRAMA ELÉCTRICO.....	4-5
CHASIS.....	6-7
TRANSMISIÓN.....	8-9
MOTOR.....	10-11
ENSAMBLE DE LA DIRECCIÓN.....	12-13
PLATAFORMA DE LA CORTADORA DE CÉSPED.....	14-15
ELEVACIÓN DE LA CORTADORA DE CÉSPED.....	16-17
ENSAMBLE DEL ASIENTO.....	18-19
CALCOMANÍAS.....	20-21
PARTES Y SERVICIO.....	22



TRACTOR DEL HIDROSTÁTICO

Manual de Partes



Modelos
936053 46" Tractor del hidrostático



ESPAÑOL **E**