

Instruction Sheet

Kit Number: 79222700

PRO-TURN 300 / 500 12V POWER OUTLET KIT



WARNING: FAILURE TO FOLLOW INSTRUCTIONS could result in personal injury and/or damage to unit.

Read, understand, and follow all safety practices in Operator's Manual before beginning.

IMPORTANT: All reference to left, right, front, or rear are given from the operator's position, facing the direction of forward travel.

Package Contents

Check the contents of your kit for the parts listed below. Also see Figure 1.

Item	Description	Qty	Ariens P/N
1	Left Control Panel	1	30157153
2	12V Power Port	1	04782900
3	12V Accessory Harness	1	30137700
4	J-Clamp	1	06909400

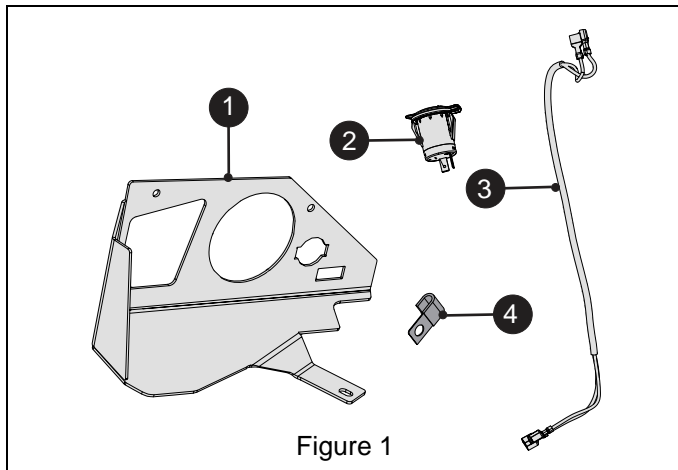

Figure 1

REMOVAL

1. Park unit on a flat surface.
2. Engage parking brake.
3. Stop engine and remove key. Wait for moving parts to stop and for hot parts to cool.

See Figure 2.

4. Disconnect and isolate battery negative (-) cable.
5. Remove and retain three hex head screws and one washer from left-side control panel.
6. Carefully remove and retain switch blank from left-side control panel.

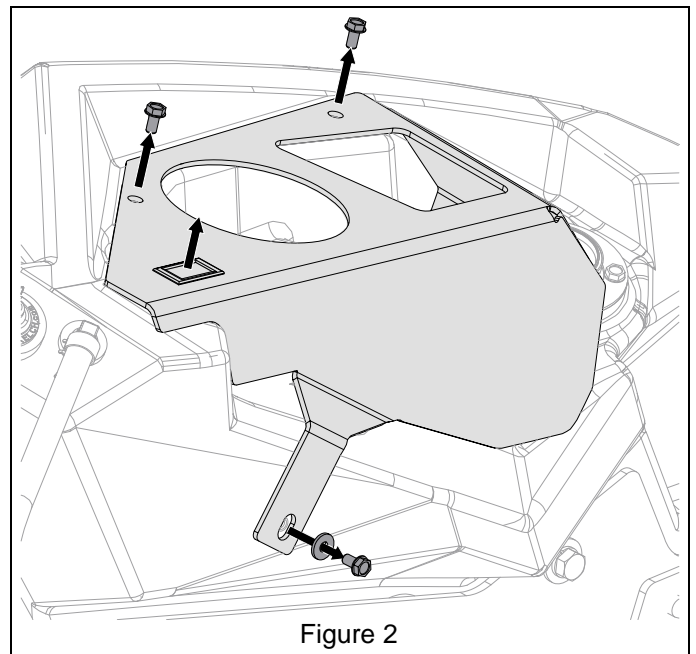

Figure 2

7. Remove and discard left control panel.

INSTALLATION

See Figure 3.

1. Install power port (item 2) into port cutout in left-side control panel (item 1), align prongs on port with holes in unit and snap port into position.
2. Insert switch blank into switch blank cutout in left-side control panel. Snap into place.

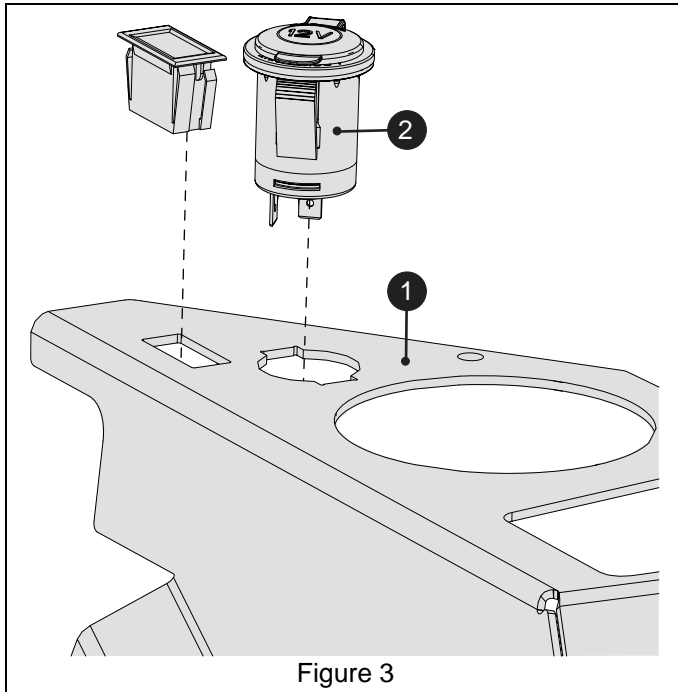

Figure 3

3. Connect accessory harness (item 3) to power port. Connect violet wire to positive (+) terminal and black wire to negative (-) terminal on 12V power port switch. See Figure 4.

CAUTION: Connecting incorrectly could damage accessories.

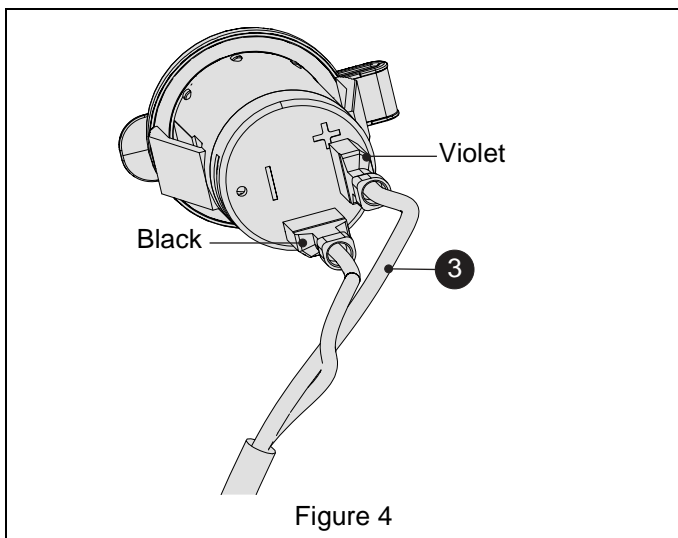

Figure 4

See Figure 5.

4. Ensure that all control panel connectors are fully seated and position control panel onto left-side tank routing wire harness through opening between control panel and fuel tank.

NOTICE: Ensure harness is properly routed.

5. Install control panel and J-clamp (item 4) using three hex head screws and one washer removed earlier. J-clamp is mounted using lower mounting hole.

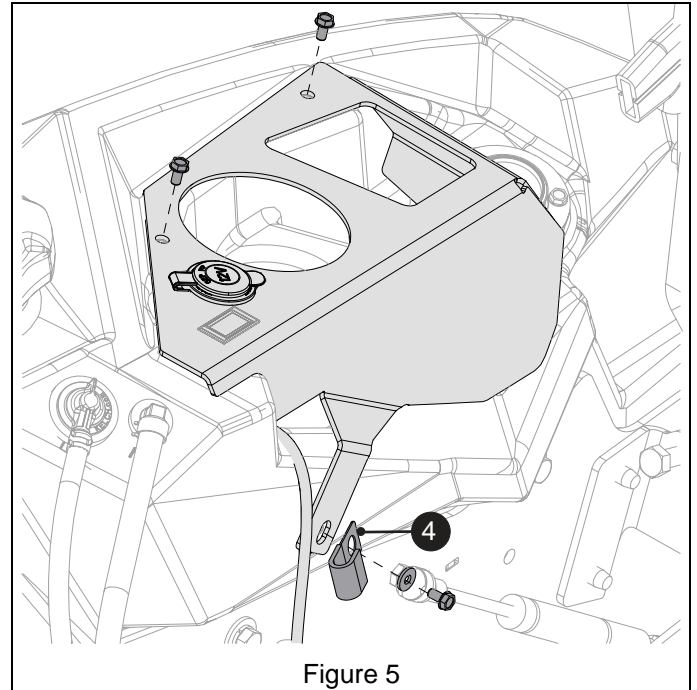
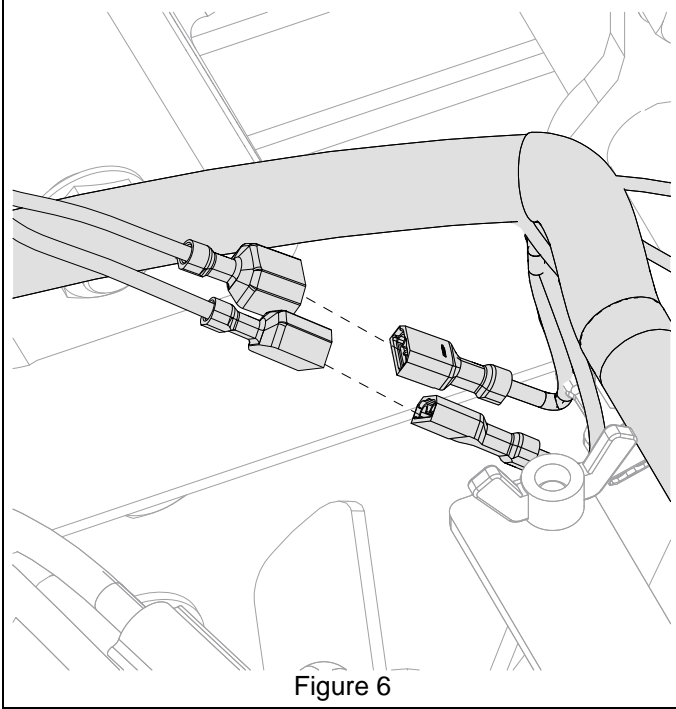

Figure 5

6. Locate wire harness auxiliary leads behind seat. Pull leads outward slightly for access.
7. Attach accessory harness to auxiliary leads. Attach purple lead to purple lead and black lead to black lead. See Figure 6.



8. Loosely route wire harness through J-clamp.
9. Reconnect battery negative cable and spark plugs.

OPERATION

Use the auxiliary power port to run compatible 12-volt accessories.

Keep the protective cap on the port when not in use.

IMPORTANT: Only use compatible accessories. DO NOT use with a 110-volt voltage inverter.

To reduce battery drain, only use accessories when the engine is running. To avoid battery- and electrical-system damage, DO NOT use high-draw accessories such as light kits. Turn accessories off before plugging into port.

NOTICE: DO NOT use port to charge sensitive electronic devices.

IMPORTANT: If port does not have power, check for blown fuses in the fuse box.