

Pro-Stance™



Operator's Manual
Manuel de l'utilisateur

GRAVELLY

Models

994149 – Pro-Stance 36
(SN 000101 +)

994157 – Pro-Stance 32
(SN 000101 +)

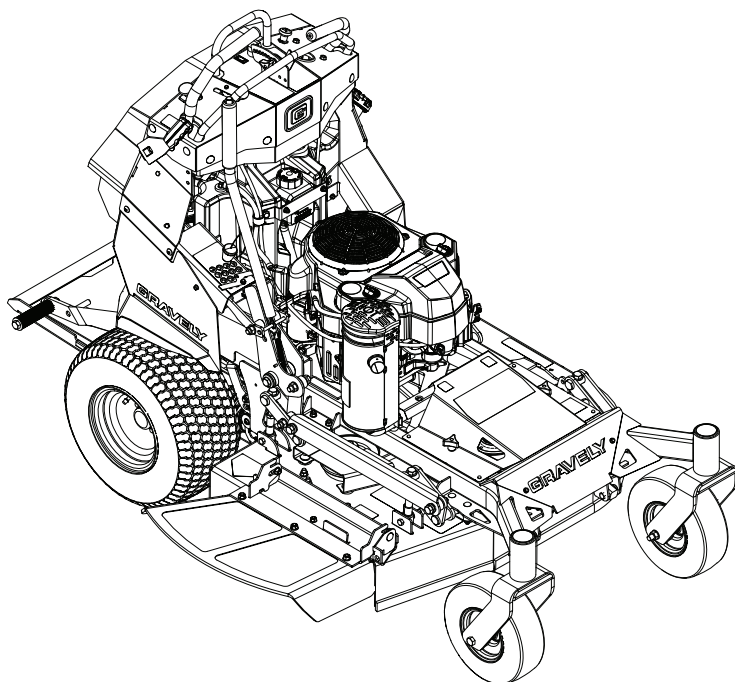

EN ENGLISH

FR FRANÇAIS

05268600 • 2/20

Printed in USA

TABLE OF CONTENTS

WELCOME	1	Move Unit Manually	18
Register Your Product!	1	MAINTENANCE	19
SAFETY	2	Service Position	19
Practices & Laws	2	Maintenance Schedule	20
Emission Control System	2	Service Parts	20
Required Operator Training	2	Check Safety Interlock System	20
Safety Alert Symbol	2	Check Hydraulic System	20
Signal Words	2	Check Tire Pressure	22
Safety Decals	3	Check Mower Blades	22
Safety Rules	5	Check Parking Brake	23
SETUP	11	Clean Battery	23
CONTROLS AND FEATURES	12	Charge Battery	24
Ignition Switch	14	Check Fasteners	24
Choke Control Knob	14	Lubricate Unit	24
Throttle Control Lever	14	SERVICE AND ADJUSTMENTS	25
Power Take-Off (PTO) Switch	14	Electrical Service	25
Oil Pressure Warning Light	15	Adjust Transaxles	26
Deck Lift Pedal	15	Adjust Steering Levers	27
Speed Control Bar	15	Adjust Unit to Drive Straight	28
Height-Of-Cut Adjustment System	15	Adjust Parking Brake	28
Deck Lift Lever	15	Replace Mower Belts	28
Transaxle Bypass Levers	15	Remove / Install Mower Deck	30
Hour Meter	15	Level And Pitch Mower Deck	31
Parking Brake Lever	15	Reverse Clutch Brake Plates	33
Steering Levers	15	TROUBLESHOOTING	34
Safety Interlock System	15	STORAGE	35
BEFORE OPERATION	16	Short-Term Storage	35
Set Cutting Height	16	Long-Term Storage	35
Set Operator Platform	17	Start-of-Season Preparation	35
OPERATION	17	ACCESSORIES	35
Emergency Stopping	17	SPECIFICATIONS	36
Start The Engine	17	WARRANTY	37
Operate Unit	17		
Stop The Engine	18		

WELCOME

Congratulations on your purchase and welcome to the Gravelly family! Every machine in the Gravelly lineup is designed for long-lasting and unsurpassed performance. We are confident your machine will be part of your family for many years to come.

Have Questions or Need Assistance?

www.gravelly.com

A parts manual for your unit is available for free download or purchase at www.gravelly.com.

Manual del operador español está disponible para su descarga gratuita o compra en www.gravelly.com.

REGISTER YOUR PRODUCT!

It is extremely important to register your product at time of purchase. Product registration activates the warranty and establishes a communication link from AriensCo.

Locate the model and serial number decal on your unit and register those numbers online at www.gravelly.com. See Figure 1 for decal location. Be aware that the original selling dealer may have already completed product registration on behalf of the original purchaser.

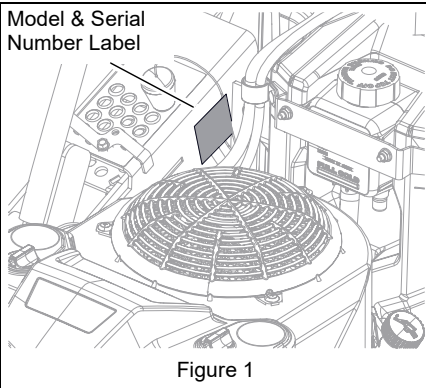

Record model number here.

Record serial number here.

MANUALS

Before operating or servicing the unit, carefully and completely read the manuals provided with the unit. They contain safety instructions and important information about unit controls.

The engine on this unit is covered by a separate manual. Refer to the engine manual for engine service recommendations. Contact the engine manufacturer for a replacement manual if necessary.

Your dealer must review important information in this manual with you before or upon delivery of the unit. It is your responsibility to read and understand all safety precautions and instructions in the manuals. If you do not understand or have difficulty following the instructions, contact your Gravelly dealer for assistance. To locate your nearest Gravelly dealer, go to www.gravelly.com.

DISCLAIMER

Gravelly reserves the right to discontinue, make changes to, and add improvements upon its products at any time without public notice or obligation. The descriptions and specifications contained in this manual were in effect at printing. Equipment described in this manual may be optional. Some illustrations may not be applicable to your unit.

SAFETY

Read these safety rules and follow them closely. Failure to follow these rules could lead to loss of control of unit, severe personal injury or death to you or bystanders, or result in damage to property or the unit.

PRACTICES & LAWS

Practice usual and customary safe working precautions. Learn applicable rules and laws in your area. ALWAYS follow the practices set forth in this manual.

EMISSION CONTROL SYSTEM

This equipment and/or its engine may include exhaust and evaporative emissions control system components required to meet U.S. Environmental Protection Agency (EPA) and/or California Air Resources Board (CARB) regulations. Tampering with emission controls and components by unauthorized personnel may result in severe fines or penalties. Emission controls and components can only be adjusted by a Gravelly dealer or an authorized engine manufacturer's service center. Contact your Gravelly Equipment Retailer concerning emission controls and component questions.

REQUIRED OPERATOR TRAINING



Read and understand the Operator's Manual and decals on the unit. This information is for your safety and the proper use of your equipment. Failure to follow these

instructions and warnings may cause death or serious injury. If you have purchased this product from a Gravelly dealer, the dealer can provide you with training.

Familiarize yourself and any other operators with all controls and the safe use of the features of this unit. If you loan, rent or sell this product to others, provide them with all manuals.

If you have any questions, please call our customer support line at 920-756-4688 or contact us at www.gravelly.com. Do not use this equipment if, after reading the Operator's Manual and the on-board decals, you have any questions about the safe use of this product.



WARNING: AVOID INJURY. This cutting machine is capable of amputating hands and feet and throwing objects. Failure to observe the safety instructions in the manuals and on decals could result in serious injury or death.

SAFETY ALERT SYMBOL



This is the safety alert symbol. It means:

- **ATTENTION!**
- **YOUR SAFETY IS INVOLVED!**

When you see this symbol:

- **BECOME ALERT!**
- **OBEY THE MESSAGE!**

SIGNAL WORDS

The safety alert symbols above and signal words below are used on decals and in this manual.

Read and understand all safety messages.

1. Danger



DANGER: Indicates an **IMMINENTLY HAZARDOUS SITUATION!** If not avoided, **WILL RESULT** in death or serious injury.

2. Warning



WARNING: Indicates a **POTENTIALLY HAZARDOUS SITUATION!** If not avoided, **COULD RESULT** in death or serious injury.

3. Caution



CAUTION: Indicates a **POTENTIALLY HAZARDOUS SITUATION!** If not avoided, **MAY RESULT** in minor or moderate injury. It may also be used to alert against unsafe practices.

4. Notice

NOTICE: Indicates information or procedures that are considered important but not hazard related. If not avoided property damage could result.

5. Important

IMPORTANT: Indicates general reference information worthy of special attention.

SAFETY DECALS

The safety decals on your machine are visual reminders of the important safety information in this manual. All messages on your unit must be fully understood and carefully followed. Safety decals on the machine are explained below.

ALWAYS replace missing or damaged safety decals. Replacement decal information is in the parts manual for your unit. Decals can be ordered from your dealer. See Figure 2 for safety decal locations.

Safety Decal Locations

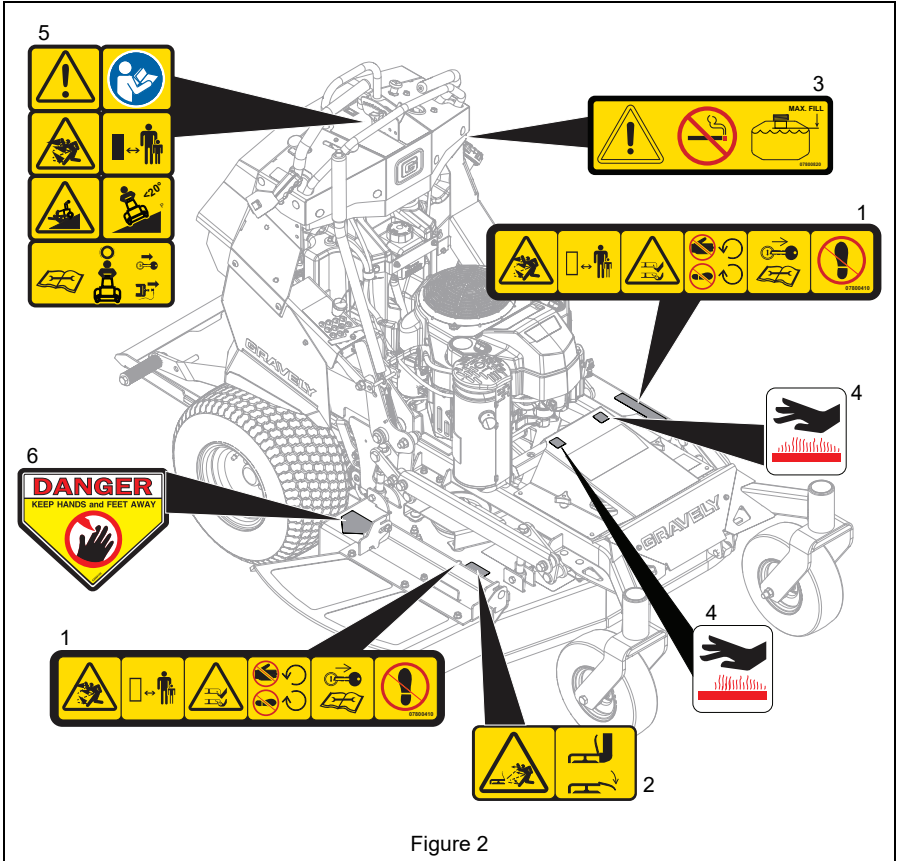

Figure 2

Safety Decal Descriptions

1. DANGER!



Discharge Hazard – NEVER direct discharge toward people, pets or property. Thrown objects can cause injury or damage.



Dismemberment Hazard – NEVER stick hands or feet under deck or shielded areas.



Shut off engine, remove key, and read manual before servicing or making adjustments to unit.



Keep children and others away from unit while unit is in operation.



Keep feet and hands away from all rotating or moving parts.



DO NOT step or stand in this area.

2. DANGER!



Discharge Hazard – NEVER operate unit without discharge chute in operating position. Thrown objects can cause injury or damage.



Do not operate mower unless all guards are in operating position or bagger is attached.

3. DANGER!



DANGER!



No smoking.

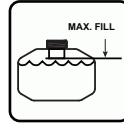

IMPORTANT: DO NOT overfill. Fill fuel tank to below bottom of filler neck.

WARNING: Overfilling may cause severe damage to evaporative system!

- Never fill fuel tank when engine is running, hot or unit is indoors. Never overfill fuel tank.
- Replace fuel cap securely and clean up spilled fuel.

4. HOT PARTS!



DO NOT touch parts which are hot from operation. ALWAYS allow parts to cool.

5. CAUTION!



CAUTION!



Read Owner/Operator Manual. Allow operation only by properly trained adult, never children.



Discharge Hazard – NEVER direct discharge toward people, pets or property. Thrown objects can cause injury or damage.



Keep children and others away from unit while unit is in operation.



Operating on slopes may cause the unit to tip unexpectedly. Do not tip mower while operating the unit. Mow across slopes, not up and down.



Look down and behind before and while backing. DO NOT operate on slopes over 20°. This maximum degree of operation is without attachments.

DO NOT operate on slopes over 10° when operating with attachments.



Read manual, set parking brake, remove key and remove spark plug before you adjust or repair unit.

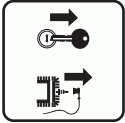

6. DANGER!



ALWAYS keep hands and feet away from discharge chute.

SAFETY RULES

The following safety instructions are based on the B71.4 specifications of the American National Standards Institute and ISO 5395 in effect at the time of production.

Training

Read, understand, and follow all instructions on the machine and in the manuals before starting.

Become familiar with the safe operation of the equipment, operator controls, and safety signs.

Be sure the area is clear of bystanders and pets before operating. Stop machine if anyone enters the area.

Improper use of power equipment can cause serious permanent injury or death to the operator or a bystander.

Understand:

- How to operate all controls
- The functions of all controls
- How to STOP in an Emergency
- Braking and steering characteristics
- Turning radius and clearances

Read the Operator's Manual and other training material. If the operator(s) or mechanic(s) cannot read English, it is the owner's responsibility to explain this material to them.

All operators and mechanics should be trained. The owner is responsible for training the users.

Never let children or untrained people operate or service the equipment. Local regulations may restrict the age of the operator.

The owner/user can prevent and is responsible for accidents or injuries occurring to themselves, other people or property.

Operator Age

Do not allow children under the age of 18 to operate or service any outdoor power equipment.

Local regulations may restrict the age of the operator.

Data indicates operators age 60 years and above are involved in a large percentage of riding mower-related injuries. These operators should evaluate their ability to operate the riding mower safely enough to protect themselves and others from serious injury.

Children

Tragic accidents can occur if the operator is not alert to the presence of children. Children are often attracted to the machine and the mowing activity. Never assume that children will remain where you last saw them.

Be alert and turn machine off if a child enters the area.

Before and while backing, look behind and down for small children.

Never carry children, even with the blade(s) shut off. They may fall off and be seriously injured or interfere with safe machine operation. Children who have been given rides in the past may suddenly appear in the mowing area for another ride and be run over or backed over by the machine.

Never allow children to operate or service the machine.

Use extreme care when approaching blind corners, shrubs, trees, or other objects that may block your view of a child.

Keep children out of the mowing area and in the watchful care of a responsible adult other than the operator.

Personal Protection

Always wear appropriate clothing including hard hat, protective gloves, safety glasses and hearing protection. Long hair, loose clothing or jewelry may get tangled in moving parts.

DO NOT wear loose clothing or jewelry and tie back hair during operation.

Wear proper footwear to improve footing on slippery surfaces. NEVER wear open sandals or canvas shoes during operation.

Before Operating

Evaluate the terrain to determine what accessories and attachments are needed to properly and safely perform the job. Only use accessories and attachments approved by the manufacturer.

Inspect the area where the equipment is to be used and remove all objects such as rocks, toys and wire which can be thrown by the machine.

Keep all nuts and bolts tight to be sure the equipment is in safe working condition.

Maintain the machine to be in compliance with the maintenance schedule.

Clean grass and debris from unit, especially from around muffler and engine, to help prevent fires.

Check parking brake operation frequently. Adjust and service as required.

Inspect unit before each use for missing or damaged decals and shields, correctly operating safety interlock system, and deterioration of grass catchers. Replace or repair as needed.

Check that operator's presence controls, safety switches and shields are attached and functioning properly. Do not operate unless they are functioning properly.

Ensure Safety Interlock System is functioning properly. DO NOT operate unit if safety interlock is damaged or disabled.

Be sure all drives are in neutral and parking brake is engaged before starting engine. Steering control levers must be in neutral and PTO disengaged. Only start engine from the operator's position. Use seat belts if provided.

Operate unit only when standing in operator zone.

Be sure the area is clear of bystanders and pets before operating.

Never tamper with safety devices. Check their proper operation regularly.

Keep machine free of grass, leaves, or other debris build-up. Clean up oil or fuel spillage and remove any fuel-soaked debris.

Operation

Never operate machine in a closed or poorly ventilated area. Never run an engine in an enclosed area.

ALWAYS maintain unit in safe operating condition. Damaged or worn out muffler can cause fire or explosion.

<p>This product is equipped with an internal combustion type engine. DO NOT use unit on or near any unimproved, forest-covered or brush covered land unless exhaust system is equipped with a spark arrester meeting applicable local, state or federal laws. A spark arrester, if it is used, must be maintained in effective working order by operator.</p>
<p>DO NOT operate machine while feeling tired, ill or under the influence of alcohol or other drugs.</p>
<p>Do not change the engine governor setting or overspeed the engine.</p>
<p>Do not operate the mower under the influence of alcohol or drugs.</p>
<p>Keep hands and feet away from the cutting units. Do not put hands or feet near rotating parts or under the machine. Keep clear of the discharge opening at all times.</p>
<p>DO NOT touch parts which are hot. Allow parts to cool.</p>
<p>Never operate with the discharge deflector raised, removed or altered, unless using a grass catcher. Make sure other safety devices are in place and working.</p>
<p>Always keep hands and feet away from all pinch points.</p>
<p>Avoid slippery surfaces. Be sure of your footing while using pedestrian controlled equipment, especially when backing up. Walk, don't run. Use extreme caution if operating on wet grass, reduced footing could cause slipping.</p>
<p>Never carry passengers and keep pets and bystanders away. Stop machine if anyone enters the area.</p>
<p>Be aware of the mower discharge direction and do not point it at anyone. Never direct discharged material toward anyone. Avoid discharging material against a wall or obstruction. Material may ricochet back toward the operator. Stop the blade(s) when crossing gravel surfaces.</p>
<p>Never engage PTO when attachment, including mower blades, is not in use. Always turn off power to attachment when not in active use such as traveling or crossing driveways.</p>
<p>Slow down and use caution when making turns and crossing roads and sidewalks. Stop blades if not mowing.</p>

<p>Stop on level ground, lower implements, disengage drives, engage parking brake (if provided), disengage PTO, shut off engine and allow moving parts to stop before leaving the operator's position for any reason including emptying the catchers or unclogging the chute.</p>
<p>Never engage PTO while raising the attachment, including mower blades, or when attachment is in the raised position.</p>
<p>Never raise deck with the blades running.</p>
<p>Never operate with the PTO shield, or other guards not securely in place. Be sure all interlocks are attached, adjusted properly, and functioning properly. Never modify or remove safety devices.</p>
<p>Do not mow in reverse unless absolutely necessary. Always look behind and down before backing up to be sure of a clear path.</p>
<p>Stop equipment and inspect blades after striking objects or if an abnormal vibration occurs. Make necessary repairs before resuming operations.</p>
<p>Never leave a running machine unattended. Always turn off blade(s), set parking brake, stop engine and remove key before dismounting.</p>
<p>Disengage blade(s) when not mowing. Shut off engine and wait for all parts to come to a complete stop before cleaning the machine, removing the grass catcher, or unclogging the discharge guard.</p>
<p>Know the weight of loads. Limit loads to those you can safely control and the unit can safely handle.</p>
<p>Use care when loading or unloading the machine into a trailer or truck.</p>

<p>Operating Conditions</p>
<p>Lightning can cause severe injury or death. If lightning is seen or thunder is heard in the area, do not operate the machine; seek shelter.</p>
<p>Always check overhead and side clearances carefully before operation.</p>
<p>Watch for traffic when operating near or crossing roadways.</p>
<p>Ensure the area is cleared of objects such as rocks, wire, toys, etc., which could be thrown by the blades prior to operation.</p>
<p>Check for weak spots on docks, ramps or floors. Avoid uneven work areas and rough terrain. Stay alert for hidden hazards or traffic.</p>

Always use ramps to climb curbs to prevent personal injury or equipment damage.
Use care when approaching blind corners, shrubs, trees or other objects that may obscure vision.
Dust, smoke, fog, etc. can reduce vision and cause an accident.
Only operate in good light, keeping away from holes and hidden hazards.

Slope Operation

Slopes are a major factor related to loss of control and tip-over accidents, which can result in severe injury or death. Operation on all slopes requires extra caution. If you cannot back up the slope or if you feel uneasy on it, do not mow it.
DO NOT operate on slopes of more than 20°. This maximum degree of operation is without attachments.
Do not operate on slopes of more than 10° with attachments such as grass catchers installed.
Mow across slopes, not up and down.
DO NOT operate the mower on slopes at all when the grass is wet.
DO NOT operate on slopes steeper than you can feel secure about the traction of the tires and the stability of the mower.
Watch for holes, ruts, bumps, rocks, or other hidden objects. Uneven terrain could overturn the machine. Tall grass can hide obstacles.
Do not mow on moist or wet grass. Tires may lose traction causing a loss of control.
Use extra care while operating machine with grass catchers or other attachments; they can affect the stability of the machine. Do not use on steep slopes.
Slow down and use caution when making turns and when changing directions on slopes. Keep all movements on the slope <i>slow</i> and <i>gradual</i> . Sudden changes in speed or direction could cause the machine to roll over.
Avoid starting, stopping, or turning on a slope. If the tires lose traction, disengage the blade(s) and proceed slowly straight down the slope.

Operation on slopes may lead to loss of steering control. When operating on slopes be prepared to react to an emergency situation: <ul style="list-style-type: none"> • Return steering levers to neutral position. • Immediately set parking brake. • Turn off PTO and engine.
DO NOT try to stabilize the machine by putting your foot on the ground.
DO NOT park on slopes unless necessary. When parking on slope always chock or block wheels. Always set parking brake.
Choose a low ground speed so you will not have to stop or shift while on a slope.
Slow down and use extra care on hillsides. Be sure to travel in the recommended direction on hillsides. Turf conditions can affect the machine's stability. Use caution while operating near drop-offs.
DO NOT operate near drop-offs, ditches, or embankments. Unit can suddenly turn over if a wheel is over the edge of a cliff or ditch, or if an edge caves in.
Do not bypass transmission or allow transmission to free-wheel when on a slope.

Fuel

To avoid personal injury or property damage, use extreme care in handling gasoline. Gasoline is extremely flammable and the vapors are explosive.
Ethanol blends must not exceed E10. Higher ethanol content may cause your machine to run hotter and damage your engine.
Replace fuel cap securely and clean up spilled fuel before starting engine.
Extinguish all cigarettes, cigars, pipes, and other sources of ignition.
Use only an approved fuel container.
Never store the machine or fuel container where there is an open flame, spark, or pilot light such as on a water or space heater or other appliances.
Never fill containers inside a vehicle or on a truck or trailer bed with a plastic liner. Always place containers on the ground away from your vehicle before filling.
Never refuel the machine indoors.
Never remove fuel cap or add fuel with the engine running. Allow engine to cool before refueling.

Fuel is highly flammable and its vapors are explosive. Handle with care. Use only an approved gasoline container with an appropriately sized dispensing spout.
NO smoking, NO sparks, NO flames.

Remove equipment from the truck or trailer and refuel it on the ground. If this is not possible, then refuel such equipment with a portable container, rather than from a gasoline dispenser nozzle.

Keep the nozzle in contact with the rim of the fuel tank or container opening at all times until the fueling is complete. Do not use a nozzle lock open device.

Never overfill fuel tank. Replace fuel cap and tighten securely.

If fuel is spilled on clothing, change clothing immediately.

DO NOT OVERFILL! This equipment and/or its engine may include evaporative emissions control system components, required to meet EPA and/or CARB regulations, that will only function properly when the fuel tank has been filled to the recommended level. Overfilling may cause permanent damage to evaporative emissions control system components. Filling to the recommended level ensures a vapor gap required to allow for fuel expansion. Pay close attention while filling the fuel tank to ensure that the recommended fuel level inside the tank is not exceeded. Use a portable gasoline container with an appropriately sized dispensing spout when filling the tank. Do not use a funnel or other device that obstructs the view of the tank filling process.

Towing

Do not attach towed equipment or accessories. This vehicle is not designed to tow.

Accessories

Follow the manufacturer’s recommendation for wheel weights or counterweights

Attachments reduce the maximum operating slope angle. DO NOT operate on slopes over 10° when operating with attachments.

Check grass catcher components and the discharge guard frequently and replace with the manufacturer’s recommended parts, when necessary.

Use only attachments recommended by AriensCo that are appropriate to your use and can be used safely in your application.

Batteries

Avoid Electric Shock. Objects contacting both battery terminals at the same time may result in injury and unit damage. DO NOT reverse battery connections.

Reverse connections may result in sparks which can cause serious injury. Always connect positive (+) lead of charger to positive (+) terminal, and negative (-) lead to negative (-) terminal.

ALWAYS disconnect negative (-) cable FIRST and positive (+) cable SECOND. ALWAYS connect positive (+) cable FIRST, and negative (-) cable SECOND.

Explosive Gases from battery can cause death or serious injury. Poisonous battery fluid contains sulfuric acid and its contact with skin, eyes or clothing can cause severe chemical burns.

No flames, No sparks, No smoking near battery.

Charge batteries in an open well ventilated area, away from spark and flames. Unplug charger before connecting or disconnecting from battery. Always wear protective clothing and safety glasses near battery and use insulated tools.

ALWAYS keep batteries out of reach of children.

Battery posts, terminals and related accessories contain lead and lead compounds, chemicals known to the State of California to cause cancer and reproductive harm. Wash hands after handling.

Service

The use of non-genuine replacement parts or accessories could adversely affect machine operation and safety.

Do not change engine governor setting or overspeed the engine

Park machine on level ground. Never allow untrained personnel to service machine.

Disconnect battery or remove spark plug wire before making any repairs. Disconnect the negative terminal first and the positive last. Reconnect positive first and negative last.

Keep all parts in good working condition and all hardware tightened. Replace all worn or damaged decals.
Keep unit free of debris. Clean up oil or fuel spillage.
ALWAYS block wheels and know all jack stands are strong and secure and will hold weight of unit during maintenance. Use jack stands to support components when required.
Carefully and slowly release any pneumatic or hydraulic pressure from components with stored energy.
ALWAYS keep body and hands away from pin holes or nozzles which eject hydraulic fluid under pressure.
NEVER attempt to make any adjustments or repairs to unit while engine is running (except where specifically recommended). Disengage drives, lower implement, set parking brake, stop engine and remove key or disconnect spark plug wire. Wait for all movement to stop before adjusting, cleaning or repairing.
Keep hands and feet away from moving parts. If possible, do not make adjustments with the engine running.
Lower cutting deck unless a positive mechanical lock is used.
Allow engine to cool before servicing.
Moving parts can cut or amputate fingers or a hand. On multiblade mowers, rotation of one blade will cause all blades to rotate.
Use care when checking blades. Wrap the blade(s) or wear gloves, use caution when servicing them. Replace damaged blades. Never straighten or weld them.

Transporting Unit
Use care when loading or unloading the machine into a trailer or truck.
Use full width ramps for loading machine into trailer or truck.
Secure unit chassis to transport vehicle. Never secure from rods or linkages that could be damaged. Tie the machine down securely using straps, chains, cable, or ropes. Both front and rear straps should be directed down and outward from the machine.
Do not transport machine while engine is running.
ALWAYS turn off power to attachment and shut off fuel when transporting unit.

Storage
NEVER store unit with fuel in fuel tank, inside a building where any ignition sources are present.
Clean grass and debris from cutting units, drives, mufflers, and engine to help prevent fires. Clean up oil or fuel spillage. Let engine cool before storing and do not store near flame.
Shut off fuel while storing or transporting. Do not store fuel near flames or drain indoors.
For extended storage, shut off fuel and clean unit thoroughly. See engine manual for proper storage.

SETUP



WARNING: AVOID INJURY.
Read and understand entire *Safety* section before proceeding.

NOTICE: Refer to *Controls And Features* on page 12 during setup.

1. Remove packaging and unit from container.
2. Open bypass valves. See *Move Unit Manually* on page 18.
3. Push unit onto a level surface.
4. Close bypass valves.
5. Check tire pressures. See *Check Tire Pressure* on page 22 and *Specifications* on page 36.
6. Clip cable tie and remove wrap from steering levers.
7. Check steering lever positions. See *Adjust Steering Levers* on page 27.
8. Check battery and charge if needed. See *Charge Battery* on page 24.
9. Check engine oil level and add if needed. Refer to the engine manual.
10. Check hydraulic fluid level and add if needed. See *Check Hydraulic Oil Level* on page 20.
11. Fill fuel tank with clean, fresh fuel.

IMPORTANT: See engine manual for fuel type.

12. Inspect all hardware and tighten if loose.
13. Check safety interlock system functions. See *Check Safety Interlock System* on page 20.



WARNING: FAILURE OF INTERLOCK together with improper operation can result in severe personal injury.

14. Lubricate all fittings. See *Maintenance Schedule* on page 20.
15. Place the discharge chute in the operating position.

CAUTION: Avoid Injury! Do not operate unit with discharge chute in operating position.

Transport Position

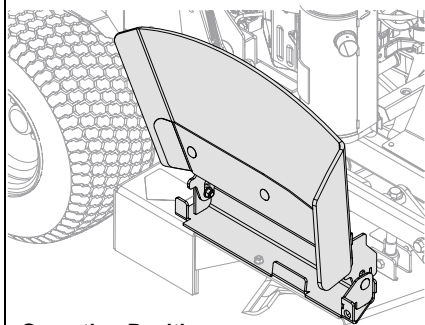

Operating Position

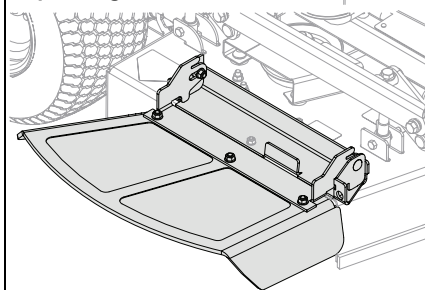

Figure 3

16. Check that mower deck is level per factory standards. See *Level And Pitch Mower Deck* on page 31.
17. Check all control functions and ensure unit operates properly. See *Controls And Features* on page 12.



WARNING: FAILURE OF CONTROLS could result in death or serious injury.

CONTROLS AND FEATURES

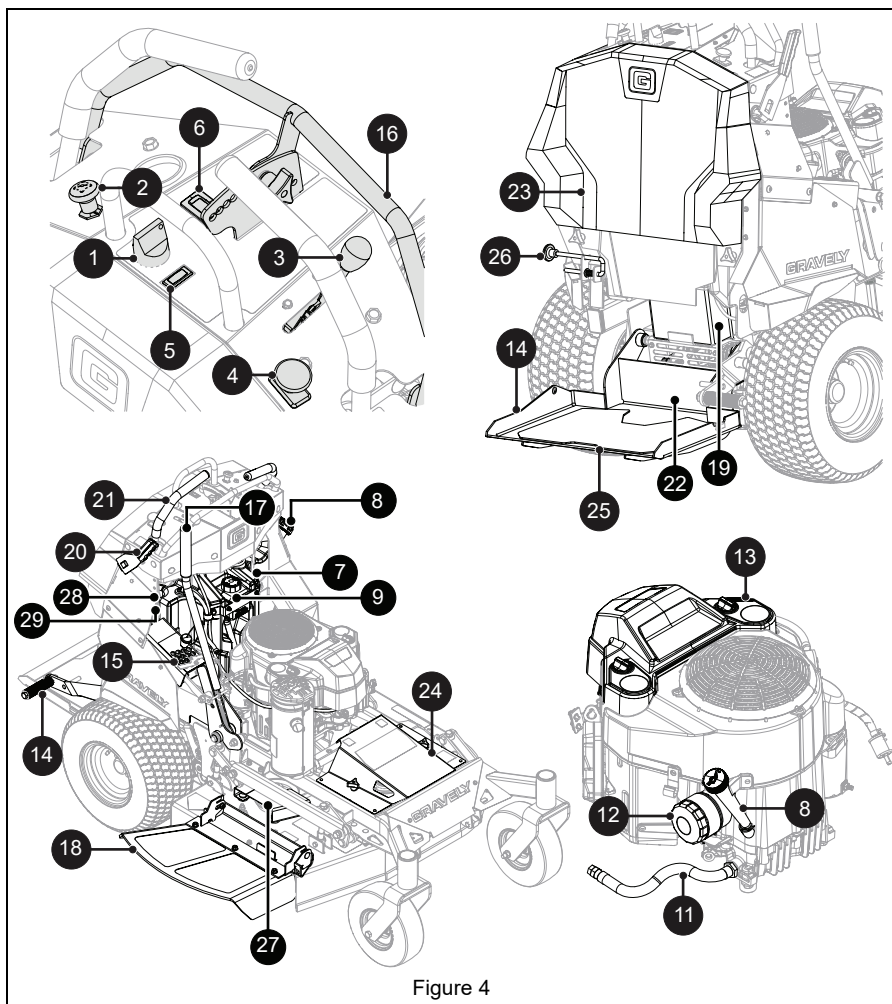

Figure 4

1. Ignition Switch
2. Choke Control Knob
3. Throttle Control Lever
4. Power Take Off (PTO) Switch
5. Oil Pressure Warning Light
6. Hour / Maintenance Meter
7. Fuel Tank
8. Fuel Cap
9. Hydraulic Oil Expansion Tank
10. Oil Fill / Dipstick
11. Oil Drain
12. Engine Oil Filter
13. Air Filter Cover
14. Deck Lift Pedal
15. Height-of-Cut (HOC) Adjustment System
16. Speed Control Bar
17. Deck Lift Lever
18. Discharge Chute
19. Battery
20. Parking Brake Lever
21. Steering Lever (2)
22. Transaxle Bypass Lever (2)
23. Rear Access Pad
24. Belt Access Panel
25. Operator Platform
26. Operator Platform Latch
27. Belt Cover (2)
28. Fuse Box (Below Control Panel)
29. Relay (Below Control Panel)



WARNING: AVOID INJURY.
Read and understand entire
Safety section before
proceeding.

See Figure 4 for Controls and Features
locations.

IGNITION SWITCH

See Figure 5.

Controls power to the engine. The key cannot
be removed when in the on position.

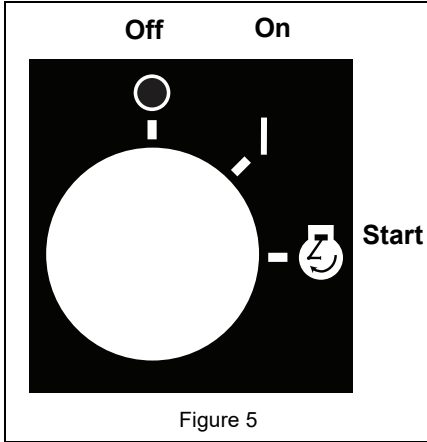

Figure 5

CHOKE CONTROL KNOB

See Figure 6.

Controls air intake to the engine.

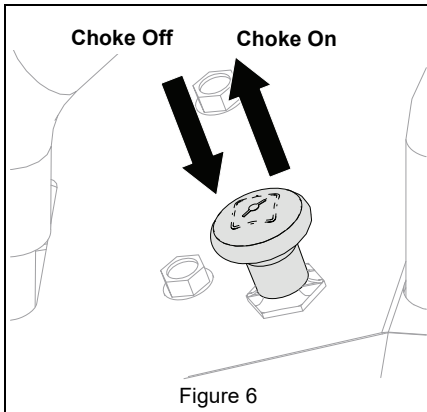

Figure 6

THROTTLE CONTROL LEVER

See Figure 7.

Controls engine speed.

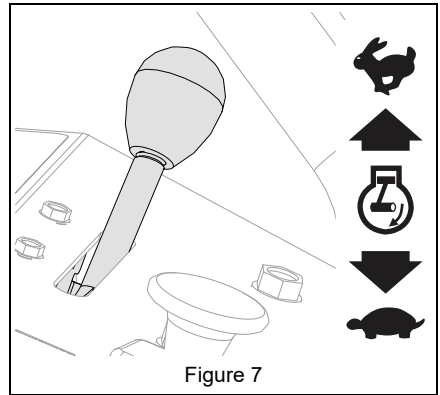

Figure 7

POWER TAKE-OFF (PTO) SWITCH

See Figure 8.

Controls power to mower blades. The engine
will not start with the PTO switch in the on
position.

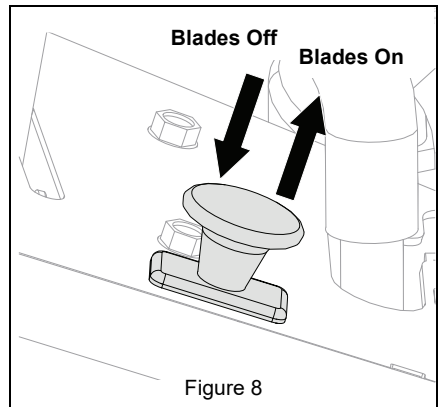
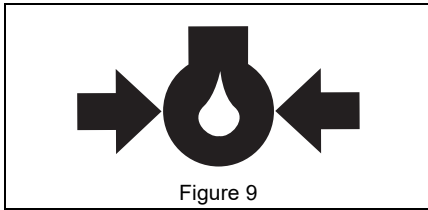

Figure 8

OIL PRESSURE WARNING LIGHT

See Figure 9.

Illuminates when oil pressure is low. Stop engine immediately and refer to engine manual.



DECK LIFT PEDAL

Raises mower deck to change height-of-cut setting.

SPEED CONTROL BAR

Controls the speed of forward travel. Remove thumb screw and reinstall into the desired speed setting.

HEIGHT-OF-CUT ADJUSTMENT SYSTEM

Height-of-cut (HOC) pin box sets desired cutting height or transport position.

DECK LIFT LEVER

Deck lift lever or pedal raises and lowers mower deck for mowing or transport.

TRANSAXLE BYPASS LEVERS

Engage and disengage transaxles so unit can be moved with the engine off.

HOUR METER

See Figure 10.

Hour meter measures engine runtime and cannot be reset.

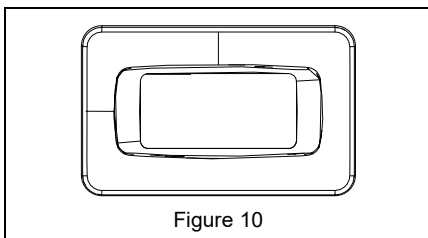

PARKING BRAKE LEVER

See Figure 11.

Engages the parking brake. The engine will not start when brake is released.

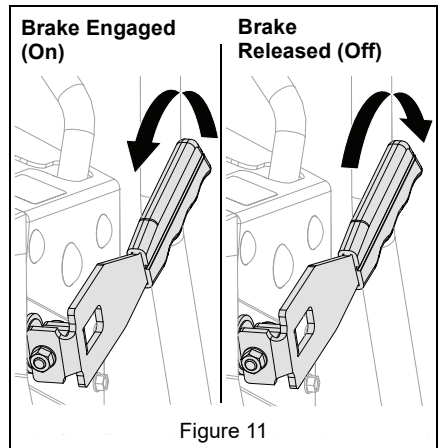

STEERING LEVERS

Control the direction and speed of unit. The levers gradually return to neutral when released and are locked in neutral when parking brake is engaged.

SAFETY INTERLOCK SYSTEM

Monitors the interaction of various unit features for operator safety.

BEFORE OPERATION



WARNING: AVOID INJURY.
Read and understand the Safety section before proceeding.

1. Know how to stop in an emergency. See *Emergency Stopping* on page 17.
2. Check fuel level and add fuel if needed.

IMPORTANT: Use fresh unleaded fuel with an octane rating of at least 87. DO NOT use E85 blended fuels; the engine is not E20 / E30 / E85 compatible. The maximum recommended ethanol content is 10%. Gravely recommends using a quality fuel stabilizer in all fuel. See *Short-Term Storage* on page 35.

3. Check engine oil level and add oil if needed. Refer to engine manual.
4. Check hydraulic oil level. See *Check Hydraulic Oil Level* on page 20.
5. Check condition of air cleaner. Refer to engine manual.
6. Check function of all controls.
7. Check function of the Safety Interlock System by performing the tests below. Contact your Gravely dealer for repair if any of the tests fail.



WARNING: AVOID INJURY.
Failure of Safety Interlock System together with improper operation can result in severe personal injury.

Test	Steering Levers	PTO	Parking Brake	Result
Starting Interlock				
1	Neutral	Off	On	Engine starts.
2	Forward, Neutral, Reverse	On	On or Off	Engine does not start.
3	Forward, Neutral, Reverse	On or Off	Off	Engine does not start.
Operating Interlock (Engine On)				
4 *	Forward, Neutral, Reverse	On	On or Off	Engine shuts off.
5 *	Forward, Neutral, Reverse	On or Off	Off	Engine shuts off.
* When operator lifts operator presence control arm				

SET CUTTING HEIGHT

See Figure 12.

1. Set HOC range. See *Adjust Deck Height* on page 32.
2. Push down on mower lift pedal or pull lift lever rearward to release deck pressure from HOC pin.
3. Insert HOC pin to desired setting.
4. Release mower lift pedal or lift lever.

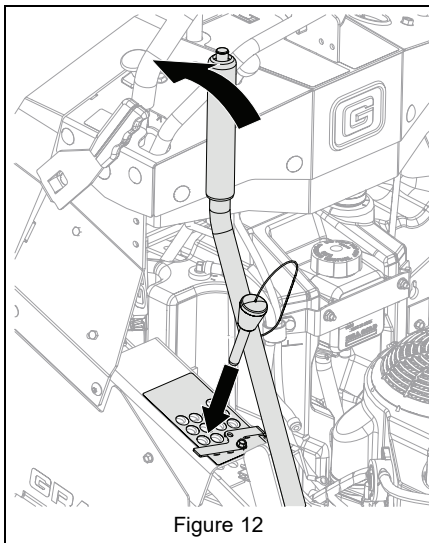

Figure 12

SET OPERATOR PLATFORM



CAUTION: Platform will drop when latch is released. Stand clear when releasing platform.

See Figure 13.

To rotate platform up:

1. Rotate platform up and push in platform lock pin.
2. Release pin to secure through platform hole.

To rotate platform down:

3. Push in platform lock pin and rotate platform down into standing position.

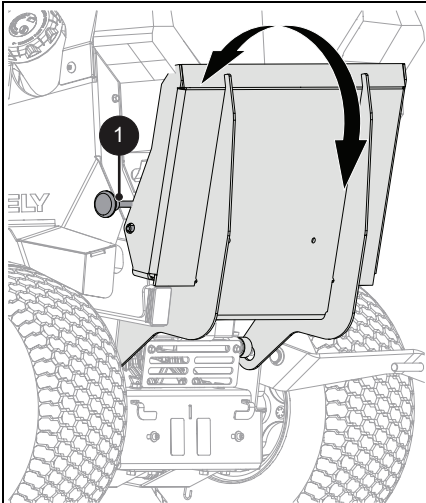

1. Platform Lock Pin

Figure 13

OPERATION



WARNING: AVOID INJURY. Read and understand the Safety section before proceeding.

IMPORTANT: All references to left, right, front or rear are given from the perspective of operator in operator's position, facing the direction of forward travel. Return steering levers to neutral position.

EMERGENCY STOPPING



WARNING: AVOID INJURY. Operating on slopes may lead to loss of steering control. Be prepared to react.

1. Return steering levers to neutral position.
2. Engage parking brake.
3. Push PTO switch down to off position.
4. Turn key to off position and remove from ignition.

START THE ENGINE

1. Move steering levers to neutral position.
2. Engage parking brake.
3. Push PTO switch down to off position.
4. If engine is cold, move choke control lever to the on position. DO NOT use choke on a warm engine.
5. Move throttle control lever to 3/4 fast position.
6. Insert ignition key and turn to the start position. Release key when engine starts.

NOTICE: Do not operate the starter for more than 10 seconds per starting attempt. If the engine does not start, allow a 60-second cool down period between starting attempts.

7. Gradually move choke control lever to the off position after engine starts.

OPERATE UNIT

1. Start the engine. See *Start The Engine* on page 17.
2. Release parking brake.
3. Set throttle control lever to fast position.

IMPORTANT: Engaging the PTO knob with the throttle lever set lower than fast position can cause excessive belt wear. ALWAYS use fast position when engaging the PTO.

4. Pull PTO knob up to on position.

IMPORTANT: Never engage the PTO if the mower is plugged with grass or other material. This may cause damage to the electric clutch.

	<p>WARNING: AVOID INJURY. Move the steering levers slowly and keep the throttle at slow speed until you learn how to operate the unit.</p>
---	---

5. Move steering levers to begin mowing.

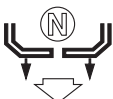
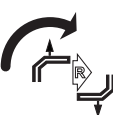
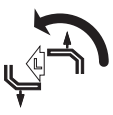
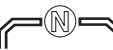
Direction of Travel	Lever Position
Forward	Push both levers forward from neutral position. 
Reverse	Pull both levers backward from neutral position. 
Right Turn	Push left lever farther forward than the right lever. 
Left Turn	Push right lever farther forward than the left lever. 
Stop	Return both levers to neutral position. 

IMPORTANT: Aggressive turning can scuff or damage lawns. Always keep both wheels rotating when making sharp turns. **DO NOT** make turns with inside wheel completely stopped. For minimum turning radius, slowly reverse inside wheel while moving outside wheel slowly forward.

For Best Mowing Results

1. Cut grass when it is dry.
2. Keep mower blades sharp.
3. Keep mower deck properly leveled.
4. Adjust anti-scalp wheels to prevent scalping.
5. Do not set height of cut too low. For very tall grass, mow twice.
6. Do not travel too fast.

7. Mow with engine at full throttle.
8. When mulching, only remove 1/3 of grass length per cutting. Do not cut more than 2.5 cm (1") at a time.
9. Discharge clippings into areas already cut.
10. Change cutting pattern with each mowing.
11. Do not allow grass or debris to collect inside mower deck. Clean after each use.

STOP THE ENGINE

	<p>WARNING: AVOID INJURY. Wait for all moving parts to stop before leaving operator's position.</p>
---	--

1. Move steering levers to the neutral position.
2. Engage parking brake.
3. Reduce throttle to 3/4 fast position.
4. Push PTO switch down to the off position.
5. Move throttle control lever to slow position.
6. Turn key to off position and remove from ignition.

MOVE UNIT MANUALLY

Bypass the transaxles to move the unit with the engine off.

1. Place steering levers in neutral position and engage parking brake.
2. Stop engine, remove key and wait for moving parts to stop and for hot parts to cool.
3. Pull both transaxle bypass levers out into bypass position. See Figure 14.

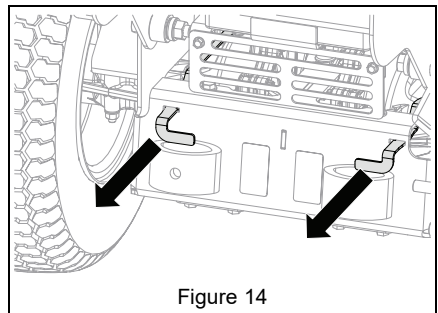

Figure 14

4. Release parking brake and push unit to desired location.
5. Engage parking brake.

6. Push bypass levers into operating position. See Figure 15.

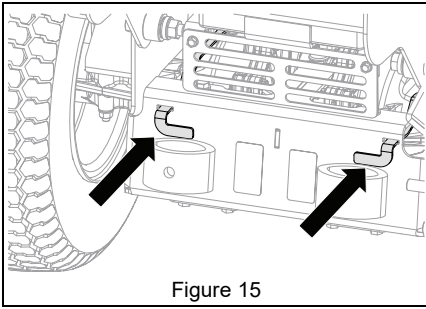

Figure 15

MAINTENANCE



WARNING: AVOID INJURY.
Read and understand the Safety section before proceeding.

Proper maintenance can prolong the life of unit. The *Maintenance Schedule* on page 20 shows the recommended service schedule.

Your Gravelly dealer can provide service and adjustments to keep your unit operating at peak efficiency. Contact an authorized engine manufacturer's service center for engine service.

More frequent service may be required due to working conditions (heavy loads, high ambient temperatures, dusty conditions, or airborne debris).

See the maintenance instructions in the Engine Manual for additional information.

SERVICE POSITION

1. Place unit on a flat, level surface.
2. Stop engine, remove key and wait for moving parts to stop and for hot parts to cool.
3. Chock wheels. Strap and clamp unit onto lift, if used.
4. Place steering levers in neutral position and engage parking brake.
5. Open belt access panel as needed. See Figure 16.

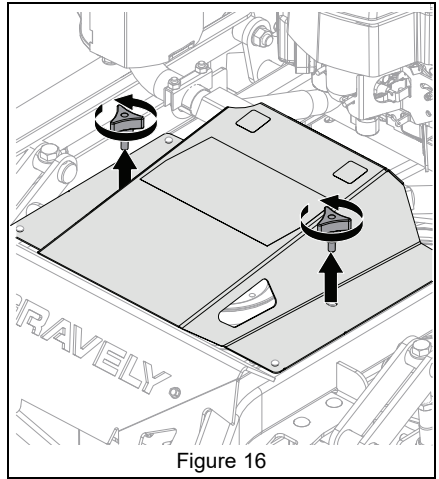

Figure 16

6. Loosen four rear access pad mounting bolts.
7. Pull access pad upward and then rearward to remove. See Figure 17.

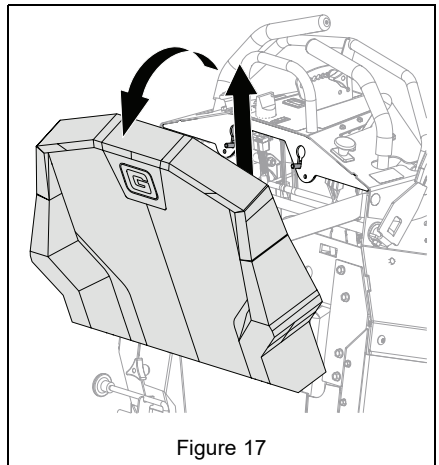

Figure 17

MAINTENANCE SCHEDULE

Service Performed	Each Use	Every 25 hrs.	Every 50 hrs.	Every 100 hrs.	Every 400 hrs.
Clean Engine of any Grass and Debris	•				
Check Engine Oil *					
Change Engine Oil *					
Check Air Filter *					
Change Air Filter *					
Clean Engine Cooling System				•	
Check Safety Interlock System	•				
Check Hydraulic System	•				
Check Tire Pressure	•				
Check Mower Blades		•			
Lubricate Unit			•		
Check Parking Brake	•				
Clean Battery				•	
Check Fasteners				•	
Check Belts				•	
Change Hydraulic Oil and Filter **					•
Lubricate Caster Fork Bearings					•
Lubricate Caster Wheel Bearings					•
* Refer to engine manual for instructions.					
** Change after first 75 hours of operation.					

SERVICE PARTS

See your Gravely dealer to purchase service parts for your unit.

Description	Qty	Part No.
Air Filter	1	21548000
Pre-Cleaner	1	21565800
Engine Oil Filter – Kawasaki	1	21548100
Spark Plug – Kawasaki	2	21536100
Fuel Filter – Kawasaki	1	21548101
Mower Blade – 32"	2	00450200
Mower Blade – 36"	2	00450300
PTO Belt	1	07200831
Spindle Belt – 32"	1	07200833
Spindle Belt – 36"	1	07200832
Transaxle (Hydro) Drive Belt	1	07200835

CHECK SAFETY INTERLOCK SYSTEM

Parking Brake Interlock System

With the parking brake engaged, the steering levers must be locked in neutral.

With the parking brake disengaged, the engine must not start and the engine must shut off if the operator releases the control lever. See *Before Operation* on page 16. If system does not operate correctly, see your dealer for repair. DO NOT operate until repairs are made.

CHECK HYDRAULIC SYSTEM

Check Hydraulic Oil Level

See Figure 18.

1. Place unit in service position and open the rear access panel. See *Service Position* on page 19.
2. Check oil level in expansion tank. Oil should reach the cold fill indicator mark.

IMPORTANT: Engine should be cold when checking initial oil level.

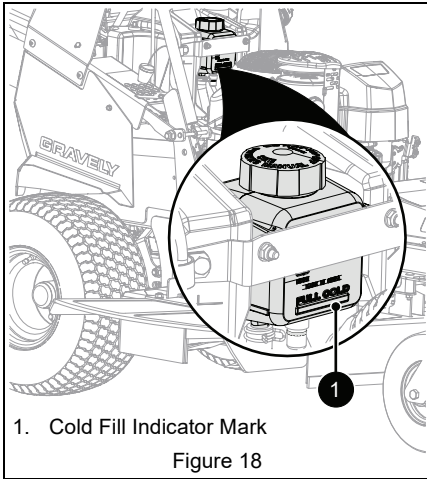

1. Cold Fill Indicator Mark
Figure 18

3. Operate engine for 1 minute and recheck oil levels.
4. Add hydraulic oil, if needed. See *Add Hydraulic Oil* on page 21.

Add Hydraulic Oil

1. Place the unit in service position and open the rear access panel. See *Service Position* on page 19.
2. Remove hydraulic oil expansion tank caps.
3. Fill the expansion tank with 15W-50 synthetic motor oil (Gravelly p/n 00057100) or equivalent until oil reaches the cold fill indicator mark. See Figure 18.
4. Reinstall the expansion tank cap.

Change Hydraulic Oil and Filter

1. Operate unit for a few minutes to warm hydraulic oil.
2. Stop engine, remove key and wait for all moving parts to stop and for hot parts to cool.
3. Lift and properly support rear of unit and remove wheel.
4. Position container under oil filter to catch used oil.

See Figure 19.

5. Remove filter guard and oil filter from transaxle.
6. Remove the drain plug from the fill port and allow transaxle to drain completely.
7. Wipe filter mounting surface clean.
8. Lubricate rubber gasket on new oil filter with clean hydraulic oil.

9. Spin filter onto filter housing until it makes contact, and then turn filter 3/4 turn to tighten.
10. Reinstall filter guard and torque to 0.61 N•m (5.4 lb-in). DO NOT overtighten.
11. Loosen, but do not remove the purge plug.

NOTICE: Loosening the purge plug when adding hydraulic fluid helps air escape and aids in the purging process.

12. Add 15W-50 synthetic motor oil (Gravelly p/n 00057100) or equivalent until oil appears at the bottom of the drain plug (about 1.9L (2 Qt) per transaxle).
13. Reinstall the drain plug and torque to 20.3 N•m (15 lb-ft).
14. Repeat steps 1 – steps 13 for the other transaxle.
15. Purge hydraulic system. See *Purge Hydraulic System* on page 21.

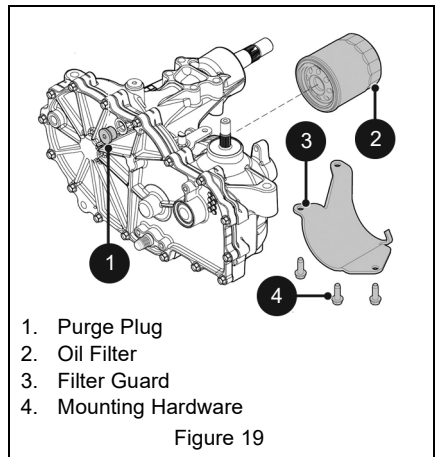

1. Purge Plug
2. Oil Filter
3. Filter Guard
4. Mounting Hardware

Figure 19

Purge Hydraulic System

Purge air from hydraulic system after draining oil or changing the filter.



WARNING: AVOID INJURY. This adjustment requires operating the engine. Use extreme care to avoid contact with moving parts and hot surfaces. Be sure rear of unit is well supported and secure before starting engine.

1. Park unit facing a wall or chock wheels.
2. Release parking brake.

- Support unit so drive wheels are off the ground.
- Bypass transaxles. See *Move Unit Manually* on page 18.
- Start the engine and slowly move steering levers forward and backward 5 or 6 times.
- Return transaxle bypass levers to operating position. See *Move Unit Manually* on page 18.
- Slowly move steering levers forward and backward 5 or 6 times.
- Stop engine, lower unit to ground and check oil level. Add oil if needed.
- Repeat steps 1 – 8 until transaxles operate smoothly in forward and reverse at normal speeds without excessive noise.

CHECK TIRE PRESSURE

See *Specifications* on page 36 for recommended tire pressure.



WARNING: AVOID INJURY.

Explosive separation of tire and rim parts is possible.

- DO NOT inflate tires above the recommended pressure.
- DO NOT inflate tires with a compressor; use a hand pump.
- DO NOT stand in front of tire assembly when inflating. Use a clip-on chuck and extension hose long enough to allow you to stand to one side.
- DO NOT mount a tire without proper equipment and experience.

CHECK MOWER BLADES

Check blades for wear. Replace or sharpen as needed.



CAUTION: AVOID INJURY. Use sturdy gloves or padding to protect hands when working with mower blades. Rotation of one blade rotates the other blades.

Remove Blades

- Place unit in service position. See *Service Position* on page 19.
- Disconnect spark plug wires. See Figure 20.
- Remove hardware retaining blades and lower spindle guards to spindle and remove parts. Retain all parts for reinstallation.
- Clean all grass, dirt and debris from upper and lower spindle guards.

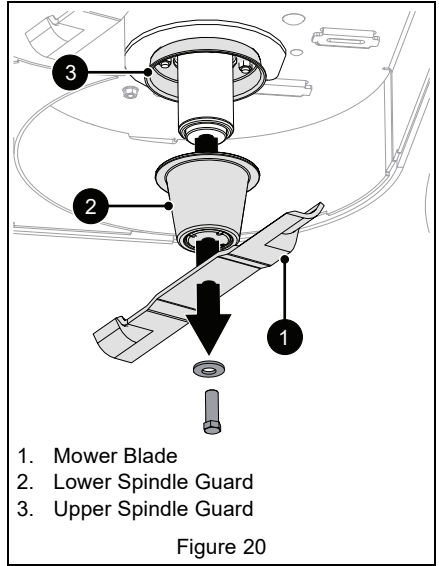

- Mower Blade
- Lower Spindle Guard
- Upper Spindle Guard

Sharpen Blades



CAUTION: DO NOT sharpen blades while attached to unit.

- Remove blades. Discard blades if:
 - More than 1.3 cm (1/2") of metal is removed.
 - Air lifts are eroded.
 - Blades are bent or broken.
- File or grind an equal amount of metal from each cutting edge of the blade until sharp. DO NOT change angle of cutting edge or round the corner of the blade. See Figure 21.

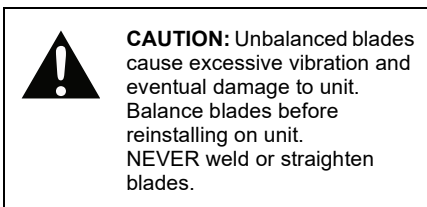
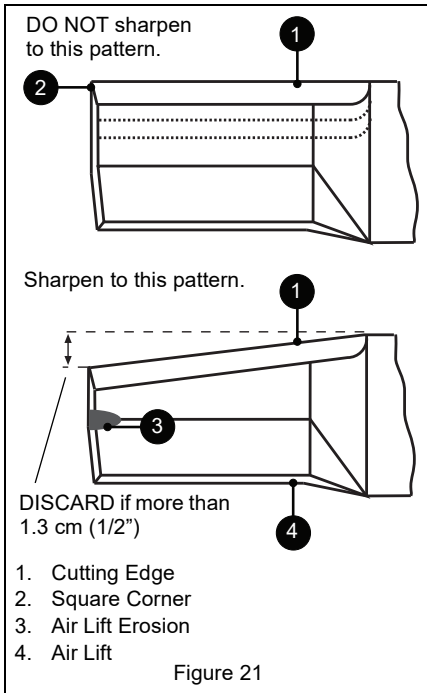

3. Check blade balance by sliding an unthreaded bolt through center hole. Hold the bolt level. If blade does not remain horizontal, sharpen the heavy end until blade is balanced.

Install Blades

See Figure 20.



CAUTION: Mating surfaces between spindle, lower spindle guard, blade and washer **MUST** be free of debris to ensure correct tightness and alignment.

1. Secure lower spindle guards and blades to spindles with one Belleville washer and hex bolt. Torque to 156 N•m – 217 N•m (115 lb-ft – 160 lb-ft).
2. Reconnect spark plug wires.

CHECK PARKING BRAKE

IMPORTANT: Parking brake lever engages drive wheels with two independent cables. It is possible for parking brake to engage one drive wheel only, indicating parking brake cable on opposite side is out of adjustment.

1. Place unit in service position. See *Service Position* on page 19.
2. Bypass transaxles. See *Move Unit Manually* on page 18.
3. Push unit forward.
 - If unit does not move forward, parking brake is functioning correctly.
 - If unit easily moves forward, repair or adjustment is required. See *Adjust Parking Brake* on page 28.
4. Return transaxle bypass levers to operating position. See *Move Unit Manually* on page 18.

CLEAN BATTERY



WARNING: AVOID INJURY. Battery posts, terminals and related accessories contain lead and lead compounds, chemicals known to the State of California to cause cancer and reproductive harm. Wash hands after handling.

Remove Battery

See Figure 22.

1. Rotate platform down into standing position.
2. Remove and retain battery access panel.
3. Disconnect the negative cable and then the positive cable from battery.

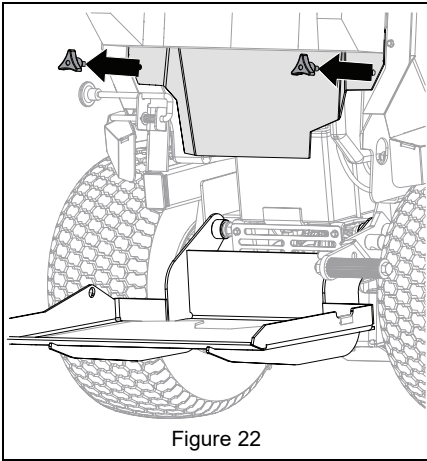
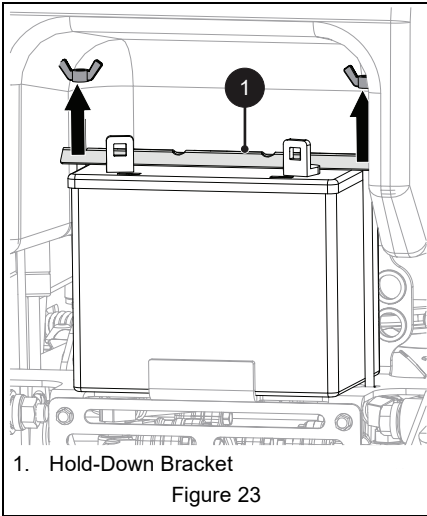

Figure 22

See Figure 23.

4. Remove hold-down bracket.
5. Remove battery.



1. Hold-Down Bracket

Figure 23

Clean Battery

1. Clean terminals and battery cable ends with wire brush.
2. Coat terminals with dielectric grease or petroleum jelly.

Install Battery

1. Install battery.
2. Secure hold-down bracket to battery using original hardware.
3. Reconnect positive cable and then the negative cable.

4. Place boot over positive terminal.
5. Reinstall access panel and secure with wing knobs.

CHARGE BATTERY

NOTICE: DO NOT fast charge. Charging at a higher rate damages or destroys battery. ONLY use an automatic charger designed for use with your battery.

NOTICE: ALWAYS follow information provided on battery by battery manufacturer. Contact battery manufacturer for details regarding charge.

1. Remove battery from unit. See *Remove Battery* on page 23.
2. Place battery on bench or other well-ventilated place.
3. Connect positive lead of charger to positive terminal.
4. Connect negative lead of charger to negative terminal.
5. Charge battery according to charger and battery manufacturers' instructions.
6. Reinstall battery. See *Install Battery* on page 24.

Jump-Starting

Gravely does not recommend jump-starting your unit. Jump-starting can damage engine and electrical system components. See your engine manual for more detailed information.

CHECK FASTENERS

Check for loose hardware and tighten if necessary.

LUBRICATE UNIT

1. Apply oil to all pivot points and pin connections.
2. Pump grease into grease fittings.

Lubricate Caster Fork Bearings

See Figure 24.

1. Place steering levers in neutral position and engage parking brake.
2. Stop engine, remove key and wait for moving parts to stop and for hot parts to cool.
3. Remove dust cap.
4. Pump grease into the fitting until grease appears at the top of the upper bearing.
5. Reinstall dust cap.

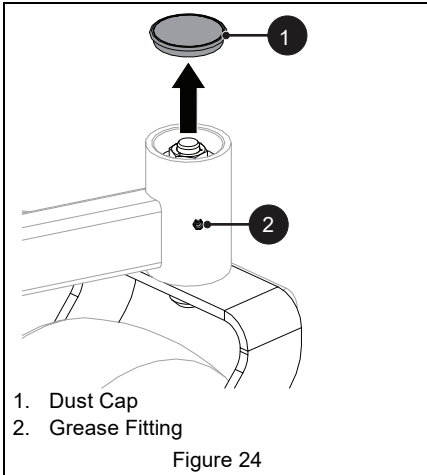

Lubricate Caster Wheel Bearings

1. Place unit in service position. See *Service Position* on page 19.
 2. Support unit so front wheels are off the ground.
 3. Remove wheel from front fork.
- See Figure 25.
4. Remove end caps from wheel hub.
 5. Pump grease into fitting until grease squeezes through the seal in the wheel hub.
 6. Wipe away excess grease.
 7. Reinstall end caps onto wheel hub.
 8. Reinstall wheel into fork and lower unit to ground.

IMPORTANT: After tightening bolt, tire should not have any side-to-side play. Tighten bolt until there is a slight amount of drag on the wheel bearing. The wheel should not spin freely.

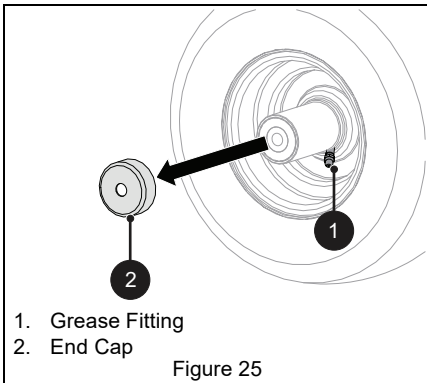

SERVICE AND ADJUSTMENTS



WARNING: AVOID INJURY.
Read and understand the Safety section before proceeding.

ELECTRICAL SERVICE

The fuse/relay panel is located on the right side of the tower accessible from the front.

Replace Fuse

The main fuse is located on the right side of the engine behind the remote starter solenoid. Keep it tucked in this location to protect it from damage.

NOTICE: To avoid damaging the circuit, replace fuses with fuses of the same amperage rating. Determine the cause of electrical failure and repair before replacing failed electrical components.

See Figure 26.

1. Remove defective fuse.
2. Determine cause of fuse failure and repair condition.
3. Install new fuse.

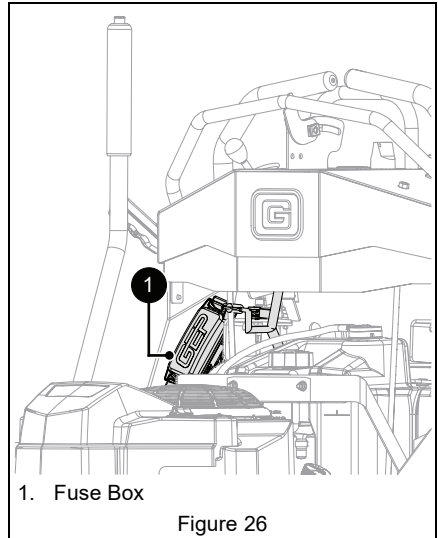

Replace Relay

NOTICE: Relays are interchangeable. Use only quality replacement parts. See *Service Parts* on page 20.

See Figure 27.

1. Remove defective relay.
2. Determine cause of relay failure and repair condition.
3. Install new relay.

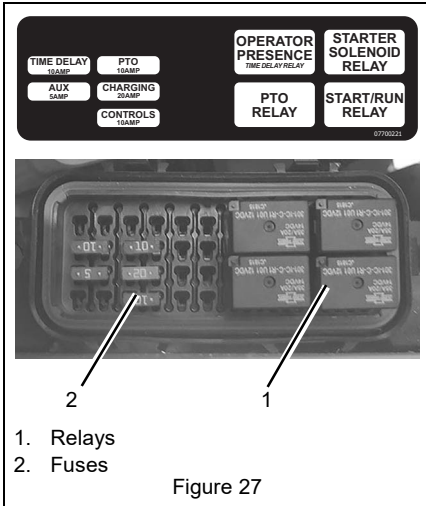

Figure 27

ADJUST TRANSAXLES

Check for Excessive Creep



WARNING: AVOID INJURY. This adjustment requires operating the engine. Use extreme care to avoid contact with moving parts and hot surfaces. Be sure rear of unit is well supported and secure before starting engine.

1. Operate unit for a minimum of 5 minutes to warm hydraulic system.
2. Stop engine and engage parking brake.
3. Chock front wheels and support unit so both drive wheels are off the ground.
4. Remove drive wheels.
5. Start engine, move throttle lever to fast position and release parking brake.
6. Move steering levers forward and backward 5 or 6 times and then return levers to neutral position.
7. Check wheel hubs for rotation.

- If there is only slight rotation, stop engine, reinstall wheels and lower unit to ground.
- If there is excessive rotation, adjust neutral position. See *Adjust Neutral Position* on page 26.

Adjust Neutral Position

If wheel hub has excessive rotation after checking for excessive creep, adjust neutral position.

1. Loosen the return to neutral screw on transaxle. See Figure 28.

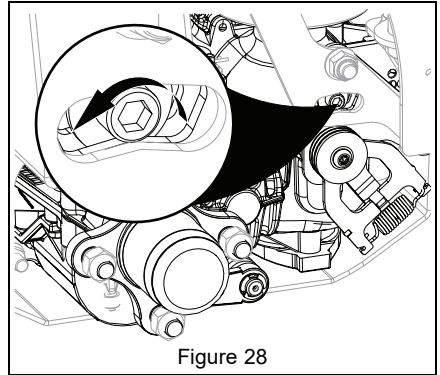

Figure 28

2. Slowly turn transaxle control arm in the opposite direction of hub rotation until hub stops. See Figure 29.

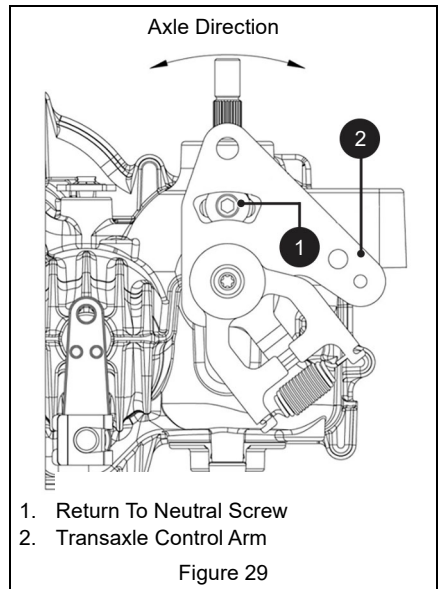

Figure 29

3. Hold the transaxle control arm in position and tighten the return-to-neutral screw.
4. Start engine, move throttle lever to fast position and release parking brake.
5. Move steering levers forward and backward 5 or 6 times and then return levers to neutral position.
6. Check wheels hubs for rotation:
 - If there is only slight rotation, stop engine, reinstall wheels and return unit to operating position.
 - If there is excessive rotation, repeat steps 1 – 5.

ADJUST STEERING LEVERS

See Figures 30, 31.

1. Stop engine, remove key and wait for all moving parts to stop and for hot parts to cool.
2. Engage parking brake.
3. Place rear access panel in the service position. See *Service Position* on page 19.
4. Loosen the eccentric spacer nut.
5. Loosen the jam nuts located on the tie rod.
6. Push and hold a steering control lever forward and turn the control rod until the steering lever makes contact with the front index bar.
7. Repeat step 6 on other side.
8. Return the steering levers to the neutral position.
9. If necessary, slightly adjust the control rods so the steering levers are aligned with each other.
10. Turn tie rod until steering levers align. Adjust both left and right sides as needed.
11. Tighten jam nuts and eccentric spacer nut.

NOTICE: Adjust steering lever interlock if the steering levers are shifted during application of the brake. See *Steering Lever Interlock Adjustment* on page 27.

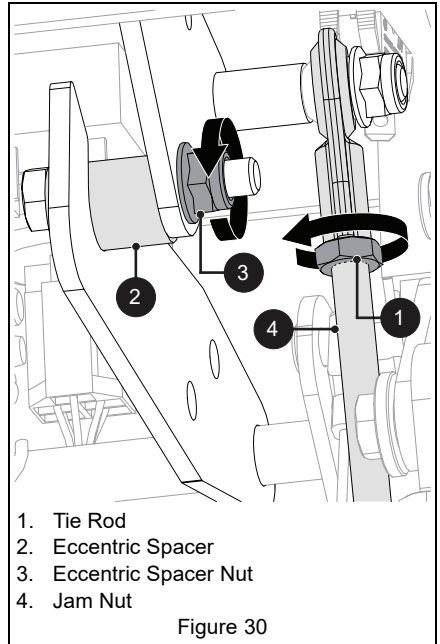

1. Tie Rod
2. Eccentric Spacer
3. Eccentric Spacer Nut
4. Jam Nut

Figure 30

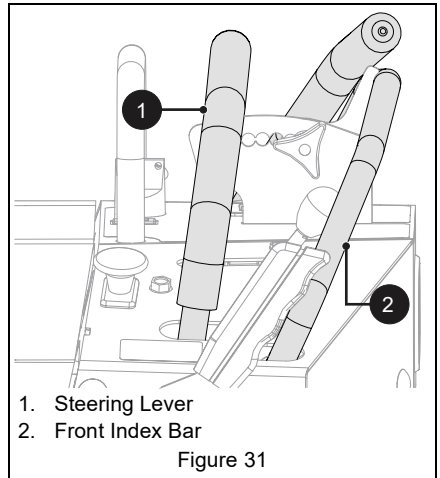

1. Steering Lever
2. Front Index Bar

Figure 31

Steering Lever Interlock Adjustment

See Figure 32.

1. Stop engine, remove key and wait for all moving parts to stop and for hot parts to cool.
2. Chock wheels to prevent unit from rolling.
3. Release parking brake.
4. Loosen but do not remove the outer lock nut on the eccentric brake bushing.

- Engage the parking brake. Bushing will seat in notch in brake lever bracket.
- Tighten lock nut.
- If necessary, adjust steering levers to ensure full alignment with each other.

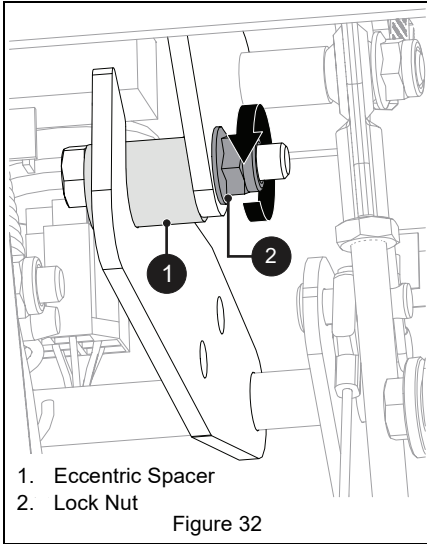

ADJUST UNIT TO DRIVE STRAIGHT

- Park unit on a flat, level surface.
- Check tire pressures. If needed, adjust to recommended pressures. See *Specifications* on page 36.

IMPORTANT: DO NOT inflate tires outside recommended range.

- Drive machine forward, pushing both control levers all the way to index bar.
- Check tracking. If unit does not drive in a straight line, adjust steering levers. See *Adjust Steering Levers* on page 27.

ADJUST PARKING BRAKE

Unit is equipped with two parking brake cables that independently control parking brake on each drive wheel.

- Place unit in service position and open the rear access panel. See *Service Position* on page 19.
- Check parking brake. See *Check Parking Brake* on page 23.
- Disengage parking brake.

See Figure 33.

- Loosen jam nut on parking brake cable adjuster and pull down on adjuster barrel until cable is taut, not tight.
- Thread bottom nut until it contacts bracket.
- Tighten the top jam nut.

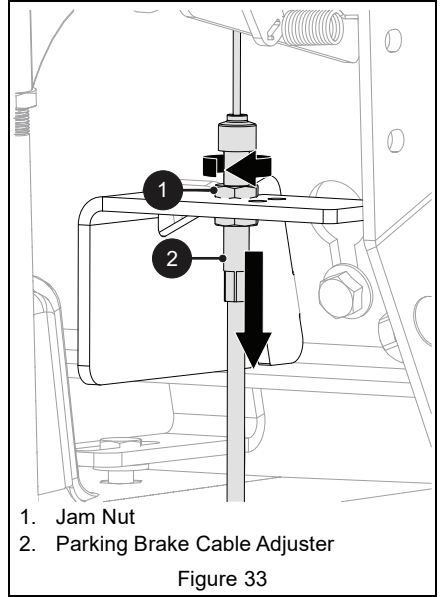

- Engage parking brake and check adjustment. Repeat as needed.
- Ensure bypass levers are in the operating position after brake adjustment.

REPLACE MOWER BELTS



CAUTION: Damaged or worn belts may result in injury and / or damage to the unit. Check belts for excessive wear or cracks often.

Belt Access

- Place steering levers in neutral position and engage parking brake.
- Stop engine, remove key and wait for moving parts to stop and for hot parts to cool.
- Position mower deck at lowest cutting height.
- Lift belt covers to remove from mower deck. See Figure 34.

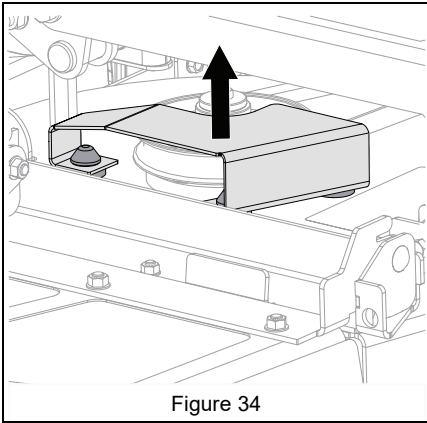

Figure 34

5. Open the belt access panel. See *Service Position* on page 19.

Remove PTO Belt



CAUTION: Use care when releasing idler spring tension. Keep body parts well away from idlers when performing this operation.

See Figure 36.

1. Remove transmission belt. See *Remove Transmission Belt* on page 30.
2. Release tension from idler pulley.
3. Remove PTO mower belt from clutch and then from jackshaft.

Install PTO Belt

1. Install PTO belt on clutch and then on jackshaft. See Figure 36.

IMPORTANT: Ensure that correct sheave is used based on deck height setup:

See Figure 35.

- Low (38 mm – 102 mm or 1.5" – 4") position: Use top sheave.
- High (64 mm – 127 mm or 2.5" – 5") position: Use middle sheave.

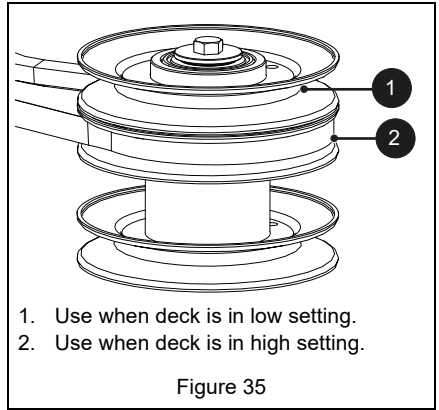

Figure 35

1. Use when deck is in low setting.
2. Use when deck is in high setting.

2. Reinstall transmission belt. See *Install Transmission Belt* on page 30.
3. Verify that there are no twists in belts and that they are routed correctly.
4. Replace belt guards and close belt access panel.

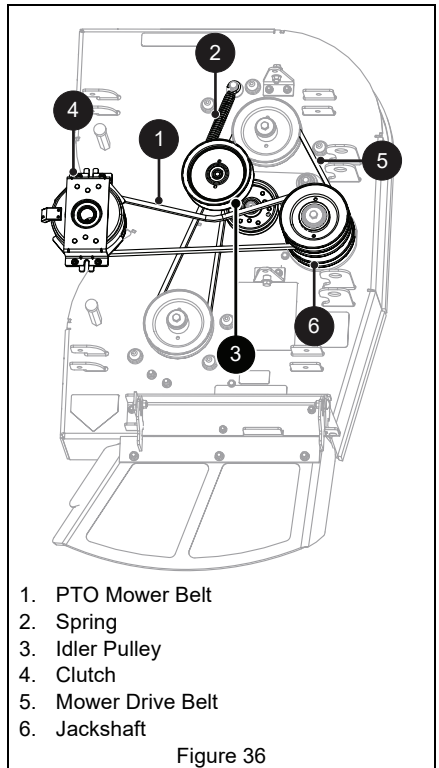

Figure 36

1. PTO Mower Belt
2. Spring
3. Idler Pulley
4. Clutch
5. Mower Drive Belt
6. Jackshaft

Remove Mower Drive Belt

See Figure 36.

1. Remove PTO belt from jackshaft. See *Remove PTO Belt* on page 29.
2. Relieve spring tension and remove spring from bracket.
3. Remove mower drive belt.

Install Mower Drive Belt

See Figure 36.

1. Install mower drive belt.
2. Verify that there are no twists in belts and that they are routed correctly.
3. Reinstall spring to bracket.
4. Reinstall PTO belt. See *Install PTO Belt* on page 29.

Remove Transmission Belt

1. Pull back idler arm and remove transmission belt. See Figure 37.

Install Transmission Belt

See Figure 37.

1. Install new transmission belt.
2. Verify that there are no twists in belts and that they are routed correctly.

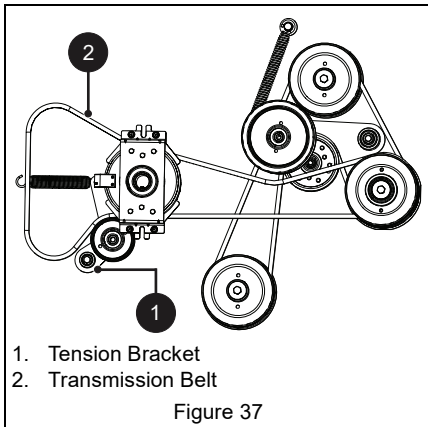

REMOVE / INSTALL MOWER DECK

Remove Deck

1. Place unit in service position. See *Service Position* on page 19.



WARNING: AVOID INJURY!
Springs store energy. Keep body parts well away from pinch points when removing the deck.

2. Remove PTO belt from clutch. See *Remove PTO Belt* on page 29.



WARNING: AVOID INJURY.
Mower lift arms and lift pedal could cause severe injury if the lift-assist springs are not disconnected before the lift links.

NOTICE: Position supports such as blocks or jack stands under each side of the deck.

3. Slowly lower deck until it rests on supports.
4. Remove hardware securing mower lift links to the deck. See Figure 38.

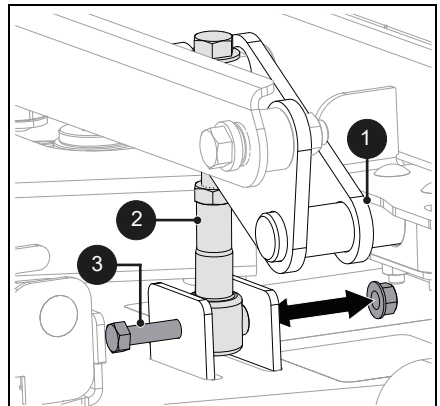

5. Remove and retain drag link hardware. See Figure 39.
6. Slide deck out from under unit.

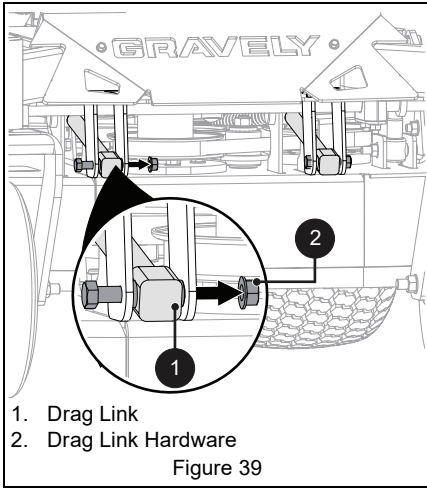

Install Deck

1. Position deck under unit.
2. Reinstall front drag links to deck with original mounting pins and hardware.
3. Position the deck in the correct HOC range. See *Adjust Deck Height* on page 32.
4. Reinstall lift links using original hardware.
5. Install PTO belt. See *Install PTO Belt* on page 29.
6. Level the deck. See *Level And Pitch Mower Deck* on page 31.

LEVEL AND PITCH MOWER DECK

IMPORTANT: Make sure unit is on a flat, level surface and that tires are inflated to the recommended pressures.

Check Blade Level and Pitch

1. Place steering levers in neutral position and engage parking brake.
2. Stop engine, remove key and wait for moving parts to stop and for hot parts to cool.
3. Raise mower deck to a 95.3 mm (3.75") cutting height if belt is in high HOC range and 70 mm (2.75") if belt is in low HOC range.
4. Place blocks at each corner of the deck to support the weight of the deck.

NOTICE: Place blocks under the bottom edge of the deck, not under the reinforcement bar welded along deck face.

See Figure 40.

5. Position mower blades so ends point left to right across the width of the deck.
6. Measure the distance between the ground and cutting edge of the left blade and right blades. Distances should be within 4.7 mm (3/16").

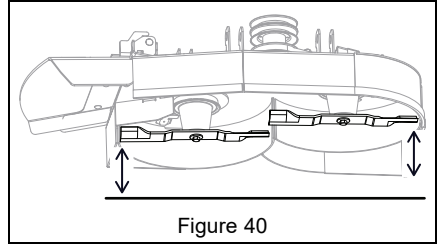

See Figure 41.

7. Position mower blades so ends point front to back and measure the following:
 - At the front of the deck, measure the distance between the ground and the cutting edge of the middle blade.
 - At the rear of the deck, measure the distance between the ground and the cutting edge of the left and the right blades.
8. The cutting edge at the front of the deck should be 3.2 mm (1/8") lower than the cutting edges at the rear of the deck.

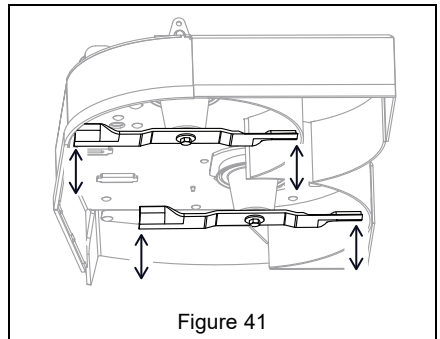

If measurements are out of range, raise the low side of the deck using the height adjusters on the deck lift brackets.

Adjust Blade Height

See Figure 42.

Level and pitch the mower with the height adjusters on each deck lift bracket.

1. Loosen the jam nut on the deck leveling bracket bolt about 1/4 turn to reduce clamp load on the height adjusters.
2. Loosen the jam nut on the deck lift bolt and then turn the bolt clockwise to raise the deck or counterclockwise to lower the deck.
3. Tighten jam nuts.

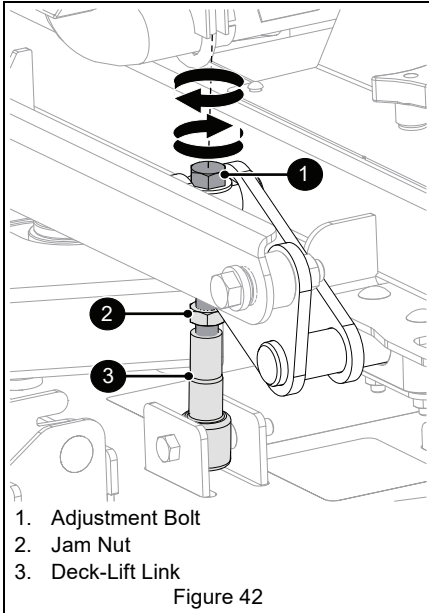

Adjust Deck Height

The mower deck has two height options to extend the height-of-cut range.

- Low position: 38 mm – 102 mm (1.5" – 4")
- High position: 64 mm – 127 mm (2.5" – 5")

To change deck height:

1. Follow procedure for removing deck. See *Remove Deck* on page 30.

NOTICE: Deck does not have to be slid out from under unit.

2. Choose the mounting holes for the desired cut height.

See Figures 43, 44 and 45.



CAUTION: DO NOT engage mower blades in the transport lock position if the deck is in the low HOC range (1.5" – 4"). Belt damage may occur.

- For higher height of cut, mount the deck idler leveling bracket and HOC selection in the lower holes. Install V-belt onto the lower pulley of double pulley.
- For lower height of cut, mount the deck idler leveling bracket and HOC selection in the upper holes. Install V-belt onto the upper pulley of double pulley.

IMPORTANT: Ensure all HOC positions match the corresponding HOC range.

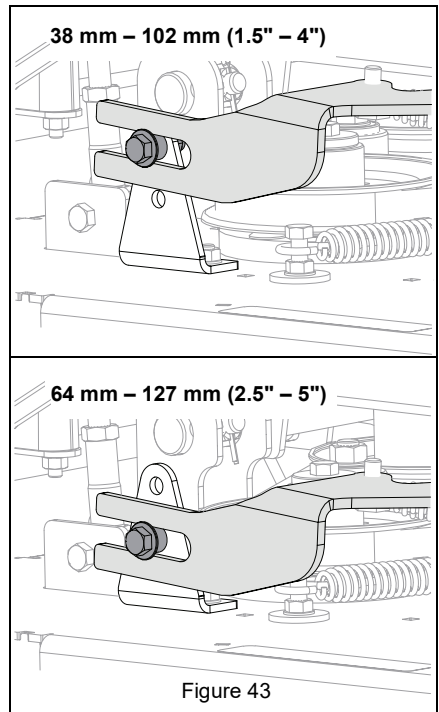

64 mm – 127 mm (2.5" – 5")

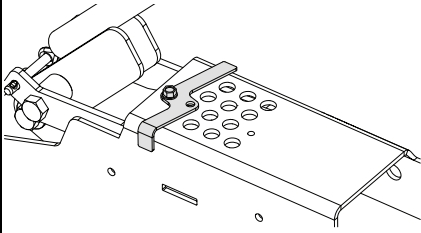

38 mm – 102 mm (1.5" – 4")

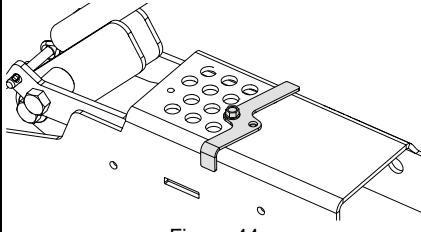

Figure 44

REVERSE CLUTCH BRAKE PLATES

See Figure 46.

1. Remove hardware securing brake plates to clutch bracket. Retain for reinstallation.
2. Reverse the brake plates and secure to clutch bracket using original hardware.

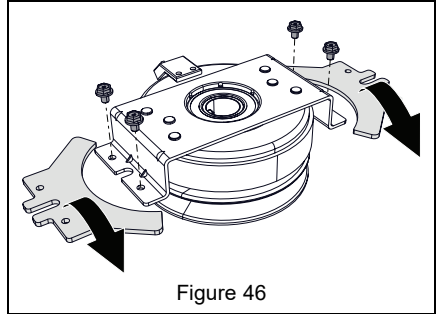
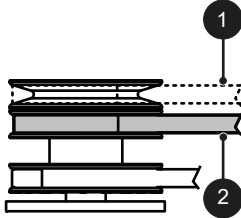

Figure 46

BELT POSITION



1. 38 mm – 102 mm (1.5" – 4")
2. 64 mm – 127 mm (2.5" – 5")

Figure 45

3. Follow procedure for installing deck. See *Install Deck* on page 31.

TROUBLESHOOTING

Problem	Probable Cause	Correction
Engine does not crank.	PTO engaged.	Disengage PTO.
	Parking brake disengaged.	Engage parking brake.
	Loose or corroded battery cables.	Clean and tighten battery cables. See <i>Clean Battery</i> on page 24.
	Discharged battery.	Charge battery. See <i>Charge Battery</i> on page 24.
	Faulty starter.	See your Gravely Dealer.
	Blown fuse.	Check main fuse and replace if necessary.
	Failed relay.	Check relays in fuse block and replace if necessary
	Loose or broken wires.	Check wire harness and connections.
	Weak battery.	Check voltage and charge if required. See <i>Charge Battery</i> on page 24.
Engine cranks but does not start.	Fuel tank empty.	Fill fuel tank. See <i>Before Operation</i> on page 16.
	Faulty spark plug.	Replace spark plug. Refer to Engine Manual.
	Air cleaner is plugged or dirty.	Clean or replace air cleaner. Refer to Engine Manual.
	Fuel filter is dirty.	Clean or replace fuel filter. Refer to Engine Manual.
	Faulty engine.	Refer to Engine Manual or see your Gravely Dealer.
	Weak battery.	Check voltage and charge if required. See <i>Charge Battery</i> on page 24.
Oil pressure light is on.	Oil pressure is low.	Refer to Engine Manual.
Engine continues to run when ignition key is in the off position.	Ignition ground wire disconnected.	Connect ground wire to clean metal surface.
	Ignition switch failure.	Replace ignition switch. See your Gravely Dealer.
PTO or mower blades do not engage or shut off.	Operator presence switch not depressed.	Depress operator presence switch by holding down right steering control handle.
	Faulty PTO switch.	Check the electrical system to the clutch for damage or wear. See your Gravely Dealer.
Unit does not drive.	Parking brake engaged.	Disengage parking brake.
	Transmission bypass levers open.	Close transmission bypass levers. See <i>Move Unit Manually</i> on page 18.
	Hydraulic oil level low.	Add hydraulic oil. See <i>Check Hydraulic Oil Level</i> on page 20.
	Faulty hydraulic drive system.	See your Gravely dealer.
Blades do not stop within 7 seconds.	Clutch brake plates worn.	Reverse clutch brake plates. See <i>Reverse Clutch Brake Plates</i> on page 33. If clutch brake plates have already been reversed, replace clutch.

STORAGE



WARNING: AVOID INJURY.
Read and understand entire *Safety* section before proceeding.

SHORT-TERM STORAGE

IMPORTANT: NEVER wash unit with high-pressure water or store outdoors.

1. Allow unit to cool and clean with mild soap and water.
2. Tighten all hardware to correct specifications.
3. Inspect unit for visible signs of wear or damage. Repair as needed.
4. Prepare fuel system for storage.

NOTICE: Gravelly recommends using a quality fuel stabilizer in all fuel. Gasoline left in the fuel system without a stabilizer, even for short periods of time, deteriorates and leaves gummy deposits in the system that may damage the carburetor and fuel hoses, filter and tank. For the best effectiveness, add stabilizer to all fuel containers whenever purchasing fuel. Add the stabilizer to the container before adding fuel.

- a. Add Gravelly fuel stabilizer (see Service Parts on page 21) or equivalent according to manufacturer's instructions to the fuel tank and any fuel containers with remaining fuel.
 - b. Operate engine outdoors for at least 5 minutes to allow stabilizer to reach the carburetor.
5. Turn key to off position and remove from ignition.
 6. Store unit in a cool, dry, protected area. DO NOT store unit outdoors.

LONG-TERM STORAGE

1. Perform short-term storage procedures.
2. Lubricate as directed in *Maintenance Schedule* on page 20.
3. Touch-up all scratched painted surfaces.
4. Remove and charge battery as directed in *Charge Battery* on page 24. Store battery in a cool, dry, protected area.
5. Store unit in a cool, dry, protected area. Do not store unit outdoors.

START-OF-SEASON PREPARATION

1. Before adding fuel for the first time after long-term storage, add fresh, stabilizer-treated fuel to fuel tank and any fuel containers with remaining fuel.
2. Charge and install the battery.

ACCESSORIES

See your authorized Gravelly dealer to add these optional accessories to your unit.

Description	Part No.
Mulch Kit – 32"	79403200
Mulch Kit – 36"	79403300
Operator-Controlled Discharge Chute Kit	79403400
Grass Catcher Kit *	78804300
Light Kit – 32"	79402800
Trimmer Mount Kit	79403800
Pack Blower Mounting Kit	79403900
Bucket Mounting Kit	79404000

* Remove discharge chute bracket for operation with grass catcher. Reinstall chute bracket for operation without grass catcher. See Figure 47.

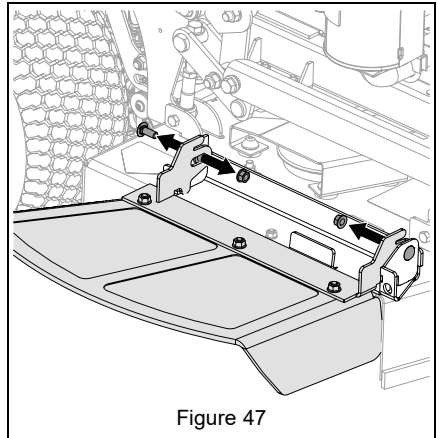

Figure 47

SPECIFICATIONS

Model Number	994149	994157
Model	Pro-Stance 36	Pro-Stance 32
Engine	Kawasaki FS600	
Displacement – cm ³ (in ³)	603 (36.8)	
High Idle - RPM (Min.)	3600 ± 100	
Liquid or Air Cooled	Air	
Speed		
Forward Maximum – km/h (mph)	12.9 (8)	
Reverse Maximum – km/h (mph)	4.8 (3)	
Turning Radius	Zero	
Electrical		
Starter	Electric	
Battery	12V-U1 Minimum 300 CCA	
Power Take-Off	Electric PTO Clutch/Brake	
Fuel		
Fuel Type	Refer to engine manual.	
Tank Capacity – L (gal.)	22.7 (6)	
Transmission		
Type	Hydrostatic Drive	
Transmission Oil	Use 15W-50 synthetic motor oil (Gravely p/n 00057100) or equivalent	
Hydraulic Oil Filter	Yes	
Size and Weight		
Length – cm (in.) With Operator Platform Raised With Operator Platform Lowered	160 (63.0) 187.5 (73.8)	
Width – cm (in.) Discharge Chute Raised: Discharge Chute Lowered:	92.7 (36.25) 121.9 (48)	83.8 (33.0) 113 (44.5)
Weight – kg (lb)	345 (760)	341 (750)
Tires		
Front Tire Size – in.	11 x 4.00 – 5 (Semi-pneumatic)	
Rear Tire Size – in.	18 x 8.5 – 8	18 x 6.5 – 8
Rear Tire Pressure – kPa (psi)	83 – 103 (12 – 15)	
Mower Deck		
Cutting Width – cm (in.)	91.4 (36)	81.3 (32)
Cutting Height – cm (in.) Low Position High Position (Factory shipping position)	38 – 102 (1.5 – 4) 64 – 127 (2.5 – 5)	
Cutting Height Increments – cm (in.)	0.64 (0.25)	



GRAVELY

Outdoor Power Equipment Limited Warranty

AriensCo warrants to the original purchaser that Gravely brand products purchased on or after 9/1/2019 will be free from defects in material and workmanship for the time period noted in the chart below.

If any product is rented or leased, then the duration of these warranties shall be 90 days after the date of purchase.

An authorized Gravely dealer will repair any defect in material or workmanship, and repair or replace any defective part, subject to the conditions, limitations and exclusions set forth herein. Such repair or replacement will be free of charge (labor and parts) to the original purchaser; except as noted below. Pick-up and delivery are at the owner's expense.

The warranty code is found on the model and serial number identification label on the unit.

Warranty Code	Product Group	Warranty Period
AA	Serialized Attachments	1 Year.
AB	Serialized Attachments	2 Years.
CH	Pro-Turn Z and Pro-Turn ZX Mowers	4 Years or 750 Hours.*
CJ	Pro-QXT	4 Years or 500 Hours.*
CK	Compact-Pro and Pro-Walk Hydro Mowers	4 Years or 750 Hours.* No Hour Limit for First 2 Years.
CL	Pro-Turn 100 and Pro-Stance Mowers	5 Years or 1000 Hours.* No Hour Limit for First 2 Years.
CM	Pro-Turn 200 Mowers	5 Years or 1250 Hours.* No Hour Limit for First 2 Years.
CN	Pro-Turn 400 Mowers	5 Years or 1500 Hours.* No Hour Limit for First 2 Years.
CO	Pro-Walk Gear Mowers	2 Years.
HF	ZT-X Mowers	3 Years or 300 Hours.*
HG	ZT-XL Mowers	4 Years or 400 Hours.*
HH	ZT-HD Mowers	4 Years or 500 Hours.*
UG	Atlas JSV	1 Year.

* Whichever comes first.

Special Extensions

The chart below details special **extensions** to warranty terms. Warranty terms are total time periods covered. If any product is rented or leased, there are no extensions to the 90-day warranty.

Warranty Code	Warranty Term Extension	Warranty Period	Detail
CL, CM, CN, CO	Mower Deck Shell and Main Frame	Lifetime Limited.	Warranty is for parts only after the initial warranty period. Components are covered for manufacturer's defect only, not wear.

Exclusions and Limitations

The charts below detail special **exclusions and limitations** to this warranty.

Warranty Term Exclusions	Warranty Period
Air filters, brake arms, brake linings, brake shoes, brushes, cutters, fuel filters, headlights, knives, light bulbs, lubricants, mower blades, oil, oil filters, spark plugs, scraper blades, shear bolts, skid shoes and spoon tines.	Components are not covered under warranty.

Hydro-Gear Transaxle Limitation
See Hydro-Gear warranty. The warranty is administrated by AriensCo. Refer to www.gravely.com for warranty statement.

Warranty Term Limitations	Warranty Period
Cloth, Plastic and Rubber Components. Mufflers, Tires and Belts.	Components are covered for manufacturer's defect only, not wear.

Exclusions – Items Not Covered by This Warranty

- Parts that are not genuine Gravely service parts are not covered by this warranty and may void the warranty if the parts result in premature wear or damage to the product.
- Damages resulting from the installation or use of any part, accessory, or attachment which is not approved by the AriensCo for use with product(s) identified herein are not covered by this warranty.
- Any misuse, alteration, improper assembly, improper adjustment, neglect, or accident which requires repair is not covered by this warranty.
- Repairs or adjustments required due to failure to use fresh fuel or failure to properly prepare the unit for periods of non-use.
- **Use of gasoline blends exceeding 10% ethanol voids any and all warranties.**
- **Any tampering with the hour meter voids any and all warranties.**
- Products are designed to the specifications in the area that the product was originally distributed. Different areas may have significantly different legal and design requirements. This warranty is limited to the requirements in the area in which the unit was originally distributed. AriensCo does not warrant this product to the requirements of any other area. Warranty service is limited to service within the area originally distributed.
- In countries other than the United States and Canada, contact the AriensCo dealer for warranty policies that govern within your country. Rights may vary from country to country and within any one country.

Evaporative Emissions Control Warranty Exception

As required by the California Air Resources Board (CARB) and the US Environmental Protection Agency (EPA) the evaporative emissions control system is warranted to the ultimate purchaser, and any subsequent owner, for two years.

The CARB and EPA evaporative emissions control system warranty is described in a separate evaporative emission control warranty statement.

Special Exclusions for Job-site Vehicles

The following uses void the warranty terms on Atlas JSV (Warranty Code UG) vehicles:

- Renting or leasing the vehicle.
- Using the vehicle to tow or carry loads in excess of the limits specified in the operator's manual.
- Modifying the vehicle with parts and accessories that are not genuine or authorized Gravelly parts or accessories.
- Modifying the vehicle without express written authorization from Gravelly.
- Operating the vehicle when it has not been completely and properly assembled and pre-delivered by an authorized Gravelly dealer.

Battery Warranty

Battery warranty is one year. Units used for rental or lease have no exceptions to the 90-day warranty. Total battery claim reimbursement will not exceed 45.00 USD.

Engines

The chart below details engine warranty information. Engine warranty terms may vary from the specific terms of this warranty. If inconsistent, the terms of the engine warranty shall apply to the engine and its component parts.

Engine Manufacturer	Detail	
Gravelly V-Twin	Serial Number 0000400 and lower	4 Years or 500 Hours, whichever comes first. Refer to www.gravelly.com for warranty statement.
	Serial Number 0000401 and higher	4 Years or 750 Hours, whichever comes first. Refer to www.gravelly.com for warranty statement.
Yamaha	Yamaha-branded engines are warranted by the manufacturer and the warranty is administrated by AriensCo. Refer to www.gravelly.com for warranty statement.	
Briggs & Stratton, Kawasaki, Kohler	Covered by the engine manufacturer's warranty. Refer to the engine manufacturer's warranty statements.	

Parts and Accessories

Service replacement parts and non-serialized accessories are warranted for 90 days from date of purchase. Parts and accessories must be installed by an authorized Gravelly dealer to be covered. Labor is not included.

Customer Responsibilities

Register the product immediately at the time of sale. If the dealer does not register the product, the customer must register the unit on-line at www.gravelly.com.

To obtain warranty service, the **original purchaser** must:

- Ensure that the maintenance and adjustments explained in the Operator's Manual are routinely completed.
- Promptly notify AriensCo or an authorized Gravelly service representative of the need for warranty service.
- Transport the product to and from the place of warranty service at owner's expense.
- Have the warranty service performed by an authorized Gravelly service representative.

To find an authorized dealer use the dealer locator on our websites, or contact us by mail or phone.

Globally except Australia or New Zealand:	Australia:	New Zealand:
AriensCo 655 W. Ryan Street Brillion, WI 54110 Phone: (920) 756 - 4688 www.gravelly.com	Masport Australia Pty Ltd 27 Commercial Drive Dandenong South Victoria 3175 Australia Phone: 1300 366 225 www.masport.com.au	Masport Ltd 1-37 Mt. Wellington Highway, Panmure, Auckland 1060 New Zealand Phone: 0800 627 7678 www.masport.co.nz

Disclaimer

AriensCo may from time to time change the design of its products. Nothing contained in this warranty shall be construed as obligating the AriensCo to incorporate such design changes into previously manufactured products, nor shall such changes be construed as an admission that previous designs were defective.

Limitation of Remedy and Damages

AriensCo liability under this warranty, and under any implied warranty that may exist, is limited to repair of any defect in workmanship, and repair or replacement of any defective part. AriensCo shall not be liable for incidental, special, or consequential damages (including lost profits). Some states do not allow the exclusion of incidental or consequential damages, so the above limitation or exclusion may not apply to you.

Australian Consumer Law

The following applies solely to warranties subject to Subsection 102(1) of the Australian Consumer Law: Our goods come with guarantees that cannot be excluded by the Australian Consumer Law. You are entitled to a replacement or refund for a major failure and for compensation for any other reasonably foreseeable loss or damage. You are also entitled to have the goods repaired or replaced if the goods fail to be of acceptable quality and failure does not amount to a major failure.

Disclaimer of Further Warranty

AriensCo makes no warranty, express or implied, other than what is expressly made in this warranty. If the law of your state provides that an implied warranty of merchantability, or an implied warranty of fitness for particular purpose, or any other implied warranty, applies to AriensCo then any such implied warranty is limited to the duration of this warranty. Some states do not allow limitations on how long an implied warranty lasts, so the above limitation may not apply to you.

This warranty gives you specific legal rights, and you may also have other rights which vary from region to region.



GRAVELLY

655 West Ryan Street
Brillion, WI 54110

www.gravelly.com

WARNING

The engine exhaust from this product contains chemicals known to the State of California to cause cancer, birth defects and other reproductive harm.

ARIENS | CO

