



THE KING OF SNOW®

921 Series Sno-Thro®

Owner/Operator Manual

Manuel Du Propriétaire/Utilisateur

Models

- 921013 – Deluxe 30**
(Serial No. 35000 and up)
- 921017 – Deluxe 24 Platinum**
(Serial No. 35000 and up)
- 921018 – Deluxe 30 Platinum**
(Serial No. 35000 and up)
- 921022 – Deluxe 28**
(Serial No. 35000 and up)
- 921023 – Deluxe Track 28**
(Serial No. 35000 and up)
- 921031 – Deluxe 24**
(Serial No. 101 and up)

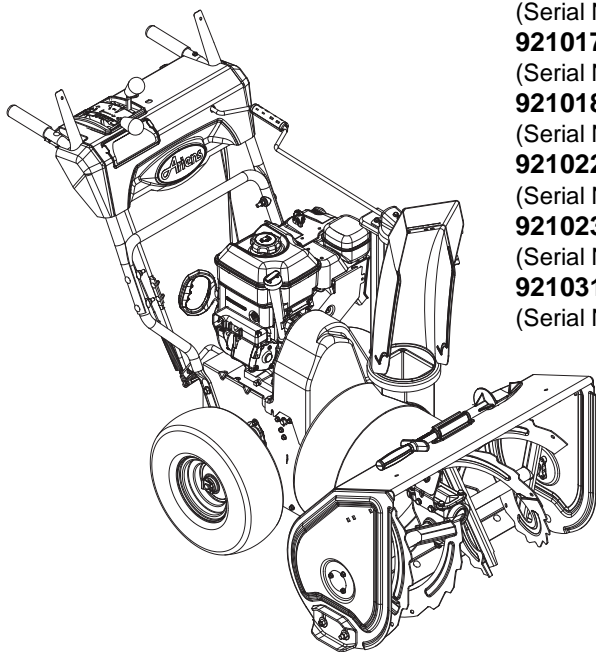

Gasoline containing up to 10% ethanol (E10) or up to 10% MTBE (methyl tertiary butyl ether) is acceptable for use in this machine. The use of any gasoline exceeding 10% ethanol (E10) or 10% MTBE will void the product warranty.

Il est possible d'utiliser de l'essence contenant jusqu'à 10% d'éthanol (E10) ou 10% de MTBE (éther méthyl-tertiobutylque) sur cette machine. L'utilisation d'une essence contenant plus de 10% d'éthanol (E10) ou de 10% de MTBE annulent la garantie.



GB ENGLISH

F FRANÇAIS

04335900D 11/11
Printed in USA

TABLE OF CONTENTS

SAFETY.....	4	STORAGE.....	36
ASSEMBLY.....	8	SERVICE PARTS.....	36
CONTROLS and FEATURES.....	16	ACCESSORIES.....	36
OPERATION.....	18	TROUBLESHOOTING.....	37
MAINTENANCE.....	24	SPECIFICATIONS.....	38
SERVICE AND ADJUSTMENTS.....	27	WARRANTY.....	40

INTRODUCTION

NON-ENGLISH MANUALS



Manuals in languages other than English may be obtained from your Dealer. Visit your dealer or www.ariens.com for a list of languages available for your equipment.



Manuals printed in languages other than English are also available as a free download on our website:

<http://www.ariens.com>

MANUALES EN IDIOMAS DIFERENTES DEL INGLÉS



Puede obtener manuales en idiomas diferentes del inglés en su distribuidor. Visite a su distribuidor o vaya a www.ariens.com para obtener una lista de idiomas disponibles para su equipo.



También puede imprimir manuales en idiomas diferentes del inglés descargándolos gratuitamente de nuestra página Web:

<http://www.ariens.com>

MANUELS NON ANGLAIS



Des manuels dans différentes langues sont disponibles chez votre revendeur. Rendez-vous chez votre revendeur ou allez sur le site www.ariens.com pour consulter la liste des langues disponibles pour votre équipement.



Les manuels imprimés dans des langues différentes de l'anglais sont également disponibles en téléchargement gratuit sur notre site Web:

<http://www.ariens.com>

MANUALS

Before operation of unit, carefully and completely read your manuals. If used improperly, this unit could be dangerous and cause personal injury or property damage. The contents will provide you with safety instructions for the safe use of your unit during normal operation and maintenance.

All reference to left, right, front, or rear are given from operator standing in operation position and facing the direction of forward travel.

ENGINE MANUAL

The engine on this unit is covered by a separate manual specific to the engine. This manual is included in the literature package that shipped with the unit. Refer to this manual for engine service recommendations. If the engine manual is not available, contact the engine manufacturer for a replacement manual.

MODEL AND SERIAL NUMBERS

When ordering replacement parts or making service inquiries, know the Model and Serial numbers of your unit and engine.

Numbers are located on the product registration form in the unit literature package. They are printed on a serial number label, located on the frame of your unit.

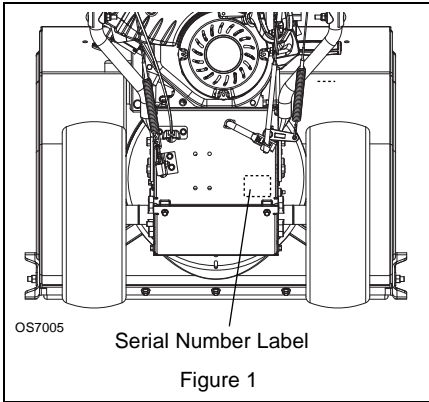

- Record Unit Model and Serial numbers here.

- Record Engine Model and Serial numbers here.

PRODUCT REGISTRATION

The Ariens dealer must register the product at the time of purchase. Registering the product will help the company process warranty claims or contact you with the latest service information. All claims meeting requirements during the limited warranty period will be honored, whether or not the product registration card is returned. Keep a proof of purchase if you do not register your unit.

Customer Note: If the dealer does not register your product, please fill out, sign, and return the product registration card to Ariens or go to www.ariens.com.

UNAUTHORIZED REPLACEMENT PARTS

Use only Ariens replacement parts. The replacement of any part on this vehicle with anything other than an Ariens authorized replacement part may adversely affect the performance, durability, or safety of this unit and may void the warranty. Ariens disclaims liability for any claims or damages, whether warranty, property damage, personal injury or death arising out of the use of unauthorized replacement parts. To locate your nearest Ariens Dealer, go to www.ariens.com on the Internet.

DISCLAIMER

Ariens reserves the right to discontinue, make changes to, and add improvements upon its products at any time without public notice or obligation. The descriptions and specifications contained in this manual were in effect at printing. Equipment described within this manual may be optional. Some illustrations may not be applicable to your unit.

DELIVERY

Customer Note: If you have purchased this product without complete assembly and instruction by your retailer, it is your responsibility to:

1. Read and understand all assembly instructions in this manual. If you do not understand or have difficulty following the instructions, contact your nearest Ariens Dealer for assistance. Make sure all assembly has been properly completed.

NOTE: To locate your nearest Ariens Dealer, go to www.ariens.com on the Internet.



WARNING: Improper assembly or adjustments can cause serious injury.

2. Understand all Safety Precautions provided in the manuals.
3. Review control functions and operation of the unit. Do not operate the Sno-Thru unless all controls function as described in this manual.
4. Review recommended lubrication, maintenance and adjustments.
5. Review Limited Warranty Policy.
6. Fill out a Product Registration Card and return the card to the Ariens Company or go to www.ariens.com.

SAFETY



WARNING: To avoid injury to hands and feet, always disengage clutches, shut off engine, and wait for all movement to stop before unclogging or working on snow thrower.

Hand contact with the rotating impeller is the most common cause of injury associated with snow throwers. Never use your hand to clean out the discharge chute.

Keep hands and feet away from auger and impeller.

SAFETY ALERTS



Look for these symbols to point out important safety precautions. They mean:

Attention!



Personal Safety Is Involved!

Become Alert!

Obey The Message!

The safety alert symbols above and signal words below are used on decals and in this manual. Read and understand all safety messages.



DANGER: IMMINENTLY HAZARDOUS SITUATION! If not avoided, **WILL RESULT** in death or serious injury.



WARNING: POTENTIALLY HAZARDOUS SITUATION! If not avoided, **COULD RESULT** in death or serious injury.



CAUTION: POTENTIALLY HAZARDOUS SITUATION! If not avoided, **MAY RESULT** in minor or moderate injury. It may also be used to alert against unsafe practices.

NOTATIONS

NOTE: General reference information for proper operation and maintenance practices.

IMPORTANT: Specific procedures or information required to prevent damage to unit or attachment.

PRACTICES AND LAWS

Practice usual and customary safe working precautions, for the benefit of yourself and others. Understand and follow all safety messages. Be alert to unsafe conditions and the possibility of minor, moderate, or serious injury or death. Learn applicable rules and laws in your area. Always follow the practices set forth in this manual.

REQUIRED OPERATOR TRAINING

Original purchaser of this unit was instructed by the seller on safe and proper operation. If unit is to be used by someone other than original purchaser; loaned, rented or sold, **ALWAYS** provide this manual and any needed safety training before operation.

SAFETY DECALS AND LOCATIONS

ALWAYS replace missing or damaged Safety Decals. Refer to Figure 2 below for Safety Decal locations.

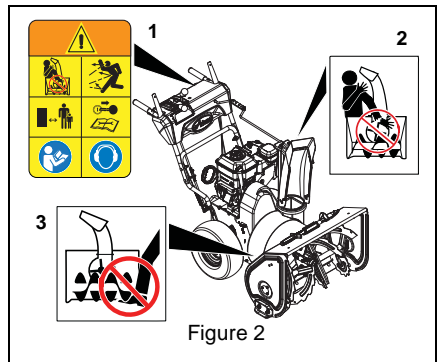

Figure 2

1. DANGER!



Danger!



ONLY use clean-out tool to clear blockages. NEVER use your hands.



Never direct discharge towards persons or property that may be injured or damaged by thrown objects.



Keep people away from unit while operating. Keep children out of work area and under watchful care of a responsible adult.



Stop engine, remove key, read manual before making any repairs or adjustments.



Read Owner/Operator Manual.



Wear appropriate hearing protection.

2. DANGER!



Danger!



ROTATING PARTS! ONLY use clean-out tool to clear blockages. NEVER use your hands. High speed impeller rotates below discharge opening. Wait for all moving parts to stop before removing clogs or servicing.

3. DANGER!



Danger!



ROTATING PARTS. Keep clear of auger while engine is running.

- Read Operator's Manual.
- Allow operation only by properly trained adult, never children.
- Stop engine and remove ignition key prior to leaving the operator's position for any reason.
- Keep all controls, guards and safety devices properly serviced and functional.
- Never direct discharge towards persons or property that may be injured or damaged by thrown objects.

EMISSION CONTROL SYSTEM

This equipment and/or its engine may include exhaust and evaporative emissions control system components required to meet U.S. Environmental Protection Agency (EPA) and/or California Air Resources Board (CARB) regulations. Tampering with emission controls and components by unauthorized personnel may result in severe fines or penalties. Emission controls and components can only be adjusted by an Ariens Company dealer or an authorized engine manufacturer's service center. Contact your Ariens Company Equipment Retailer concerning emission controls and component questions.

SAFETY RULES

Read, understand, and follow all safety practices in Owner/Operator Manual before beginning assembly or operating. Failure to follow instructions could result in personal injury and/or damage to unit.

ALWAYS remove key and/or wire from spark plug before assembly, maintenance or service. Unintentional engine start up can cause death or serious injury.

Complete a walk around inspection of unit and work area to understand:

- Work area
- Your unit
- All safety decals

ALWAYS check overhead and side clearances carefully before operation. ALWAYS be aware of traffic when operating along streets or curbs. Keep children and people away. Keep children out of work area and under watchful care of a responsible adult.

NEVER allow children to operate or play on or near unit. Be alert and shut off unit if children enter area.

DO NOT allow adults to operate unit without proper training. Only trained adults may operate unit. Training includes actual operation.

Keep area of operation clear of all toys, pets, and debris. Thrown objects can cause injury. Check for weak spots on docks, ramps or floors. Avoid uneven work areas and rough terrain. Stay alert for hidden hazards.

DO NOT operate near drop-offs, ditches, or embankments. Unit can suddenly turn over if a wheel is over the edge of a cliff or ditch, or if an edge caves in.

Falling snow, fog, etc. can reduce vision and cause an accident. Operate unit only when there is good visibility and light.

NEVER operate unit after or during the use of medication, drugs or alcohol. Safe operation requires your complete and unimpaired attention at all times.

NEVER allow anyone to operate this unit when their alertness or coordination is impaired.

DO NOT operate unit without wearing adequate winter outer garments. Wear adequate safety gear, including safety glasses with side shields, and protective gloves. Wear proper footwear to improve footing on slippery surfaces.

DO NOT wear loose clothing or jewelry and tie back hair that may get caught in rotating parts. Protect eyes, face and head from objects that may be thrown from unit. Wear appropriate hearing protection.

Avoid sharp edges. Sharp edges can cut. Moving parts can cut off fingers or a hand.

ALWAYS keep hands and feet away from all rotating parts during operation. Rotating parts can cut off body parts.

NEVER place your hands or any part of your body or clothing inside or near any moving part while unit is running.

ALWAYS keep hands away from all pinch points.

DO NOT touch unit parts which might be hot from operation. Allow parts to cool before attempting to maintain, adjust or service.

Never direct discharge towards persons or property that may be injured or damaged by thrown objects. Use extreme caution on gravel surfaces. Stay alert for hidden hazards or traffic. Adjust Skid Shoes so Scraper Blade does not contact gravel.

DO NOT throw snow any higher than necessary.

Deflected materials can cause injury and property damage.

Always stand clear of the discharge area when operating this unit.

Fumes from engine exhaust can cause injury or death. DO NOT run engine in an enclosed area. Always provide good ventilation.

ALWAYS disengage attachment, stop unit and engine, remove key and allow moving parts to stop before leaving operator's position.

ROTATING AUGER CAN CAUSE SERIOUS INJURY. NEVER ATTEMPT TO UNCLOG OR CLEAN UNIT WHILE ENGINE IS RUNNING.

Read, understand, and follow all instructions in the manual and on the machine before starting. Understand:

- How to operate all controls.
- The functions of all controls.
- How to STOP in an emergency.

Before starting engine, disengage control(s).

Use only approved extension cords and receptacles when starting units equipped with electric starter. DO NOT connect electric starter cord to any wiring system that is not a three-wire grounded system.

ALWAYS allow unit and engine to adjust to outdoor temperatures before clearing snow. DO NOT overload the machine capacity by attempting to operate or to clear snow at too fast a rate.

Slow down and turn corners slowly.

Do not operate in reverse unless absolutely necessary. ALWAYS back up slowly. Always look down and behind before and while backing.

Disengage attachment drive when traveling from one work area to another.

Abnormal Vibrations are a warning of trouble. Striking a foreign object can damage unit.

Immediately stop unit and engine. Remove key and wait for all moving parts to stop. Remove wire from spark plug. Inspect unit and make any necessary repairs before restart.

Before cleaning, removing clogs or making any inspections, repairs, etc.: disengage clutch(es), stop unit and engine, remove key, allow moving parts to stop. Allow hot parts to cool.

Run unit a few minutes after clearing snow to prevent freeze-up of attachment.

Disengage attachment when not in use.

Disengage all clutches before starting engine.

Adjust skid shoes to clear gravel or crushed rock surfaces safely.

Never leave a running unit unattended.

ALWAYS shut off engine before leaving unit.

ALWAYS remove key to prevent unauthorized use.

Never carry passengers.

Check clutch and brake operation frequently.

Adjust and service as required. All motion of drive wheels and auger/impeller must stop quickly when control levers are released.

DO NOT operate on steep slopes. DO NOT clear snow across the face of slopes. Keep all movement on slopes slow and gradual. DO NOT make sudden changes in speed or direction. Use a slow speed to avoid stops or shifts on slopes. Avoid starting or stopping on a slope.

DO NOT park unit on a slope unless absolutely necessary. When parking on a slope always block the wheels.

ALWAYS shut off engine, remove key, and close fuel shut-off valve or drain fuel when transporting unit on a truck or trailer.

Use extra care when loading or unloading unit onto trailer or truck.

Secure unit chassis to transport vehicle.

NEVER secure from rods or linkages that could be damaged.

DO NOT transport machine while engine is running.

Keep unit free of ice or other debris. Clean up oil or fuel spills.

This product is equipped with an internal combustion type engine. DO NOT use unit on or near any unimproved, forest-covered or brush covered land unless exhaust system is equipped with a spark arrester meeting applicable local, state or federal laws. A spark arrester, if it is used, must be maintained in effective working order by operator.

Fuel is highly flammable and its vapors are explosive. Handle with care. Use only an approved gasoline container with an appropriately sized dispensing spout.

NO smoking, NO sparks, NO flames. ALWAYS allow engine to cool before servicing.

NEVER fill fuel tank when engine is running or hot from operation.

NEVER fill or drain fuel tank indoors.

Replace fuel cap securely and clean up spilled fuel.

Never fill containers inside a vehicle or on a truck or trailer bed with a plastic liner. Always place containers on the ground away from your vehicle before filling.

When practical, remove gas-powered equipment from the truck or trailer and refuel it on the ground. If this is not possible, then refuel such equipment on a trailer with a portable container, rather than from a gasoline dispenser nozzle.

Keep the nozzle in contact with the rim of the fuel tank or container opening at all times until fueling is complete. Do not use a nozzle lock-open device.

If fuel is spilled on clothing, change clothing immediately.

Properly remove fuel before tipping unit up onto housing, so no spills will occur.

Secure unit so it will not tip over during maintenance.

ALWAYS keep protective structures, guards, and panels in good repair, in place and securely fastened. NEVER modify or remove safety devices.

DO NOT change engine governor settings or over-speed engine.

Fumes from engine exhaust can cause injury or death. DO NOT run engine in an enclosed area. Always provide good ventilation.

ALWAYS maintain unit in safe operating condition. Damaged or worn out muffler can cause fire or explosion.

Keep all hardware properly tightened. Check shear bolts frequently.

Maintain or replace safety and instruction labels, as necessary.

NEVER store unit with fuel in fuel tank, inside a building where any ignition sources are present such as hot water heaters, space heaters, or clothes dryers. Allow the engine to cool before storing in any enclosure.

Shut off fuel and allow engine to cool completely before storing in closed area or covering unit.

For extended storage, clean unit thoroughly. See Engine Manual for proper storage.

Use only attachments or accessories designed for your unit.

Check components frequently. If worn or damaged, replace with manufacturer's recommended parts.

ASSEMBLY



WARNING: AVOID INJURY. Read and understand the entire *Safety* section before proceeding.



WARNING: Dropping or tipping over boxed unit could result in personal injury or damage to unit.

PACKAGE CONTENTS

PACKAGE CONTENTS

Check the contents of your package for the parts listed below (Figure 3):

Item	Part No.	Qty	Description
The following parts are included as part of the Sno-thro Unit:			
1.	N/A	1	Sno-thro Unit
2.	07028500	2	3/8 in-16 x 3/4 in. Serrated Head Flange Bolt

The following parts are included as a part of the Lower Handlebar:

3.	00597451	1	Lower Handlebar
4.	06221600	4	5/16 in-18 x 2-1/4 in. Round Head Square Neck Bolt
5.	07500005	4	Handlebar Spacer
6.	06435700	4	Flat Steel Washer
7.	06407400	4	Locking Washer
8.	06530200	4	5/16 in-18 Locking Nylon Nut

9.	N/A	1	Upper Handlebar Assembly
10.	N/A	1	Discharge Chute Assembly
11.	N/A	1	921013, 022, 023, 031 – Chute Crank Assembly
12.	N/A	1	921017, 018 – Chute Rod
13.	N/A	1	Literature Pack
14.	06900302	1	Remote Wheel Lock Trigger Assembly
15.	06100007	1	1/4 in-20 Oval Head Machine Screw
16.	06305200	1	1/4 in. Internal Locking Washer

If any of the listed contents are missing contact your local Ariens dealer.

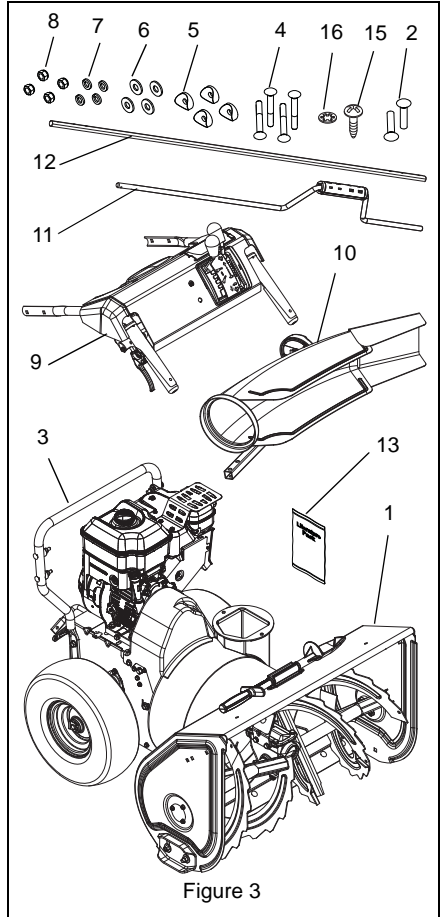

Figure 3

ASSEMBLY

Tools Required:

- Pliers
- Open-End Wrenches: 3/8, 7/16, 1/2, 9/16 in. and/or Adjustable Wrench
- Tire Gauge
- Torque Wrench (Optional)

Unfold Lower Handlebar

(Figure 4)

IMPORTANT: Be sure to block wheels or secure unit so it does not move during assembly.

1. Remove 3/8 in-16 x 3/4 in. serrated head flange bolt from the mounting holes on each side of the frame. Keep bolts.
2. Rotate lower handlebar out from unit so lower handlebar mounting holes align with mounting holes on the unit frame (Figure 4).

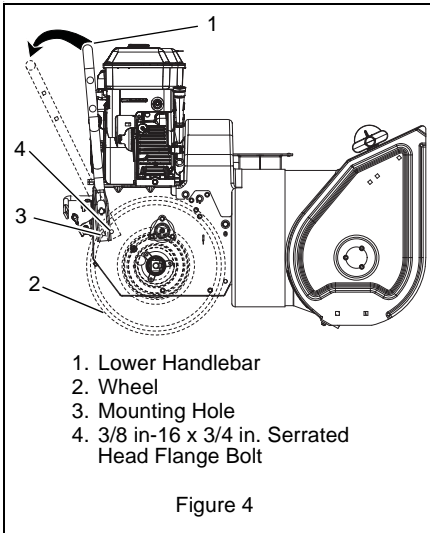

3. Secure lower handlebar to unit using the two 3/8 in-16 x 3/4 in. serrated head flange bolts removed in step 1.
4. Tighten all four bolts to 25 – 42 lbf-ft (33.9 – 56.9 N•m).

Attach Upper Handlebar Assembly

(Figure 5 and 6)

1. Remove handlebar hardware from lower handlebar. Keep hardware.
2. Attach upper handlebar assembly to lower handlebar using two sets of the handlebar hardware removed in step 1. One set to attach each side of the handlebars (Figure 5).

NOTE: DO NOT tighten hardware. Allow upper handlebar assembly to hang from the lower handlebars for the next step.

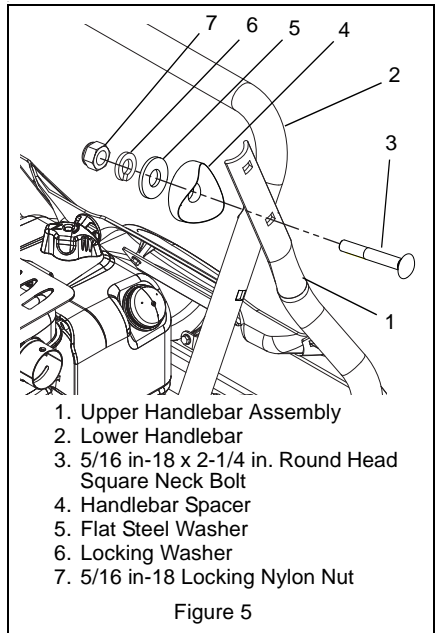

3. Hook spring end of attachment control cable to the clutch arm.
4. Hook spring end of the traction control cable to the cable eyelet on back of frame.

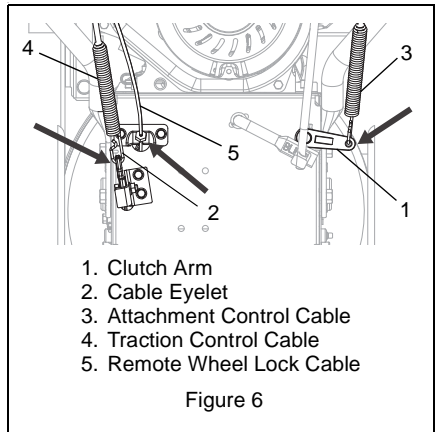

Unfold Upper Handlebar Assembly

(Figure 7 and 8)

1. Rotate the handlebar into operating position.

NOTE: Be careful not to damage cable spring hooks when rotating handlebar upward.

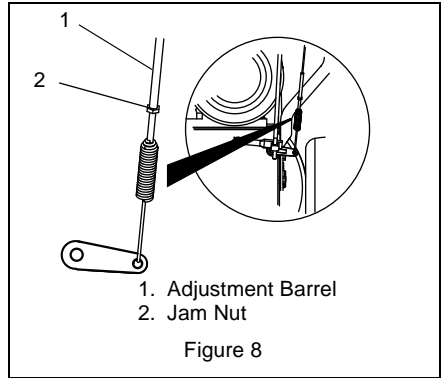
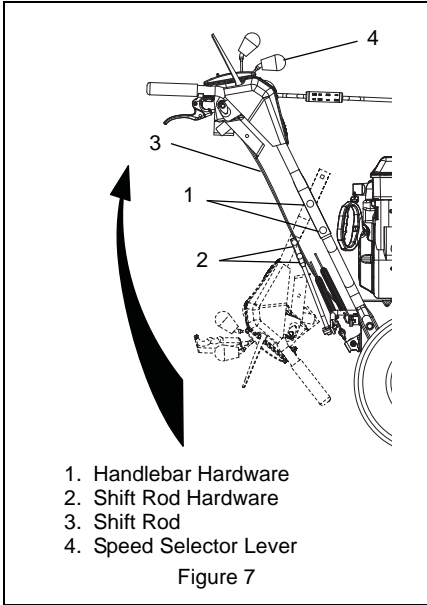

Connect Headlight Wire Harness

(Figure 9)

NOTE: The headlight wire harness comes attached to the upper handlebar assembly.

1. Route the wire harness along the interior of the right side of the handlebars.
2. Connect to the engine electrical plug.

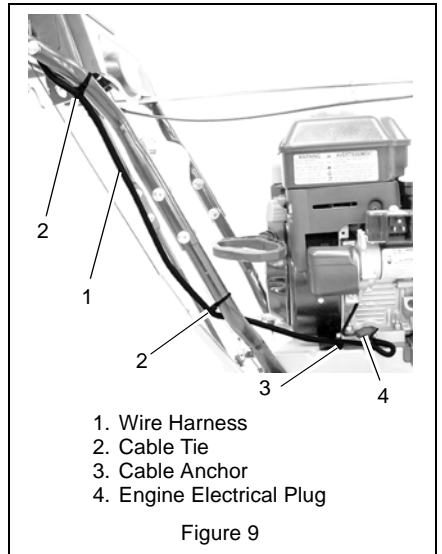

2. Install the remaining handlebar hardware attaching the upper handlebar assembly to the lower handlebar (Figure 5).
3. Tighten all hardware.
4. Remove packaging around shift rod.
5. Rotate shift rod into place and tighten hardware.
6. Connect shift rod to speed selector arm and adjust as specified in *Discharge Chute* on page 30.
7. Remove slack from attachment and traction cables using the following steps (Figure 37):
 - a. Loosen jam nut on cable adjustment barrel
 - b. Turn the adjustment barrel down to shorten cable and remove all cable slack.
 - c. Retighten jam nut.

3. Press cable anchor into mounting hole in the frame near the engine electrical plug.
4. Secure the wire harness to the handlebars using the cable ties attached to the wire harness.

Install Remote Wheel Lock Trigger Assembly

(Figure 10)

NOTE: Remote wheel lock trigger assembly comes attached to the Sno-thru unit.

1. Attach remote wheel lock trigger assembly to upper handlebar assembly using one 1/4 in-20 oval head machine screw and one 1/4 in. internal locking washer (Figure 10).

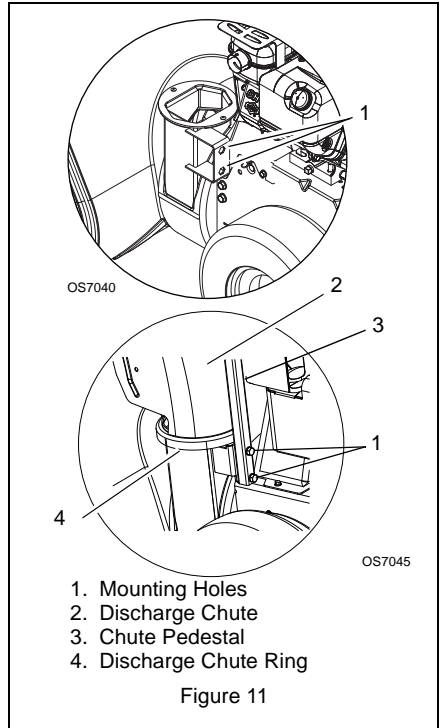
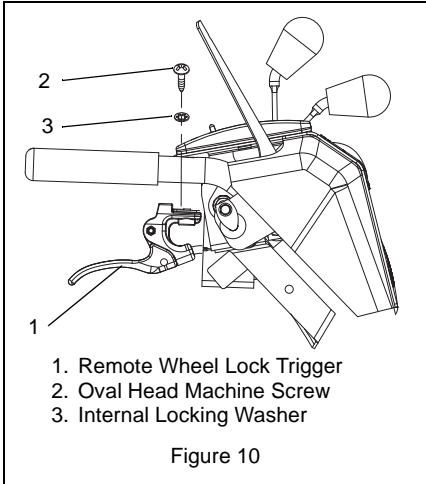

Install Discharge Chute and Discharge Chute Crank (921013, 022, 023, 031)

(Figure 11 and 12)

1. Grease underside of discharge chute ring (if not already greased).
2. Remove mounting hardware from auger housing (Figure 11).
3. Install discharge chute over opening in the auger housing. Finger tighten the mounting hardware removed in step 2.

NOTE: Leave discharge chute pedestal loose to help install the chute crank.

4. Insert the short end of the chute crank into the hole in the front of the control panel.

NOTE: Be careful not to damage nylon bushing when attaching crank to the control panel.

5. Connect the chute crank to the pinion gear on chute with hairpin.

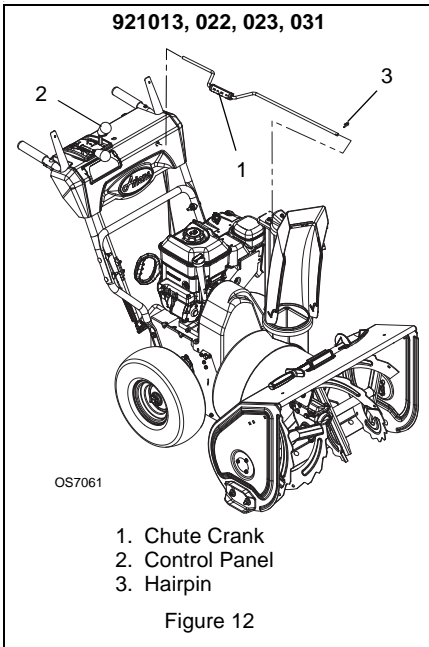

6. Orient the chute and pedestal to its most vertical position and tighten pedestal hardware to 15 – 31 lbf-ft (20 – 42 N•m) (Figure 11).

Install Discharge Chute, Chute Control, and Chute Rod (921017, 018)

(Figures 13, 14, 15, 16 and 17)

1. Grease underside of discharge chute ring (if not already greased) (Figure 11).
2. Remove mounting hardware from auger housing (Figure 11).
3. Install discharge chute over opening in the auger housing. Finger tighten the mounting hardware removed in step 2 (Figure 11).

NOTE: Leave discharge chute pedestal loose to help install the chute rod and connect it to the control assembly.

4. Remove rubber grommet from the control panel by pinching the long-edged sides together and pulling upward. Save rubber grommet (Figure 13).

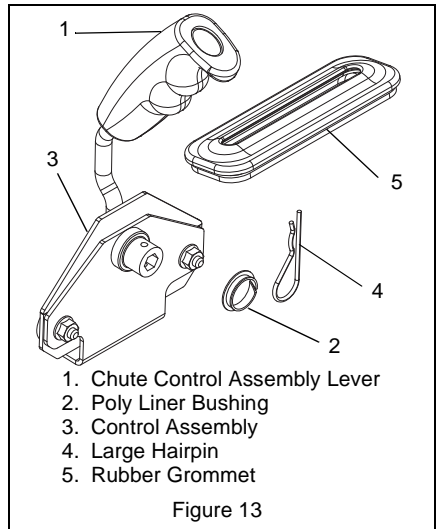

5. Remove and save the large hairpin from the control assembly (Figure 13).
6. Route chute control assembly below the crossbar of the lower handlebar (Figure 15). Slide the lever of the assembly through the underside of the hole in the control panel (Figure 14).
7. Insert the chute control assembly into the control assembly mounting hole under the control panel (Figure 14).

NOTE: Be sure the poly liner bushing is properly seated in the control assembly mounting hole.

NOTE: Mounted control lever should tip towards the engine.

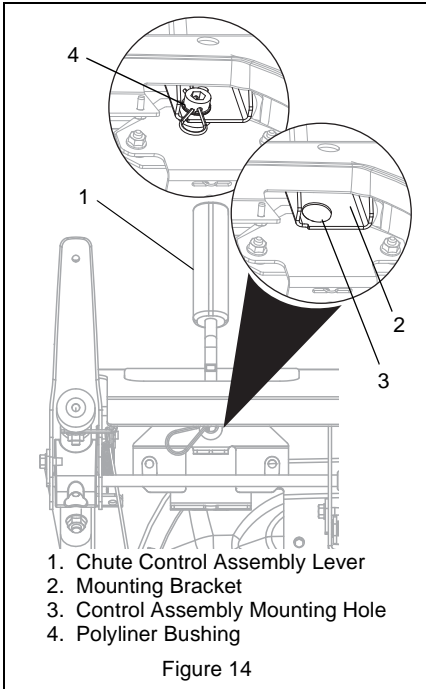

8. Install rubber grommet removed in step 4, by stretching rubber grommet over the top and around chute control lever.

NOTE: Make sure the groove around the entire edge of the rubber grommet is properly seated in the hole in the control panel.

9. Remove the gear cover from the gear assembly by removing 3/8 inch screw and lifting up cover (Figure 15).

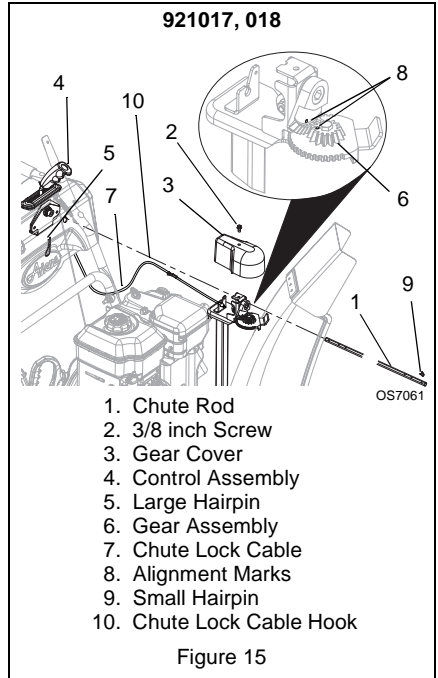

10. Release the gear assembly teeth by pushing and on the upper part of the gear lock. While the gear assembly teeth are released, rotate the discharge chute 90° counter-clockwise (Figure 11).

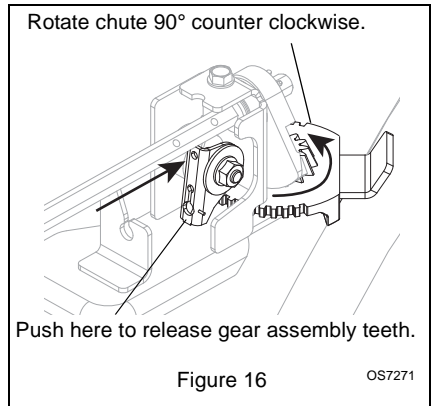

IMPORTANT: To ensure the discharge chute follows its full range of travel, make sure the control lever is pushed all the way to the left before installing and pinning the chute rod.

NOTE: Do not remove the small hairpin installed on the end of the chute rod (Figure 15).

11. Cut the cable tie that holds the gear assembly together. Make sure the gear components stay in place.
12. Align the holes on the end of the chute rod with the alignment marks on the gear assembly and slide the chute rod end, without a small hairpin, through the gear assembly, through the hook on the chute lock cable, and into the hex hole in the control assembly (Figure 15).

IMPORTANT: The hook on the chute lock cable will prevent the control cable from contacting the engine or muffler guard.

NOTE: After the chute rod has been inserted through the hex hole in the control assembly, placing the unit in the service position (see *Service Position* on page 24) will ease alignment and installation of the large hairpin.

13. Secure the chute rod to the control assembly with large hairpin removed in step 5. Use the hole location as shown in Figure 17. Insert the large hairpin with the loop end to the left of the chute rod so the chute control assembly lever follows a full range of travel.

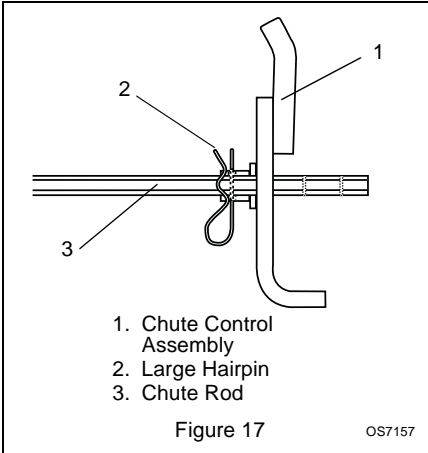

14. Replace the gear cover removed in step 9.
15. Orient the chute and pedestal to its most vertical position and tighten pedestal hardware to 15 – 31 lb-ft (20 – 42 N•m).
16. Make sure the discharge chute rotates left and right when you push the chute control assembly lever left and right.

NOTE: If chute does not stay in position, adjust as directed in *Discharge Chute* on page 19, or repair before operation.

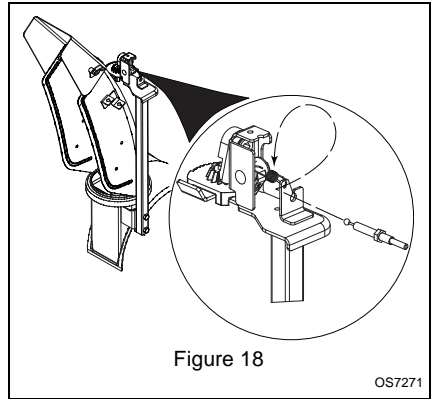

Remote Deflector Control

(Figure 19)

Connect the cable end to the cable anchor on the discharge deflector before clipping the cable to the cable bracket on the discharge chute.

1. Route deflector remote cable along the left side of the chute pedestal.
2. Insert the barrel on the cable end into the bracket on left side of chute deflector (Figure 19).
3. Hold seal out of the way while routing the cable through the bracket on the left side of the discharge chute, and then push the cable fitting into the bracket.
4. Push the seal securely over the end of the cable fitting to prevent water from entering the cable.

Check deflector travel. Adjust nut on cable end under handlebar to obtain full travel, if necessary (see *Remote Deflector Control* on page 29).

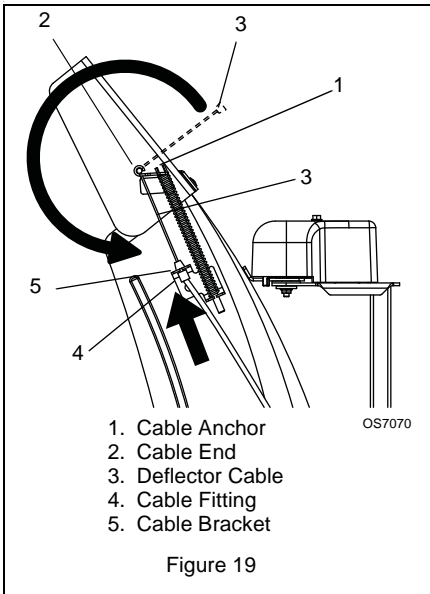

Check Function of Dual Handle Interlock

Without the engine running, press down (engage) both clutch levers. Release attachment clutch lever. Attachment clutch should remain engaged until traction clutch lever is released, then both clutches *must* disengage. If they do not, contact your Dealer for repairs.

Check Tire Pressure (921013, 017, 018, 022, 031)

Check tire pressure and adjust to the pressure listed on tire sidewall.



CAUTION: Avoid injury! Explosive separation of tire and rim parts is possible when they are serviced incorrectly:

- Do not attempt to mount a tire without the proper equipment and experience to perform the job.
- Do not inflate the tires above the recommended pressure.
- Do not weld or heat a wheel and tire assembly. Heat can cause an increase in air pressure resulting in an explosion. Welding can structurally weaken or deform the wheel.
- Do not stand in front or over the tire assembly when inflating. Use a clip-on chuck and extension hose long enough to allow you to stand to one side.

Check Track Tension (921023)

Check tracking of unit with the differential locked, and tension of tracks (see *Track Tension Adjustment* on page 35).

Check Auger Gearcase Oil

Check oil level in auger gearcase (see *Check Auger Gearcase* on page 26).

Check Engine Crankcase Oil

IMPORTANT: The engine is shipped with oil in crankcase. Refer to Engine Manual for detailed instructions.

Fill Engine Fuel Tank

Fill fuel tank. **DO NOT OVERFILL!** See *FILLING FUEL TANK* on page 21

For Model 921013, 018: Remove the plug from the fuel tank and install the fuel cap located in the attached bag.

Check Function of all Controls

Ensure unit runs and performs properly. Refer to *OPERATION* on page 18.

Run-in Attachment Belt

1. Start unit in a well-ventilated area according to *Starting and Shut Off* on page 23.
2. Engage attachment clutch lever and run attachment for about 15 minutes.
3. Stop unit, wait for all moving parts to stop, and remove spark plug wire.
4. Adjust belt finger, if necessary. See *Check Belt Finger Clearance* on page 32.
5. Adjust clutch idler according to *Attachment Clutch/Brake Adjustment* on page 30.

CONTROLS AND FEATURES

921017, 018

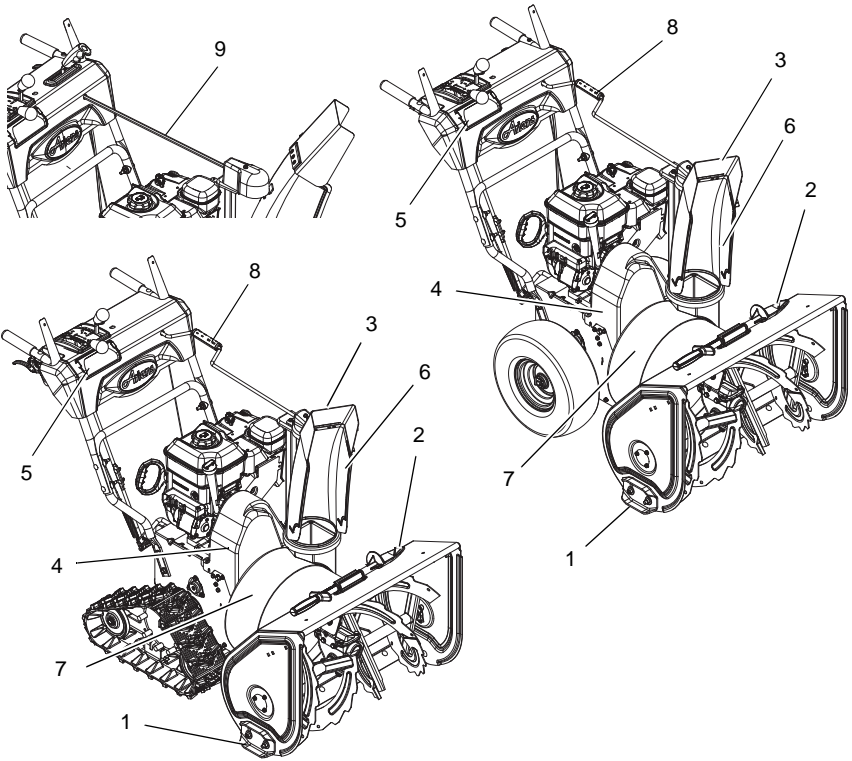
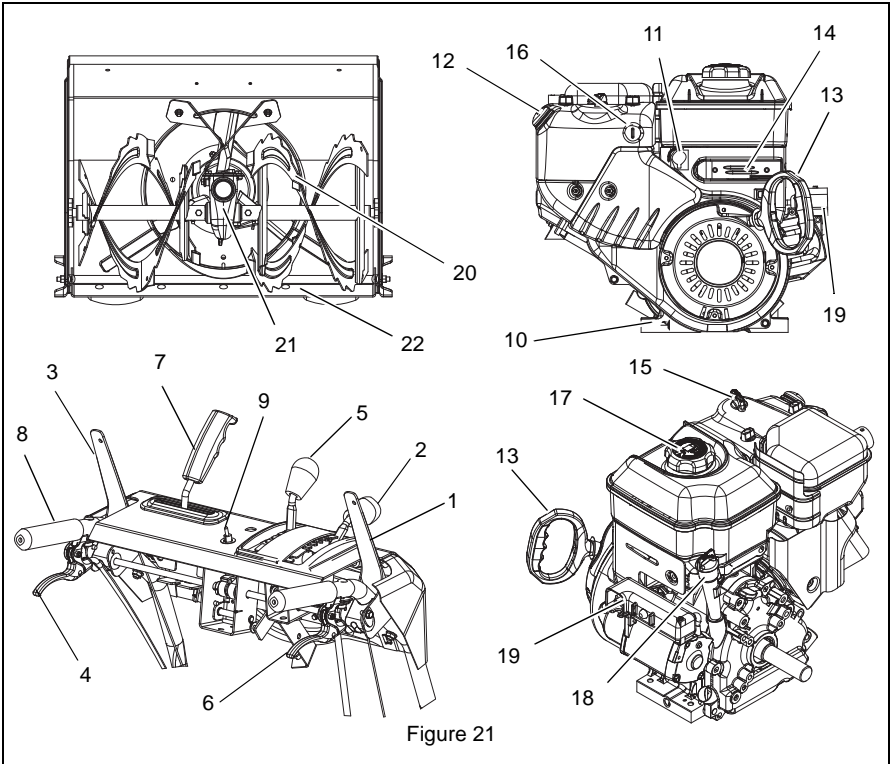

Figure 20

1. Skid Shoe
2. Clean-Out Tool
3. Remote Discharge Chute Deflector
4. Belt Cover
5. Headlight
6. Discharge Chute
7. Impeller
8. Chute Crank (921013, 022, 023, 031)
9. Quick Turn Chute Control Rod (921017, 018)



- | | |
|---|---------------------------|
| 1. Attachment Clutch Lever | 12. Primer Bulb |
| 2. Speed Selector | 13. Recoil Starter Handle |
| 3. Traction Drive Clutch Lever | 14. Throttle |
| 4. Remote Wheel Lock (921013, 022) | 15. Choke Control Knob |
| 5. Remote Deflector Control | 16. Ignition Key |
| 6. Height Adjuster Trigger (921023) | 17. Fuel Tank and Cap |
| 7. Quick Turn Chute Control (921017, 018) | 18. Oil Fill/Dipstick |
| 8. Handwarmers (921013, 017, 018) | 19. Electric Start |
| 9. Handwarmers Switch (921013, 017, 018) | 20. Auger |
| 10. Oil Drain | 21. Auger Gearcase |
| 11. Fuel Shut-Off Valve | 22. Scraper Blade |

OPERATION



WARNING: AVOID INJURY. Read and understand the entire *Safety* section before proceeding.



WARNING: To avoid injury to hands and feet, always disengage clutches, shut off engine, and wait for all movement to stop before unclogging or working on snow thrower.

Keep hands and feet away from auger and impeller.

CONTROLS AND FEATURES

See *CONTROLS and FEATURES* on page 16 for all Controls and Features locations.

Dual Handle Interlock

When Attachment Clutch and then Traction Drive Clutch are engaged, the Attachment Clutch will remain engaged (lever down) if released. To stop attachment, release Traction Drive Clutch and both clutches will disengage.

Traction Drive Clutch – Left Hand Lever

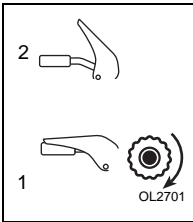

Squeeze the Traction Drive Clutch Lever against the Handlebar (1) to engage wheel drive for propelling unit. Forward speed will vary according to snow depth and moisture content.

Release lever (2) to stop movement.

NOTE: When traveling to or from the area to be cleared, press down on the handlebars enough to raise the front of the unit slightly off the surface. Engage the traction drive clutch without engaging the attachment drive clutch.

Attachment Clutch – Right Hand Lever

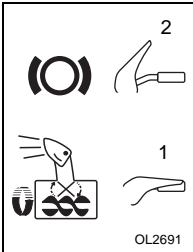

Squeeze Attachment Clutch Lever against handlebar (1) to engage attachment. Release both clutch levers (2) to disengage power and apply brake to attachment.

IMPORTANT: If the belt squeals when the attachment clutch lever is engaged, the impeller may be frozen in the auger housing. Immediately release the attachment clutch lever and move the unit into a heated area to thaw.

NOTE: If belt squeals when impeller turns freely, see *Attachment Clutch/Brake Adjustment* on page 30.

Ignition Switch



Operate the ignition switch with the removable key. To start the engine, turn the key to Start. To stop the engine, turn the key to Off.

Primer Bulb

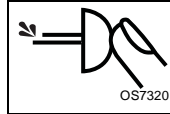

Pushing the primer bulb in adds fuel for easier engine start. Refer to *Starting and Shut Off* on page 23.

Speed Selector

Position the Speed Selector in the appropriate speed notch to control forward and reverse travel.

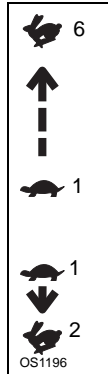

Forward:

- (6) Fastest
- (1) Slowest

Reverse:

- (1) Slow
- (2) Fast

IMPORTANT: DO NOT change motion from forward to reverse with clutch engaged. Forward speed can be changed without declutching.

Choke Control Knob

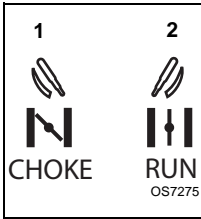

1. Choke Closed position: chokes off air to engine for easier start.

2. Choke Open position: allows for normal operation.

IMPORTANT: Gradually open choke after engine starts.

Throttle

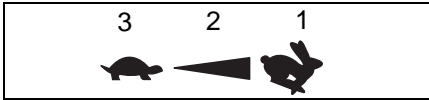

The throttle controls the engine speed. To increase or decrease the engine speed, adjust to:

1. Fast (normal or warm starts)
2. Part-Throttle
3. Slow (cold weather starts)
4. Stop (engine is off)

Electric Starter

The electric starter will start a properly choked and cranked engine when the starter button is pushed. Refer to *Starting and Shut Off* on page 23.

Recoil Starter Handle

When pulled, handle will turn engine over.

IMPORTANT: DO NOT let handle snap back against starter.

Snow Clean-Out Tool

(Figure 22)

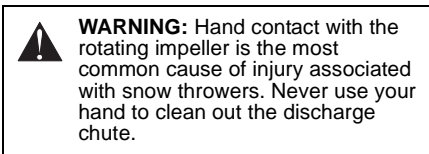

WARNING: Hand contact with the rotating impeller is the most common cause of injury associated with snow throwers. Never use your hand to clean out the discharge chute.

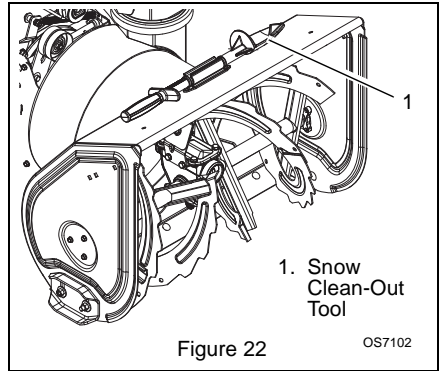

Figure 22

OS7102

To clear the discharge chute:

1. Shut off the engine.
2. Wait 10 seconds and make sure impeller blades have stopped rotating.
3. Remove the snow clean-out tool (1) from the auger housing and use it to remove the clog from the discharge chute.
4. Replace the snow clean-out tool on the auger housing.

Remote Deflector Control

Place deflector into position before operation. DO NOT throw snow any higher than necessary.

Place deflector remote in a forward notch to throw snow lower. Place deflector remote in a rearward notch to throw snow higher.

Discharge Chute

Discharge chute rotates 200°.

ALWAYS position discharge chute in safe direction and angle, away from operator and bystanders, before starting engine.

Quick Turn Chute Control (921017, 018)

(Figure 23)

IMPORTANT: If chute does not stay in set position, adjust as directed in *Discharge Chute* on page 30, or repair before operation.

Rotate the Chute with Discharge Chute Control (Figure 23).

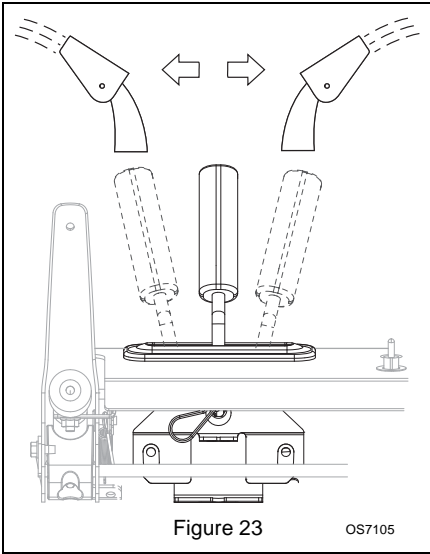

IMPORTANT: DO NOT force frozen chute controls. If frozen, take to warm place until controls are free.

Discharge Chute Crank (921013, 022, 023, 031)

(Figure 24)

IMPORTANT: If chute does not stay in set position, adjust as directed in *SERVICE AND ADJUSTMENTS* on page 27, or repair before operation.

Rotate the Chute with Discharge Chute Crank.

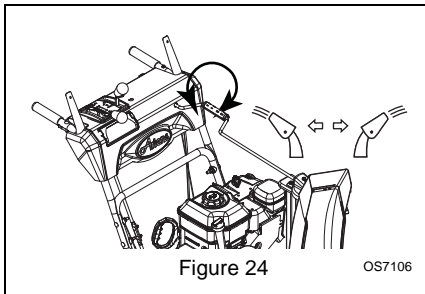

IMPORTANT: DO NOT force frozen chute controls. If frozen, take to warm place until controls are free.

Axle Lock Pin (921031)

(Figure 25)

Use the axle lock pin to lock or unlock the right or left wheel. Lock both wheels to increase traction; unlock one wheel to allow for easier turning of the unit.

NOTE: Unit will not drive with both wheels unlocked.

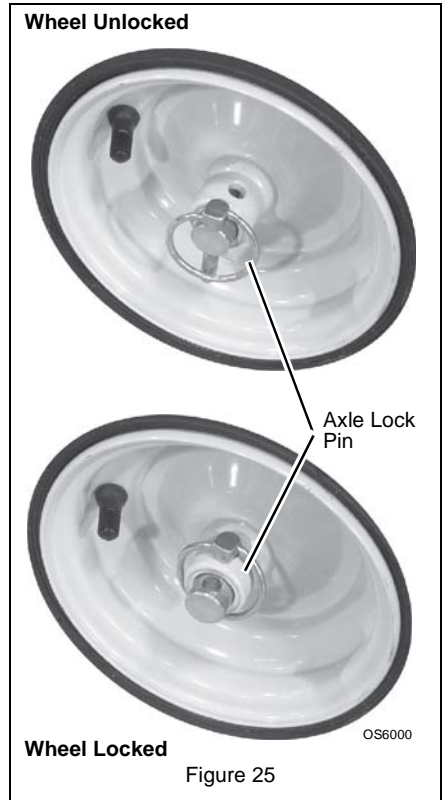

Remote Wheel Lock (921013, 022)

Squeeze and release the remote wheel lock control to lock the left wheel for better traction when throwing snow or to unlock the left wheel for easier steering.

NOTE: The wheel lock will not release when under load. Do not unlock the wheel while turning. If the wheel lock will not release, turn the unit slightly left or right to relieve axle load and release the axle lock.

If remote wheel lock does not lock or unlock properly, adjust or repair before operation (see *Remote Wheel Lock* on page 28).

Heated Handles (921013, 017, 018)

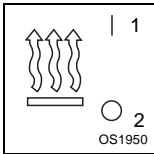

Turn the heated handles switch to the ON (1) position to activate. Turn the switch to the OFF (2) position to deactivate.

Scraper Blade

The scraper blade allows better contact with the surface being cleared. It also prevents damage to the housing from normal usage.

IMPORTANT: DO NOT allow Scraper Blade to wear too far or Auger/Impeller housing will become damaged.

Skid Shoes

The skid shoes control the distance between the scraper blade and the ground. Adjust skid shoes equally to keep blade level with the ground. Refer to *Pre-Start* on page 22 for recommended settings.

Track Angle (921023)

(Figure 26)

The track angle can be adjusted to position the auger housing for level clearing, deep cutting or transport.

Squeeze the handlebar trigger and press down on the handlebars to move the auger housing into an up position. Release the trigger to hold the position.

Lift up on the handlebars and squeeze and release the handlebar trigger to move the auger housing into a down position.

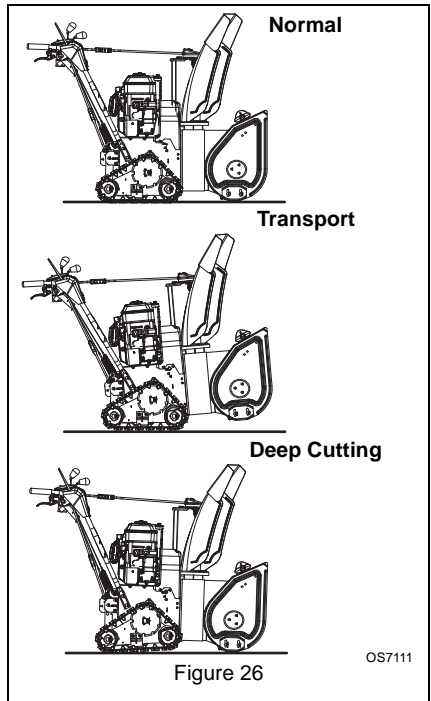

FILLING FUEL TANK



WARNING: AVOID INJURY. Read and understand the entire *Safety* section before proceeding.

GASOLINE

IMPORTANT: ALWAYS use gasoline that meets the following guidelines:

- Clean, fresh gasoline.
- A minimum of 87 octane/87 AKI (91 RON). High altitude use may require a different octane. Consult your engine manual.
- Gasoline with up to 10% ethanol (gasohol) or up to 10% MTBE (methyl tertiary butyl ether) is acceptable.
- Use of any gasoline other than those approved above will void the engine warranty. If the pumps are not marked for the content of alcohol or ethers, check ethanol and MTBE levels with the fuel supplier.
- Do not modify the fuel system to use different fuels.
- Never mix oil and gasoline.

NOTE: All gasoline is not the same. If the engine experiences starting or performance problems after using a new gasoline, switch to a different fuel provider or fuel brand.

IMPORTANT: Excessively oxygenated or reformulated fuels (fuels blended with alcohols or ethers) can damage the fuel system or cause performance problems. If any undesirable operating problems occur, use a gasoline with a lower percentage of alcohol or ether.

Add Fuel Stabilizer to Extend Fuel Storage Life

IMPORTANT: Fuel stabilizer is recommended for extended storage (see *Fuel System* on page 36).

Add Fuel to Fuel Tank

1. ALWAYS place unit in open or well-ventilated area.
2. Stop engine and allow to cool.
3. Clean Fuel Cap and surrounding area to prevent dirt from entering Fuel Tank.
4. Remove fuel caps.

IMPORTANT: Refer to Engine Manual for correct type and grade of fuel.

5. Fill fuel tank to the bottom of filler neck. See *SPECIFICATIONS* on page 38 for fuel tank capacity.

IMPORTANT: DO NOT OVERFILL! This equipment and/or its engine may include evaporative emissions control system components, required to meet EPA and/or CARB regulations, that will only function properly when the fuel tank has been filled to the recommended level. Overfilling may cause permanent damage to evaporative emissions control system components. Filling to the recommended level ensures a vapor gap required to allow for fuel expansion. Pay close attention while filling the fuel tank to ensure that the recommended fuel level inside the tank is not exceeded. Use a portable gasoline container with an appropriately sized dispensing spout when filling the tank. Do not use a funnel or other device that obstructs the view of the tank filling process.

6. Replace fuel cap and tighten.
7. ALWAYS clean up spilled fuel.

Fuel Shut-Off Valve

IMPORTANT: The fuel shut-off valve MUST be in the closed position prior to transporting the unit.

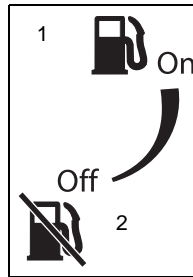

The fuel shut-off valve has two positions:

Open Position (1): Use this position to run the unit.

Closed Position (2): Use this position to service, transport, or store the unit.

PRE-START

4. Frozen Impeller

IMPORTANT: Before starting engine, check impeller to be sure it is not frozen.

To check impeller:

1. With ignition key switch in "Stop" position, squeeze Attachment Clutch Lever to Engaged position.
2. Pull Recoil Starter Handle.
3. If Impeller is frozen, (cannot pull Starter Handle) move unit to a heated area and thaw to prevent possible damage.

5. Check Function of Clutches

If clutches do not engage or disengage properly, adjust or repair before operation. See *Attachment Clutch/Brake Adjustment* on page 30.

6. Check Dual Handle Interlock

Without the engine running, press down (engage) both clutch levers. Release attachment clutch lever. Attachment clutch should remain engaged until traction clutch lever is released, then both clutches *must* disengage.

If clutches do not engage or disengage properly, adjust or repair before operation (see *Attachment Clutch/Brake Adjustment* on page 30).

7. Check Remote Wheel Lock (921013, 022)

Squeeze and release the remote wheel lock control to lock the left wheel for better traction when throwing snow or to unlock the left wheel for easier steering.

If remote wheel lock does not lock or unlock properly, adjust or repair before operation (see *Remote Wheel Lock* on page 28).

8. Check Axle Lock Pins (921031)

Use the axle lock pins to lock or unlock the wheels. Lock both wheels to increase traction; unlock one wheel to allow for easier turning of the unit.

9. Check Skid Shoes

Check and adjust Skid Shoes (See *Skid Shoes* on page 27). Allow 1/8 in. (3 mm) between scraper blade and hard, smooth surface(s). Allow 7/8 in. (22 mm) between scraper blade and uneven or gravel surfaces.

10. Check Engine Fuel & Crankcase Oil



WARNING: AVOID INJURY. Read and understand the entire *Safety* section before proceeding.

Check and add fuel if required. Check that the engine crankcase oil is full using dipstick. Refer to Engine Manual for detailed instructions.

TO STOP IN AN EMERGENCY

Immediately release both control levers to stop unit in an emergency. Stop engine, remove key and wait for all rotating parts to stop before leaving operator's position.

STARTING AND SHUT OFF



WARNING: FAILURE TO FOLLOW INSTRUCTIONS could result in personal injury and/or damage to unit. DO NOT attempt to start your unit at this time. Read entire Owner/Operator Manual and the Engine Manual first.

IMPORTANT: Allow unit and engine to adjust to the outdoor temperature before clearing snow. Before shut-off, run the attachment a few minutes to prevent impeller freeze-up.

NOTE: Try out each control without the engine running to see how it works and what it does.

Manual Start

1. Turn discharge chute straight ahead.
2. Make sure that the traction clutch and attachment drive clutch levers are fully disengaged.
3. Push Primer Bulb 2 or 3 times for cold engine.

NOTE: When temperature is below -15° F (-26° C) additional priming may be needed.

4. If engine is cold, apply choke. See Engine Manual for detailed instructions.

NOTE: A warm engine requires less choking than a cold engine.

5. Set throttle to proper starting position. Put the ignition key in the ignition switch and turn it to the "Start" position.
6. Grasp starter handle and pull rope out slowly until it pulls harder. Let rope rewind slowly.
7. Pull rope with a rapid continuous full arm stroke. Let rope rewind slowly.

IMPORTANT: DO NOT let Starter Handle snap against Starter.

8. Repeat steps 6 and 7 until engine starts. (If engine does not start, refer to *TROUBLESHOOTING* on page 37.)
9. Adjust choke as needed.
10. Set throttle to Part Throttle or Slow position for adaptation to outside temperature or travel. Set throttle to Fast position for normal operation.

Electric Start (120V)

1. Connect extension cord to starter.

IMPORTANT: Prevent damage to unit. Know voltage of your starter and only use matching outlets.

2. Plug extension cord into 120V 3-wire, grounded outlet.

IMPORTANT: Use only Ariens extension cord (P/N 02483100) or an equivalent cord that is rated for a minimum of 13 amps, grounded, UL listed, CSA certified and labeled as suitable for outdoor use.

3. Turn discharge chute straight ahead.
4. Make sure that the traction clutch and attachment drive clutch levers are fully disengaged.
5. Push Primer Bulb 2 or 3 times for cold engine.

NOTE: When temperature is below -15° F (-26° C) additional priming may be needed.

6. Set throttle to proper starting position. Put the ignition key in the ignition switch and turn it to the "Start" position.
7. If engine is cold, apply choke. A warm engine requires less choking than a cold engine. See Engine Manual for detailed instructions.
8. Set throttle to proper starting position.
9. Press starter button on engine until engine starts.

IMPORTANT: DO NOT operate starter more than 15 seconds per minute, as overheating and damage can occur. (If engine does not start, refer to *TROUBLESHOOTING* on page 37.)

10. Adjust choke as needed.
11. Disconnect power cord from outlet, then starter.

12. Set throttle to Part Throttle or Slow position for adaptation to outside temperature or travel. Set throttle to Fast position for normal operation.

Shut Off

1. Release Traction Drive Clutch Lever and allow unit to come to a complete stop.
2. Run Impeller a few minutes after use to prevent freeze-up of Impeller.
3. Release Attachment Clutch Lever and wait for all moving parts to come to a complete stop.
4. Move Throttle to the "Slow" position.
5. Remove key.

SNOW REMOVAL

IMPORTANT: Allow unit and engine to adjust to the outdoor temperature before clearing snow.

NOTE: Attachment clutch should be engaged before wheel drive clutch when throwing snow.

1. Select Speed Control position and direction.
2. Engage Attachment Clutch – Right Hand Lever.
3. Engage Traction Drive Clutch – Left Hand Lever.

IMPORTANT: DO NOT overload unit capacity by attempting to clear snow at too fast a rate. Use slow speed to clear deep or hard packed snow.

Tips for Operation

Snow is best removed as soon as possible after snow fall.

To clear an area, run unit in an overlapping series of paths. For large areas, start in the middle and throw snow to each side, so snow is not cleared more than once.

ALWAYS direct snow away from area to be cleared and with direction of the wind.

TRAVELING

To travel from one work area to another:

1. Set Throttle to Slow or Part-Throttle position.
2. **921013, 017, 018, 022, 031:** Press down on handlebars enough to raise front of unit slightly off surface.
- 921023:** Place the unit in the transport position (see *Track Angle* on page 21).
3. Engage wheel or track drive clutch without engaging attachment drive clutch.

TRANSPORT

ALWAYS shut off engine, remove key, and close fuel shut-off valve when transporting unit on a truck or trailer.

Use extra care when loading or unloading unit onto trailer or truck.

Secure unit chassis to transport vehicle. NEVER secure from rods or linkages that could be damaged.

DO NOT transport machine while engine is running.

MAINTENANCE

Ariens Dealers will provide any service or adjustments which may be required to keep your unit operating at peak efficiency. Should engine service be required, contact an Ariens dealer or an authorized engine manufacturer's service center.



WARNING: AVOID INJURY. Read and understand the entire *Safety* section before proceeding.

SERVICE POSITION



WARNING: Before tipping unit up onto housing, remove fuel so no spills will occur. Ensure unit is secure and will not tip over during maintenance.

1. Shut off engine, remove key, disconnect spark plug wire and allow unit to cool completely.
2. Close fuel shut-off valve (see *Fuel Shut-Off Valve* on page 22).
3. Drain fuel tank and fuel system (see Engine Manual for complete instructions).
4. Place unit on a flat level surface. Tip unit forward onto front of auger housing for service.

IMPORTANT: Ensure unit is secure and will not tip over. Strap and clamp onto bench if needed.

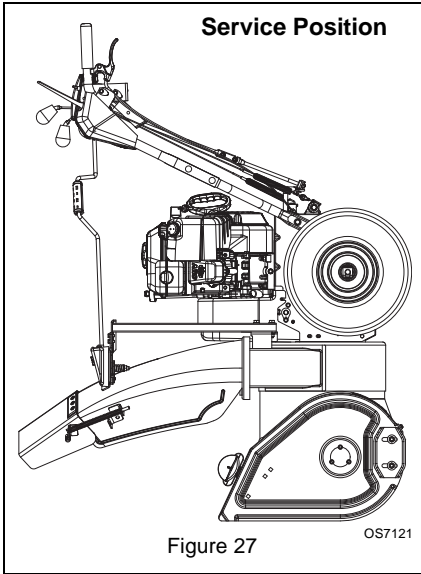

Figure 27

MAINTENANCE SCHEDULE

The chart below shows the recommended maintenance schedule that should be performed on a regular basis. More frequent service may be required.

MAINTENANCE SCHEDULE				
Service Performed	Each Use	Every 5 hrs.	Every 25 hrs.	Yearly
Check Dual Handle Interlock	•			
Check Fasteners	•			
Check Clutch Operation	•			
Clean Engine	•			
Check Engine Oil	•	•		
Change Engine Oil**				
Check Tire Pressure			•	
Check Auger Gearcase			•	•
General Lubrication			•	•
** Refer to Engine Manual for detailed instructions				

CHECK DUAL HANDLE INTERLOCK

Without the engine running, press down (engage) both clutch levers. Release attachment clutch lever. Attachment clutch should remain engaged until traction clutch lever is released, then both clutches *must* disengage.

CHECK FASTENERS

Make sure all hardware is tightened properly.

CHECK CLUTCH OPERATION

Auger / impeller must stop within 5 seconds when attachment clutch/impeller brake lever is released.

Wheels must stop quickly when traction drive clutch lever is released.

If clutches do not engage or disengage properly, adjust or repair before operation. See *Attachment Clutch/Brake Adjustment* on page 30 and *Attachment Drive Belt Replacement* on page 32.

CLEAN ENGINE

Refer to Engine Manual for detailed instructions.

CHECK ENGINE OIL

The engine crankcase oil should be checked every 5 hours of operation. Oil level **MUST** be maintained in safe operating range on dipstick at all times or engine damage will result (See Engine Manual).

Park unit on a level surface. Refer to Engine Manual for detailed instructions.

CHANGE ENGINE OIL

Refer to Engine Manual for detailed instructions.

CHECK TIRE PRESSURE (921013, 017, 018, 022, 031)

Keep tires at pressure listed on the tire sidewall. See *Check Tire Pressure* on page 15.

CHECK AUGER GEARCASE

IMPORTANT: Proper oil level must be maintained.

Gear cases are filled to the correct level at the factory. Unless there is evidence of leakage, no additional lubricant should be required. Check oil level each season or every 25 hours of operation.

IMPORTANT: Be sure unit is resting on a level surface before checking lubricant levels.

To ensure adequate lubricant level:

1. Remove filler plug and seal washer (Figure 28). Lubricant must be 2.38 in. – 2.63 in. (6.05 cm – 6.68 cm) from the flat surface of the inspection cover.

IMPORTANT: DO NOT remove the inspection cover.

2. Check oil level with suitable dipstick device. Add lubricant if required.

NOTE: Inspect seal washer for wear or rubber deterioration and replace as needed.

IMPORTANT: Use only Ariens L3 synthetic severe duty gear lube (Part Number 00068800). Use of other lubricants will void unit warranty.

3. Reinstall filler screw and seal washer to 80 lbf-in. (9 N•m).

IMPORTANT: DO NOT OVER-TORQUE! Note that measurements are in pound force inches (lbf-in) and NOT pound force foot (lbf-ft).

IMPORTANT: Be sure to install seal washer with rubber side down (Figure 28).

IMPORTANT: Improper torquing, omission of seal washer, or incorrect installation of seal washer will void unit warranty.

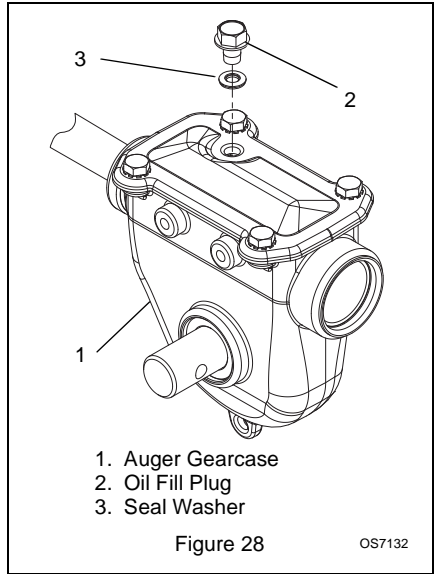

GENERAL LUBRICATION

IMPORTANT: Wipe each fitting clean before and after lubrication.

IMPORTANT: DO NOT allow grease or oil to get on friction disc, friction plate or belts.

NOTE: Apply Ariens Hi-Temp Grease or equivalent to the lubrication fittings. See *SERVICE PARTS* on page 36.

Sno-Thro should be lubricated (Figure 29) at beginning of season or every 25 operating hours.

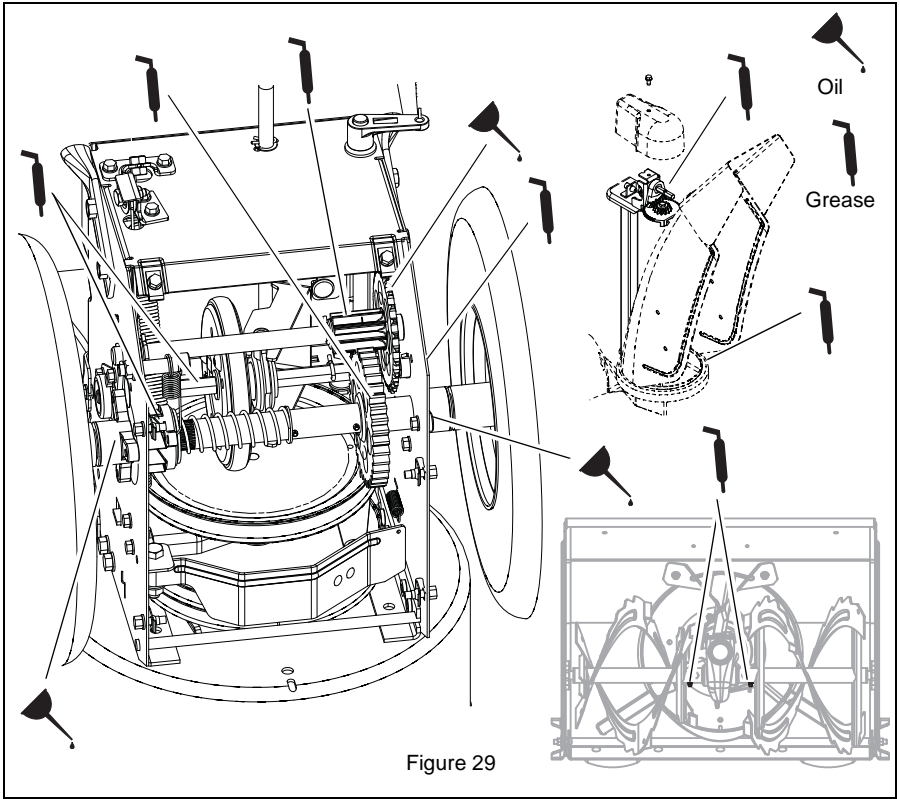

Figure 29

SERVICE AND ADJUSTMENTS



WARNING: AVOID INJURY. Read and understand the entire *Safety* section before proceeding.

SCRAPER BLADE

IMPORTANT: Damage to housing will result if blade wears down too far.

Scraper blade is adjustable to compensate for wear.

To adjust scraper blade:

1. Tip unit back onto handlebar, support housing and loosen nuts retaining blade.
2. Reposition scraper blade and tighten lock nuts.
3. Adjust skid shoes.

IMPORTANT: ALWAYS adjust skid shoes after adjusting scraper blade to prevent premature wear to scraper blade or damage to housing.

SKID SHOES

(Figure 30)

Skid Shoes should be adjusted as conditions require.

1. Position unit on a hard, flat, smooth level surface.
2. Adjust skid shoes by inserting a spacer of desired thickness under center of scraper blade, loosen skid shoe hardware, slide skid shoes to flat surface. Allow 1/8 in. (3 mm) between scraper blade and hard smooth surfaces. Allow 7/8 in. (22 mm) between scraper blade and uneven or gravel surfaces. Retighten hardware.

NOTE: Keep housing level by adjusting skid shoes equally.

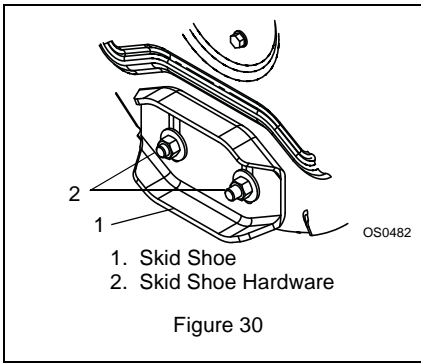

SHEAR BOLTS

(Figure 31)

IMPORTANT: Use only Ariens OEM shear bolts for replacement. Use of any other type of shear bolt may result in severe damage to unit. See *SERVICE PARTS* on page 36.

Occasionally a foreign object may enter the auger/impeller housing and jam the auger, breaking shear bolts which secure the auger to the shaft. This allows auger to turn freely on the shaft which may help prevent damage to gear drive.

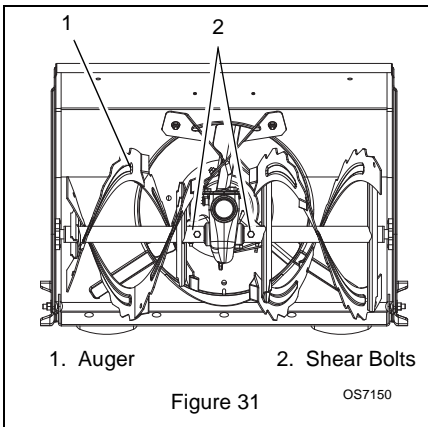

For Replacement:

1. Align shear bolt holes in auger with shear bolt holes in the shaft.
2. Drive shear bolt through hole (if shear bolt was broken this will drive remaining part from shaft).
3. Secure shear bolt with nut.

NOTE: DO NOT overtighten the shear bolt. Tighten shear bolt to 5.8 – 12.2 lbf-ft (7.9 – 16.5 N•m).

REMOTE WHEEL LOCK

(921013, 022)

(Figure 32)

If remote wheel lock does not lock or unlock:

1. Place unit in service position (see *Service Position* on page 24).
2. Loosen jam nuts on cable. Make sure the bottom jam nut is loosened enough to remove slack from cable (Figure 32).
3. Pull the cable adjuster to remove slack between the cable adjuster and the extension spring and hold the cable adjuster in position while finger tightening the top jam nut against the bracket. Do not extend the spring or engage the mechanism.
4. Tighten the bottom jam nut.
5. Check function of remote wheel lock. If wheel lock does not function properly, remove bottom cover to check cable slack.
6. Repeat steps 2 – 4 while watching cable to remove slack.
7. Check function of remote wheel lock. If wheel lock does not function properly, take the unit to Dealer for repairs.

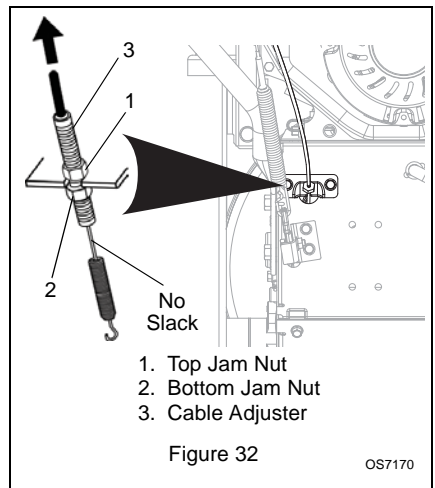

REMOTE DEFLECTOR CONTROL

(Figure 33)

Deflector must stay in selected position while throwing snow.

If deflector does not stay in set position:

1. Tighten nut beneath control panel to increase pressure on deflector control.

If deflector does not follow full range of travel:

1. Push deflector remote all the way forward.
2. Loosen adjusting nuts on cable support bracket underneath the control panel (Figure 33).
3. To adjust the deflector lower:
Slide cable down. Tighten bottom nut.
4. To adjust deflector higher:
Slide cable up. Tighten top nut.
5. Check travel and repeat adjustment as necessary.

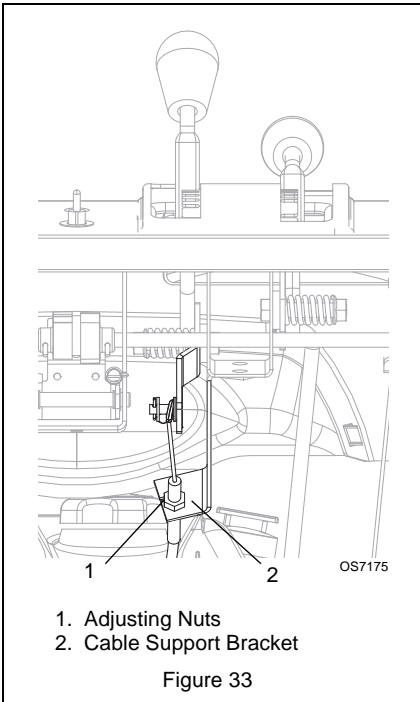

QUICK TURN CHUTE CONTROL (921017, 018)

(Figure 34)

If chute does not stay in position while throwing snow or if chute does not rotate freely, adjust the cable under the gear cover so the chute lock fingers engage or disengage the locking gear.

If chute does not stay in position:

Loosen the cable by loosening the rear adjustment nut, and then tightening the forward adjustment nut against the bracket until the lock arm engages the gear teeth (Figure 34).

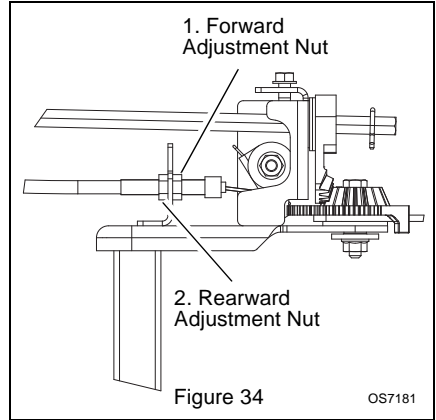

If chute does not rotate freely:

Tighten the cable by loosening the forward adjustment nut, and then tightening the rear adjustment nut against the bracket until all cable slack is removed (Figure 34).

DISCHARGE CHUTE (921013, 019, 022, 023, 031)

(Figure 35)

If discharge chute does not stay in position while operating, tighten nut on carriage bolt at pivot point to increase tension on spring.

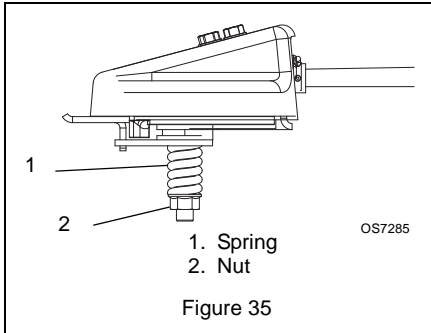

SPEED SELECTOR ADJUSTMENT

(Figure 36)

To adjust:

1. Disconnect adjustment pivot pin from speed selector lever by removing hairpin.
2. Place the speed selector on the control panel in the fastest forward speed position.
3. Turn the speed selector lever straight down towards the ground as far as it will go.
4. Thread the adjustment pivot pin along the shift rod until it aligns with the mating hole on the speed selector lever. Insert the pivot pin into hole.
5. Secure adjustment pivot pin with hairpin.
6. Make sure the speed selector shifts into each speed position.
7. Check forward and reverse speeds:
 - a. Start unit.
 - b. Shift speed selector into the first forward speed.
 - c. Engage the traction clutch. Unit should move forward.
 - d. Stop unit.
 - e. Shift speed selector into first reverse speed.
 - f. Engage the traction clutch. Unit should move backward with equal speed as first forward.
 - g. Shut off unit.
8. Adjust pivot pin on the shift rod as necessary so unit travels forward when speed selector is in first forward position and travels backward when speed selector is in first reverse position.
9. Connect the pivot pin to the speed selector arm with the hardware removed in step 1.

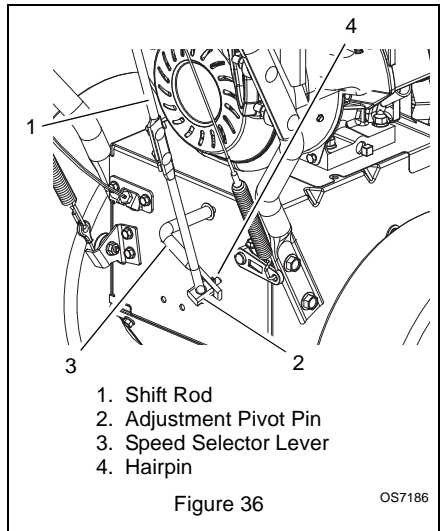

ATTACHMENT CLUTCH/BRAKE ADJUSTMENT

(Figures 37 and 38)



IMPORTANT: IMPROPER ADJUSTMENT could result in unexpected movement of auger and impeller causing death or serious injury. Auger/Impeller must stop within 5 seconds when Attachment Clutch/Impeller Brake lever is released.

Remove Attachment Cable Slack

1. Shut off engine, remove key, disconnect spark plug wire and allow unit to cool completely.
2. Loosen hardware securing belt cover to unit.

NOTE: DO NOT completely remove the hardware from unit.

3. Remove belt cover.
4. Loosen jam nut on cable adjustment barrel, and then turn the adjustment barrel up or down to lengthen or shorten cable and remove all cable slack (Figure 37).

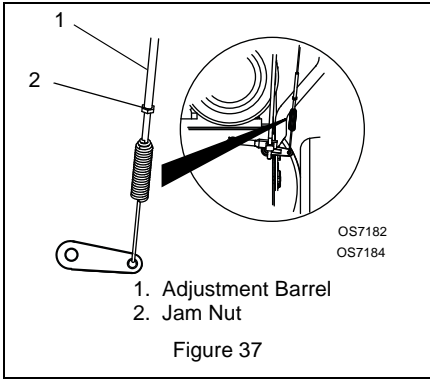

5. With the attachment clutch disengaged, check that the attachment idler arm lightly touches the frame (Figure 38).
6. Tighten jam nut on the adjustment barrel.

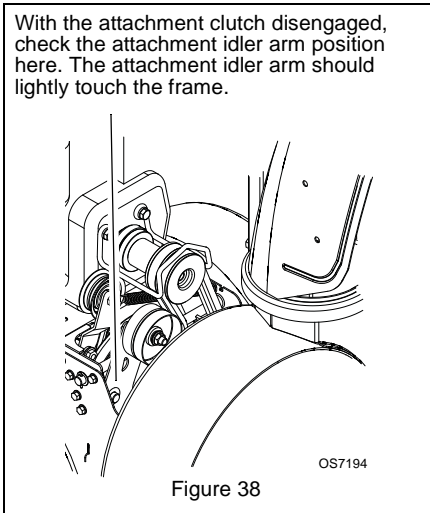

Check Attachment Idler Arm Roller Clearance

(Figure 39)

1. Place the unit into the service position. Remove the bottom cover.
2. With the clutch lever engaged, check the clearance between the frame and plastic roller on the lower end of the attachment idler arm.
 - If roller is 1/2 – 7/8 in. (12.7 – 22.2 mm) from frame, no further adjustment is needed.
 - If roller is more than 7/8 in. (22.2 mm) from frame, loosen idler adjustment nut and move idler away from the belt, tighten adjustment nut and recheck roller clearance.

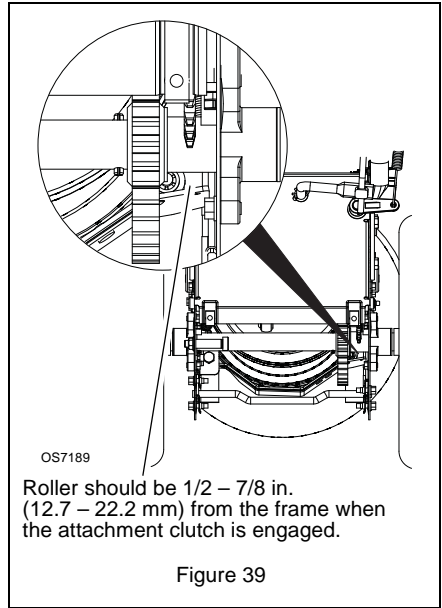

Check Attachment Brake

(Figure 40)

1. With the clutch lever disengaged, brake pad must contact attachment belts. With clutch lever engaged, brake pad must be more than 1/16 in. (1.6 mm) from belts. If there is more than 1/16 in. (1.6 mm) gap, go to *Check Belt Finger Clearance* on page 32. If there is less than 1/16 in. (1.6 mm) gap, go to step 2.

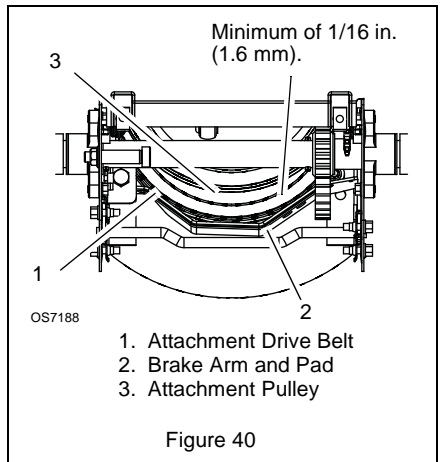

2. If there is less than 1/16 in. (1.6 mm) gap between brake pad and belts loosen idler adjustment nut, and move idler away from belt. Position idler to achieve a 1/16 in. (1.6 mm) minimum brake pad gap and a 1/2 in. (12.7 mm) minimum gap between the plastic roller and the frame.

IMPORTANT: If adjustments cannot be brought into specified ranges see your Dealer for repairs.

Check Belt Finger Clearance

1. With clutch lever engaged, the belt finger located opposite the belt idler must be less than 1/8 in. (3 mm) from belts, but not touching the belts (Figure 41).

To adjust belt finger, loosen the bolts and move the finger to the proper position. Tighten the bolts and recheck the belt finger clearance.

2. Replace the belt cover and tighten hardware.

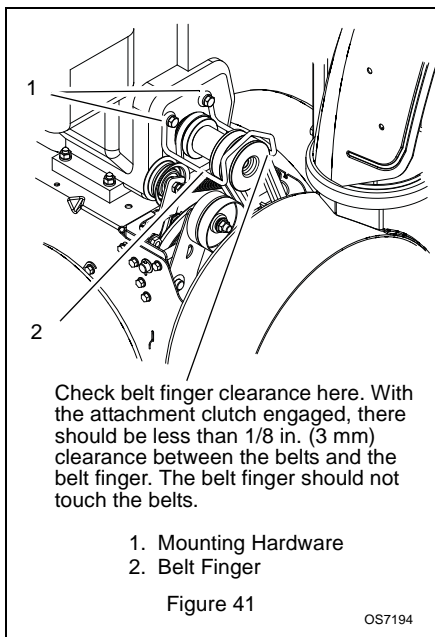

ATTACHMENT DRIVE BELT REPLACEMENT

Remove old attachment drive belts:

1. Shut off engine, remove key, disconnect spark plug wire and allow unit to cool completely.
2. Loosen hardware securing belt cover to unit.

NOTE: DO NOT completely remove the hardware from unit.

3. Remove belt cover.
4. **921017, 018** – Remove chute gear cover (Figure 42).
5. Rotate discharge chute all the way to the left (as viewed from the operator's position).
6. **921017, 018** – Remove hairpin under the control panel connecting the discharge chute rod to the chute rotation lever and slide the discharge chute rod forward.
- 921013, 022, 023, 031** – Remove spring clip from chute crank and separate.

IMPORTANT: Disconnect chute lock cable and deflector cable, if equipped.

7. Remove belt finger (Figure 41).
8. Remove attachment drive belt from engine sheave (it may be necessary to turn engine sheave using recoil starter handle).

IMPORTANT: To avoid bending bottom cover when tipping unit apart, support handlebars firmly or tip unit up on housing and remove bottom cover by removing six cap screws before separating unit.

9. Support Sno-Thro frame and housing.



CAUTION: Always support Sno-Thro frame and blower housing when loosening the cap screws holding them together. Never loosen cap screws while unit is in service position.

10. Remove hex bolts securing housing to frame (two on each side). Tip housing and frame apart on pivot pin (Figure 42).
11. Remove attachment drive belts from attachment pulley (hold brake away from belt).

921013, 022, 023, 031

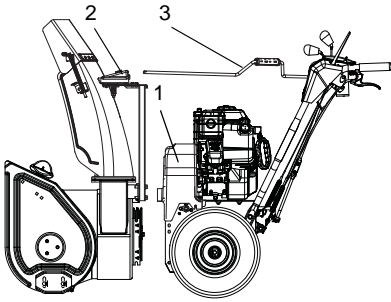

921017, 018

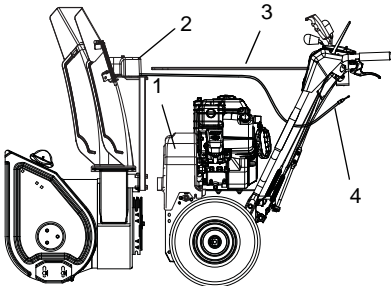

- 1. Belt Cover
- 2. Chute Gear Cover
- 3. Discharge Chute Rod
- 4. Chute Lock Cable

Figure 42

Install new attachment drive belts:

- 1. Place new attachment belts onto attachment pulley.

NOTE: Holding down the attachment clutch lever will make it easier to reconnect the housing and frame.

- 2. Tip housing and frame back together and secure with hex bolts.
- 3. Place belts onto engine sheave.
- 4. Reposition and secure belt finger.

IMPORTANT: With clutch lever engaged, belt finger on the side opposite the belt idler should be less than 1/8 in. (3 mm) from belt, but not touching the belt. Adjust belt finger as necessary.

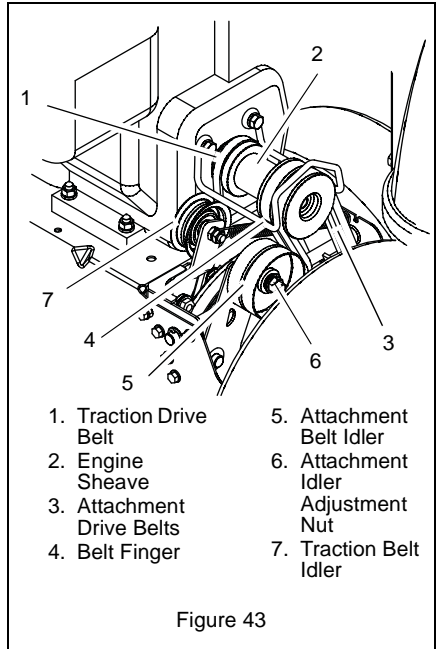

- 1. Traction Drive Belt
- 2. Engine Sheave
- 3. Attachment Drive Belts
- 4. Belt Finger
- 5. Attachment Belt Idler
- 6. Attachment Idler Adjustment Nut
- 7. Traction Belt Idler

Figure 43

- 5. Check adjustment. See *Attachment Clutch/Brake Adjustment* on page 30.



WARNING: AUGER / IMPELLER MUST STOP within 5 seconds when attachment clutch lever is released or unit damage or serious injury may result.

- 6. Reconnect chute crank and secure with spring clip (921013, 022, 023, 031) or hairpin (921017, 018).

IMPORTANT: Reconnect chute lock cable and deflector cable (if equipped).

- 7. Replace belt cover and tighten hardware.

TRACTION DRIVE BELT REPLACEMENT

NOTE: Replacement will be easier with housing and frame tipped apart and bottom cover off.

- 1. Remove attachment drive belts (see *Attachment Drive Belt Replacement* on page 32).
- 2. To gain belt clearance, remove swing gate spacer and slide drive plate over so that finger clears stop hole in frame and can swing past it (Figure 44).
- 3. Pull idler away from traction drive belt and remove belt from idler pulley, engine sheave and driven pulley (it may be necessary to turn engine pulley using recoil handle).

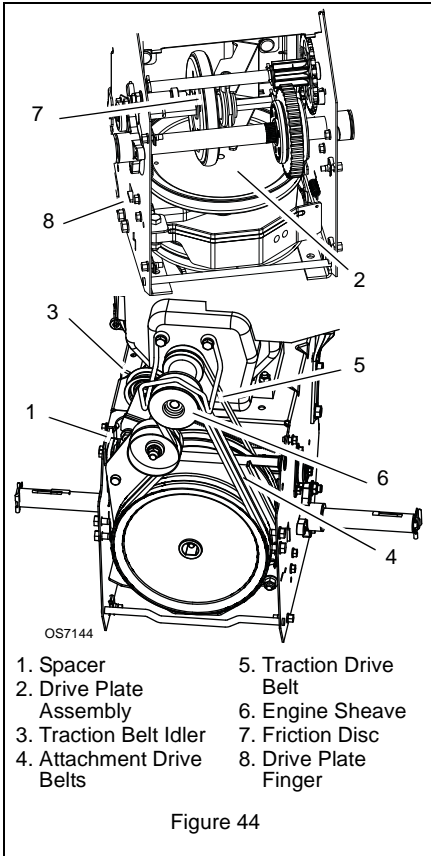

Figure 44

4. Install new traction drive belt onto driven pulley and engine sheave.
5. Swing drive plate toward friction disc until finger lines up with stop hole in frame. Slide drive plate over, inserting finger into stop hole. Reinstall drive plate spacer.

NOTE: Make sure the drive plate assembly return spring remains connected to the frame and nylon bushing is in drive plate pivot hole.

6. Replace attachment drive belt (See *Attachment Drive Belt Replacement* on page 32).

FRICION DISC REPLACEMENT

1. Shut off engine, remove key, disconnect spark plug wire and allow unit to cool completely.
2. Place unit into service position on a level surface.
3. Remove both wheels.
4. Remove bottom cover by removing six hex bolts.
5. Disconnect pivot pin from the speed selector arm. Save the hardware for reinstallation.
6. Remove spring clip nearest drive sprocket from hex shaft.
7. Remove left bearing flange from frame.
8. Slide hex shaft to the left to remove pinion sprocket and friction disc assembly from hex shaft.

NOTE: Be sure to save washers between bearing and sliding fork for re-assembly.

9. Remove friction disc assembly from frame.
10. Remove three screws holding friction disc to carrier bearing.
11. Remove old friction disc. Put the new friction disc in place, cup side to carrier bearing.
12. Reinstall three screws onto new friction disc and carrier bearing. Torque to 5 – 6 lbf-ft (22.2 – 26.7 N•m).
13. Insert new friction disc assembly into frame. Install washers onto carrier bearing and slide into speed selector arm.
14. Slide hex shaft through new friction disc assembly. Install pinion sprocket onto hex shaft and slide shaft into right bearing.
15. Install left bearing using hardware removed in step 7.
16. Reinstall clip pin into hex shaft.
17. Connect pivot pin to speed selector arm (see *Discharge Chute* on page 30).
18. Replace bottom cover.
19. Install wheels.
20. Return unit to upright position.
21. Connect spark plug wire to spark plug.

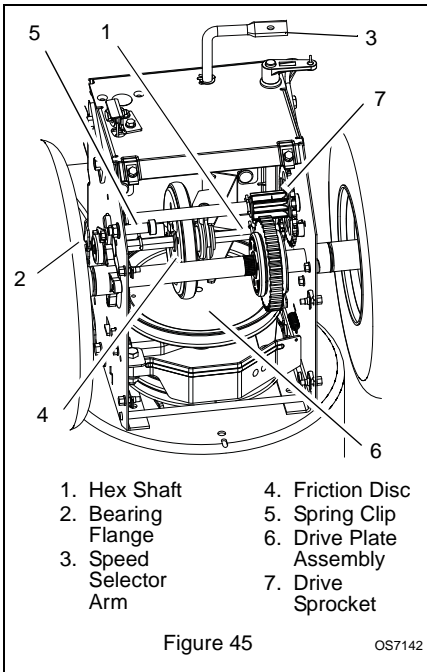

TRACK TENSION ADJUSTMENT (921023)

(Figure 46 and 47)

Check the track tension by applying pressure on the track midway between the upper and rear track rollers. Deflection should be approximately 3/8 in. (9.6 mm) (Figure 46). If deflection is excessive, tighten the track tension.

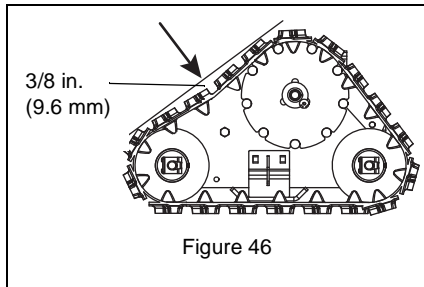

If unit pulls to the left or right when a straight path is desired adjust the track tension. If the unit is pulling to the left, tighten the left track adjuster. If the unit is pulling to the right, tighten the right track adjuster.

To adjust (Figure 47):

1. Tighten the adjuster nut to tighten the track tension.
Loosen the adjuster nut to reduce track tension.

2. Check that unit tracks straight with no pulling to either side.

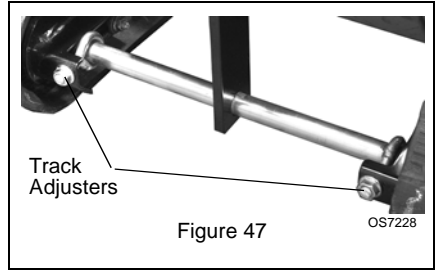

HEIGHT ADJUSTER CABLE ADJUSTMENT (921023)

(Figure 48)

1. Make sure that height adjustment lock finger is fully engaged (Figure 48).
2. Loosen jam nut on cable adjustment barrel.
3. Turn the adjustment barrel to remove all cable slack and bring the overtravel arm until it makes slight contact with the right end of the slot in the height adjuster lock finger.
4. Tighten the jam nuts.

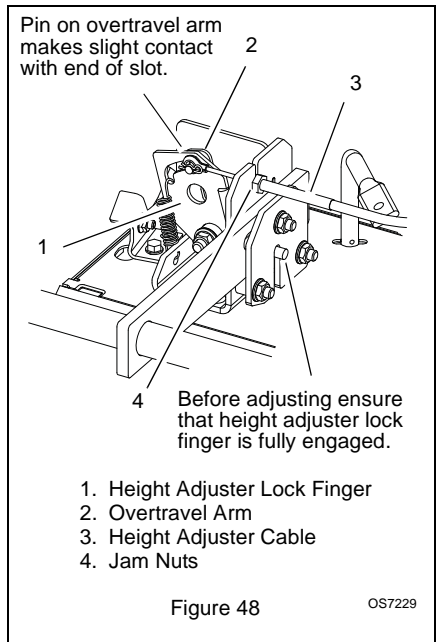

STORAGE



WARNING: AVOID INJURY. Read and understand the entire *Safety* section before proceeding.

SHORT TERM

IMPORTANT: NEVER spray unit with high pressure water or store unit outdoors.

Run with attachment clutch engaged a few minutes after each use to free unit of any loose or melting snow.

Close fuel shut-off valve.

Inspect unit for visible signs of wear, breakage or damage.

Keep all nuts, bolts and screws properly tightened and know unit is in safe working condition.

Store unit in a cool, dry protected area.

LONG TERM

Clean unit thoroughly with mild soap and low pressure water and lubricate (see *MAINTENANCE* on page 24). Touch up all scratched painted surfaces.

Remove weight from wheels by putting blocks under frame or axle.

FUEL SYSTEM

Gasoline left in the fuel system for extended periods without a stabilizer will deteriorate, resulting in gum deposits in the system.

These deposits can damage the carburetor and the fuel hoses, filter and tank. Prevent deposits from forming in the fuel system during storage by adding a quality fuel stabilizer to the fuel. Follow the recommended mix ratio found on the fuel stabilizer container.

IMPORTANT: NEVER store the engine with fuel in the fuel tank inside of a building with potential sources of ignition.

Add Fuel Stabilizer

1. Turn the fuel valve off while engine is running and allow the engine to run until it stops. Turn engine OFF when it begins surging to avoid engine damage.
2. Add fuel stabilizer, following the manufacturer's instructions.
3. Turn fuel valve on after adding fuel stabilizer.
4. Re-start engine.
5. Run the engine outdoors for 1 minute to be sure that treated gasoline has replaced the untreated gasoline in the carburetor.
6. Slow the engine to an idle speed.
7. Repeat step 1 above.

SERVICE PARTS

Order the following parts through your Dealer:

Part No.	Description
00036800	Ariens Hi-Temp Grease (3, 3 oz cartridges)
00592900	Fuel Stabilizer (4 oz.)
21534100	Spark Plug
07200514	Auger Belt (2)
07200111	Traction Belt
00170800	Friction Disc
52100100	Shear Bolt Kit
06400920	Gear Case Filler Plug Seal Washer

ACCESSORIES

See your authorized Ariens dealer to add the additional accessories available to your Sno-Thro.

Part No.	Description
72406500	Front Weight Kit
72406900	Slicer Bar
72600300	Composite Skid Shoes
72600200	Cover
72408000	Snow Cab

TROUBLESHOOTING

PROBLEM	PROBABLE CAUSE	CORRECTION
Engine will not crank/start.	<ol style="list-style-type: none"> 1. Fuel tank is empty. 2. Fuel shut-off valve closed. 3. Build up of dirt and residue around governor/carburetor. 4. Key Switch not in run position. 5. Electric starter not functioning. 	<ol style="list-style-type: none"> 1. Fill fuel tank (see <i>FILLING FUEL TANK</i> on page 21). 2. Open fuel shut-off valve. 3. Clean area around governor/carburetor. 4. Put Key Switch into run position. 5. Check for a bad starter or connections.
Engine stops.	<ol style="list-style-type: none"> 1. Out of fuel. 2. Fuel shut-off valve closed. 3. Mechanical jam in blower rake or impeller. 4. Polluted fuel supply. 5. Faulty spark plug. 6. Plugged fuel cap vent. 	<ol style="list-style-type: none"> 1. Fill fuel tank (see <i>FILLING FUEL TANK</i> on page 21). 2. Open fuel shut-off valve. 3. Turn off engine, remove key, and wait for all moving parts to stop. Check for and remove obstruction and repair before restart. 4. Replace with clean fuel. 5. Replace or clean spark plug. 6. Replace fuel cap.
Engine problems.	<ol style="list-style-type: none"> 1. See Engine Manual. 	<ol style="list-style-type: none"> 1. See Engine Manual.
Does not operate in Forward / Reverse.	<ol style="list-style-type: none"> 1. Friction disc worn out. 2. Traction belt not functioning. 3. Speed selector not adjusted properly. 	<ol style="list-style-type: none"> 1. Repair or replace friction disc. See <i>Friction Disc Replacement</i> on page 34. 2. Repair or replace traction drive belt. See <i>Friction Disc Replacement</i> on page 34. 3. Adjust speed selector. See <i>Speed Selector Adjustment</i> on page 30.
Small rubber beads collect in frame	<ol style="list-style-type: none"> 1. Friction disc wear. 	<ol style="list-style-type: none"> 1. Normal friction disc wear. Chunks or large pieces of rubber mean friction disc should be checked and replaced as necessary.
Unit throws snow poorly or does not throw snow.	<ol style="list-style-type: none"> 1. Shear bolts broken. 2. Attachment clutch/brake not adjusted properly. 3. Auger is frozen in place. 4. Ice or debris is obstructing auger. 5. Attachment drive belts slipping, worn or damaged. 	<ol style="list-style-type: none"> 1. Replace shear bolts (see <i>Shear Bolts</i> on page 28). 2. Adjust attachment clutch/brake (see <i>Attachment Clutch/Brake Adjustment</i> on page 30). 3. Move unit to a warm place to thaw. 4. With the engine off and auger disengaged, check for obstructions and remove. 5. Adjust or replace attachment drive belts (see <i>Attachment Drive Belt Replacement</i> on page 32).

SPECIFICATIONS

Model Number	921013	921017	921018
Description	Deluxe 30	Deluxe 24 Platinum	Deluxe 30 Platinum
Engine			
Engine	Briggs & Stratton Polar Force 1450	Briggs & Stratton Polar Force 1150	Briggs & Stratton Polar Force 1650
Gross Torque* – lbf-ft (N•m)	14.5 (19.66)	11.5 (15.59)	16.5 (22.37)
*Engine output stated in gross torque per SAE J1940 as rated by engine manufacturer			
Displacement – in. (cc)	18.61 (305)	15.19 (249)	20.87 (342)
High Idle – RPM (min)	3600 ± 100		
Electric Start	120V		
Fuel Tank Capacity – qt (Liters)	3.2 (3.0)	2.9 (2.74)	3.2 (3.0)
Chute			
Chute Rotation Angle	200°		
Rotation Control	2.5X Quick Turn	Quick Turn	
Deflector Control	Remote		
Auger			
Snow Clearing Width – in. (cm)	30 (76.2)	24 (61.0)	30 (76.2)
Gearcase	Cast Iron		
Auger Diameter – in. (cm)	14 (35.6)		
Impeller			
Impeller Diameter – in. (cm)	14 (35.6)		
Impeller Speed (RPM)	1010		
Impeller Tip Speed – ft/sec (m/sec)	3702 (1128)		
Drive			
Blower Drive	Dual HA Belts		
Drive	Disc-O-Matic™		
Speeds	6 Forward and 2 Reverse		
Axle Control	Remote Axle Lock	Automatic Traction Control	
Pneumatic Tires – in. (cm)	15 x 5-6 (38 x 13-15) Directional		
Size and Weight			
Length – in. (cm)	57.91 (147.1)		
Height – in. (cm)	44.25 (112.4)		
Width – in. (cm)	32.4 (82.3)	26.4 (67.1)	32.4 (82.3)
Weight – lbs (Kg)	250 (113.4)	224 (101.6)	250 (113.4)

SPECIFICATIONS

Model Number	921022	921023	921031
Description	Deluxe 28	Deluxe Track 28	Deluxe 24
Engine			
Engine Model	Briggs & Stratton Polar Force 1150		
Gross Torque* – lbf-ft (N•m)	11.5 (15.59)		
*Engine output stated in gross torque per SAE J1940 as rated by engine manufacturer			
Displacement – in. (cc)	15.19 (249)		
High Idle – RPM (min)	3600 ± 100		
Electric Start	120V		
Fuel Tank Capacity – qt (Liters)	2.9 (2.74)		
Chute			
Chute Rotation Angle	200°		
Rotation Control	2.5X Quick Turn		
Deflector Control	Remote		
Auger			
Snow Clearing Width – in. (cm)	28 (71.1)		24 (61.0)
Gearcase	Cast Iron		
Auger Diameter – in. (cm)	14 (35.6)		
Impeller			
Impeller Diameter – in. (cm)	14 (35.6)		
Impeller Speed (RPM)	1010		
Impeller Tip Speed – ft/min (m/m)	3702 (1128)		
Drive			
Blower Drive	Dual HA Belts		
Drive	Disc-O-Matic™		
Speeds	6 Forward and 2 Reverse		
Axle Control	Remote Axle Lock	Solid Axle	Pin-Lock
Pneumatic Tires – in. (cm)	15 x 5-6 (38 x 13-15) Directional	5.5 (13.97) Directional Track Drive	15 x 5-6 (38 x 13-15) Directional
Size and Weight			
Length – in. (cm)	55.4 (140.7)	57.91 (147.1)	55.4 (140.7)
Height – in. (cm)	44.5 (113.3)	44.25 (112.4)	44.5 (113.3)
Width – in. (cm)	29.9 (75.9)	29.9 (75.9)	26.4 (67.1)
Weight – lbs (Kg)	220 (99.8)	274 (124.3)	213 (96.6)



Sno-Thro[®], Sno-Tek[®] and Chore Performing Equipment Limited Warranty

Ariens Company (Ariens) warrants to the **original purchaser** that Ariens, Gravely, Parker, and Countax brand chore performing equipment (including Sno-Thro[®] and Sno-Tek[®] equipment) purchased on or after 1/1/2011 will be free from defects in material and workmanship for the time period noted in the chart below. Equipment put to personal use around a single household or residence is considered "Consumer Use"; equipment put to any business use (agricultural, commercial, or industrial) or used at multiple locations is considered "Commercial Use." If any product is rented or leased, then the duration of these warranties shall be 90 days after the date of purchase.

An authorized Ariens dealer (Ariens brand products), Gravely dealer (Gravely brand products), Parker dealer (Parker brand products), or Countax dealer (Countax brand products) will repair any defect in material or workmanship, and repair or replace any defective part, subject to the conditions, limitations and exclusions set forth herein. Such repair or replacement will be free of charge (labor and parts) to the original purchaser except as noted below.

Warranty Code	Product Group	Warranty Period Consumer Use	Warranty Period Commercial Use
PA	Log Splitters, Brushes, String Trimmers, Edgers	3 Years	90 Days
PB	Professional Powered Brushes	3 Years	1 Year
PC	Tillers	2 Years	90 Days
PD	Vacuums, Blowers, Sweepers, Truck Loaders, Lawn Rakes, Sprayers, Aerators, etc.	1 Year	1 Year
SA	Professional Sno-Thro [®]	3 Years	1 Year
SB	Compact, Deluxe, Platinum, AMP [™] Sno-Thro [®]	3 Years	90 Days
SC	Sno-Tek [®]	2 Years	90 Days
UA	Utility Vehicles	1 Year	1 Year
N/A	Service (Replacement) Parts	90 Days (no labor)	90 Days (no labor)

Special Extensions

The chart below details special extensions to this warranty:

Warranty Code	Warranty Exception	Warranty Period	Use	Detail
SA	Cast Iron Auger Gear Case	5 Years	All	5 Years for all users including Commercial
SB	Cast Iron Auger Gear Case	5 Years	Consumer	5 Years for Consumer use; 1 Year for Commercial Use
SB	Batteries for AMP [™] Sno-Thro [®]	2 Years	Consumer	100% first year; prorated second year.

Exceptions and Limitations

The chart below details special exceptions to this warranty:

Warranty Code	Warranty Exception	Warranty Period	Use	Detail
All	Batteries	1 Year	All	Prorated
All	Belts, Muffler, Tires	None	Commercial	These components are not covered when used commercially.
All	Cloth, Plastic, and Rubber Components (Including Belts and Cables)	Maximum 2 Years	All	Warranty is limited to 2 years for consumer use. (1 year for warranty code "PD".) Except as noted above, these components are covered for defect, not for wear.
SA, SB, SC	Idlers	Maximum 2 Years	All	Warranty is limited on idlers to 2 years for consumer use.
All	Engines	See Engine Manufacturer's Warranty	All	Engines are covered by engine manufacturer's warranty. Refer to engine manufacturer's warranty statement.

Customer Responsibilities

Register the product immediately at the time of sale. If the dealer does not register the product, the customer must complete the product registration card in the literature package and return it to the Ariens Company, or register the unit online at www.ariens.com, www.gravely.com, www.countax.com, www.parkersweeper.com.

To obtain warranty service, the **original purchaser** must:

- Perform the maintenance and adjustments explained in the owner's manual.
- Promptly notify Ariens or an authorized Ariens, Gravely, Parker or Countax service representative of the need for warranty service.
- Transport the product to and from the place of warranty service at owner's expense.
- Have the warranty service performed by an authorized Ariens, Gravely, Parker or Countax service representative.

To Find an Authorized Service Representative:

In the U.S. and Canada:		
Use the dealer locator on our websites: www.ariens.com • www.gravely.com		
Or contact us by mail or by phone:		
In the U.S., Canada, Mexico, Caribbean, Central and South America:	In Europe, Asia, Africa or the Middle East:	In Australia or New Zealand:
Ariens Company 655 W. Ryan Street Brillion, WI 54110 Phone: (920) 756 - 4688 www.ariens.com	Countax Ltd, Countax House Great Haseley, Oxfordshire, OX44 7PF Phone: 0800 597 7777 www.countax.com	109-111 Abbot House Hallam, Victoria 3803 Australia Phone: (03) 9796 4244 1800 335 489 www.bynorm.com.au

Exclusions - Items Not Covered by This Warranty

- Parts that are not genuine Ariens, Gravely, Parker or Countax service parts are not covered by this warranty and may void the warranty.
- Damages resulting from the installation or use of any part, accessory, or attachment which is not approved by the Ariens Company for use with product(s) identified herein are not covered by this warranty.
- The following maintenance, service and replacement items are not covered by this warranty unless they are noted in the Limitations section above: lubricants, spark plugs, oil, oil filters, air filters, fuel filters, brake linings, brake arms, brake shoes, skid shoes, scraper blades, shear bolts, mower blades, mower vanes, brushes, headlights, light bulbs, knives, cutters.
- Any misuse, alteration, improper assembly, improper adjustment, neglect, or accident which requires repair is not covered by this warranty.
- **Use of gasoline blends exceeding 10% ethanol voids any and all warranties.**
- Products are designed to the specifications in the area that the product was originally distributed. Different areas may have significantly different legal and design requirements. This warranty is limited to the requirements in the area in which the unit was originally distributed. Ariens Company does not warrant this product to the requirements of any other area. Warranty service is limited to service within the area originally distributed.
- In countries other than the United States and Canada, contact the Ariens Company dealer for warranty policies that govern within your country. Rights may vary from country to country and within any one country.

Special Exclusions on Utility Vehicles

The following uses void the warranty terms on Utility Vehicles (Warranty Code UA):

- Renting or leasing the utility vehicle.
- Using the utility vehicle to tow or carry loads in excess of the limits specified in the owner/operator manual.
- Modifying the utility vehicle with parts and accessories that are not genuine or authorized Ariens or Gravely parts or accessories.
- Modifying the utility vehicle without express written authorization from the Ariens Company.
- Operating the utility vehicle when it has not been completely and properly assembled and pre-delivered by an authorized Gravely dealer.

Disclaimer

Ariens Company may from time to time change the design of its products. Nothing contained in this warranty shall be construed as obligating the Ariens Company to incorporate such design changes into previously manufactured products, nor shall such changes be construed as an admission that previous designs were defective.

LIMITATION OF REMEDY AND DAMAGES

Ariens Company's liability under this warranty, and under any implied warranty that may exist, is limited to repair of any defect in workmanship, and repair or replacement of any defective part. Ariens Company shall not be liable for incidental, special, or consequential damages (including lost profits). Some states do not allow the exclusion of incidental or consequential damages, so the above limitation or exclusion may not apply to you.

DISCLAIMER OF FURTHER WARRANTY

Ariens Company makes no warranty, express or implied, other than what is expressly made in this warranty. If the law of your state provides that an implied warranty of merchantability, or an implied warranty of fitness for particular purpose, or any other implied warranty, applies to Ariens Company, then any such implied warranty is limited to the duration of this warranty. Some states do not allow limitations on how long an implied warranty lasts, so the above limitation may not apply to you.

This warranty gives you specific legal rights, and you may also have other rights which vary from region to region.

CALIFORNIA AND EPA (UNITED STATES ENVIRONMENTAL PROTECTION AGENCY) EVAPORATIVE EMISSION CONTROL WARRANTY STATEMENT

YOUR WARRANTY RIGHTS AND OBLIGATIONS

The CARB (California Air Resources Board), the EPA, and Ariens Company are pleased to explain the evaporative emission control system's warranty on your 2011 model year small off-road equipment. In California, new equipment that uses small off-road engines must be designed, built, and equipped to meet the State's stringent anti-smog standards. Ariens Company must warrant the evaporative emission control system on your small off-road equipment for the period listed below provided there has been no abuse, neglect or improper maintenance of your equipment.

Your evaporative emission control system may include parts such as: fuel tanks, fuel lines, fuel caps, valves, canisters, filters, vapor hoses, clamps, connectors, and other associated components.

MANUFACTURER'S WARRANTY COVERAGE:

This evaporative emission control system is warranted for two years. If any evaporative emission-related part on your equipment is defective, the part will be repaired or replaced by Ariens Company.

OWNER'S WARRANTY RESPONSIBILITIES:

- As the small off-road equipment owner, you are responsible for the performance of the required maintenance listed in your Owner's Manual. Ariens Company recommends that you retain all receipts covering maintenance on your small off-road equipment, but Ariens Company cannot deny warranty solely for the lack of receipts.
- As the small off-road equipment owner, you should however be aware that the Ariens Company may deny you warranty coverage if your evaporative emission control system part has failed due to abuse, neglect, or improper maintenance or unapproved modifications.
- You are responsible for presenting your small off-road equipment to an authorized Ariens, Gravely, or Parker service representative as soon as the problem exists. The warranty repairs should be completed in a reasonable amount of time, not to exceed 30 days. If you have a question regarding your warranty coverage, you should contact Ariens Company Technical Service Center at 1-920-756-2141.

DEFECTS WARRANTY REQUIREMENTS:

- (a.) The warranty period begins on the date the small off-road equipment is delivered to an ultimate purchaser.
- (b.) General Evaporative Emissions Warranty Coverage. Ariens Company warrants to the ultimate purchaser and any subsequent owner that the evaporative emission control system when installed was:
 - (1.) Designed, built, and equipped so as to conform with all applicable EPA and CARB regulations; and
 - (2.) Free from defects in materials and workmanship that causes the failure of a warranted part for a period of two years.
- (c.) The warranty on evaporative emissions-related parts will be interpreted as follows:
 - (1.) Any warranted part that is not scheduled for replacement as required maintenance in the written instructions must be warranted for the warranty period defined in subsection (b)(2). If any such part fails during the period of warranty coverage, it must be repaired or replaced by the Ariens Company. Any such part repaired or replaced under the warranty must be warranted for a time not less than the remaining warranty period.
 - (2.) Any warranted part that is scheduled only for regular inspection in the written instructions must be warranted for the warranty period defined in subsection (b)(2). A statement in such written instructions to the effect of "repair or replace as necessary" will not reduce the period of warranty coverage. Any such part repaired or replaced under warranty must be warranted for a time not less than the remaining warranty period.
 - (3.) Any warranted part that is scheduled for replacement as required maintenance in the written instructions must be warranted for the period of time prior to the first scheduled replacement point for that part. If the part fails prior to the first scheduled replacement, the part must be repaired or replaced by the Ariens Company. Any such part repaired or replaced under warranty must be warranted for a time not less than the remainder of the period prior to the first scheduled replacement point for the part.

- (4.) Repair or replacement of any warranted part under the warranty provisions of this article must be performed at no charge to the owner at an authorized Ariens, Gravely, or Parker service representative.
- (5.) Notwithstanding the provisions of subsection (4) above, warranty services or repairs must be provided at authorized Ariens, Gravely, or Parker service representatives that are franchised to service the subject small off-road equipment.
- (6.) The owner must not be charged for diagnostic labor that leads to the determination that a warranted part is in fact defective, provided that such diagnostic work is performed at an authorized Ariens, Gravely, or Parker service representative.
- (7.) Throughout the evaporative emission control system's warranty period set out in subsection (b)(2), the Ariens Company must maintain a supply of warranted parts sufficient to meet the expected demand for such parts.
- (8.) Manufacturer-approved replacement parts must be used in the performance of any warranty maintenance or repairs and must be provided without charge to the owner. Such use will not reduce the warranty obligations of the manufacturer issuing the warranty.
- (9.) The use of any add-on or modified parts will be grounds for disallowing a warranty claim made in accordance with this article. The manufacturer issuing the warranty will not be liable under this Article to warrant failures of warranted parts caused by the use of an add-on or modified part.

Evaporative Emission Warranty Parts List

The following parts are considered emission-related components for evaporative emissions:

- Fuel Tank, Fuel Cap and Tether
- Fuel Line, Fuel Line Fittings, Clamps*
- Pressure Relief Valves, Control Valves*
- Control Solenoids*, Electronic Controls*
- Vacuum Control Diaphragms*
- Control Cables*, Control Linkages*
- Purge Valves
- Vapor Hoses, Liquid/Vapor Separator
- Carbon Canister, Canister Mounting Brackets
- Carburetor Purge Port Connector

* As related to the evaporative emission control system

Disclaimer

New equipment sold in the state of California that uses small off-road engines must be exclusively certified and appropriately labeled for sale in California. Some equipment covered by this Owner's Manual may not be certified for sale in California and the presence of the preceding CARB and EPA Warranty Statement does not by its existence indicate which, if any, of the equipment covered by this Owner's Manual may be sold in California.

Some equipment covered by this Owner's Manual may have been manufactured prior to certain affectivity dates requiring the inclusion of evaporative emission control systems. Therefore some equipment covered by this Owner's Manual may not include the evaporative emission control systems referred to in the preceding CARB and EPA Warranty Statement.



THE KING OF SNOW®

Ariens
655 West Ryan Street
Brillion, WI 54110-1072
920-756-4688
www.ariens.com

See your local dealer for these useful accessories:



Sno-Thro® Cover

*Protect your investment. Available
in two sizes.*

*Drift Cutter Kit
Helps your Sno-Thro® tackle
drifting and packed snow.*



*Protective Floor Mat
Protects floor from rust, dirt and
snow melt.*

*Non-abrasive Skid Shoes
Protect decorative surfaces from
scratching and marring.*



*Please see your local dealer for accessory fit up and installation.
Visit www.ariens.com for more information on all of our great accessories.*



WARNING



The engine exhaust from this product contains chemicals known to the State of California to cause cancer, birth defects or other reproductive harm.

An *Ariens* Company Brand