



Zoom

Parts Manual

Models

915131 – Zoom 34
915141 - Zoom 42
915143 - Zoom 50
915151 - Zoom 34 Carb
915155 - Zoom 42 Carb



THE MANUAL

Before you operate your unit, carefully and completely read manuals supplied with the unit. The contents will provide you with an understanding of safety instructions and controls during normal operation and maintenance.

For your safety and the safety of others always read, understand, and follow all DANGER, WARNING, and CAUTION messages found in manuals and on safety decals.

Hardware descriptions are given in decimals.

Decimals to Fractions			
.063	1/16	.563	9/16
.125	1/8	.625	5/8
.188	3/16	.688	11/16
.250	1/4	.750	3/4
.313	5/16	.813	13/16
.375	3/8	.875	7/8
.438	7/16	.938	15/16
.500	1/2	1.00	1

SERVICE AND REPLACEMENT PARTS

When ordering replacement parts or making service inquiries, know the Model and Serial numbers of your unit and engine.

Numbers are located on the product registration card in the unit literature package. They are printed on a serial number label, located on the frame of your unit.

• Record Unit Model and Serial numbers here:

• Record Engine Model and Serial numbers here:

UNAUTHORIZED REPLACEMENT PARTS

Use only Ariens replacement parts. The replacement of any part on this vehicle with anything other than an Ariens authorized replacement part may adversely affect the performance, durability, or safety of this unit and may void the warranty. Ariens disclaims liability for any claims or damages, whether warranty, property damage, personal injury or death arising out of the use of unauthorized replacement parts.

PRODUCT REGISTRATION

The Ariens dealer must register the product at the time of purchase. Registering the product will help the company process warranty claims or contact you with the latest service information. All claims meeting requirements during the limited warranty period will be honored, whether or not the product registration card is returned. Keep a proof of purchase if you do not register your unit.

Customer Note: If Dealer does not register your product, please fill out, sign and return the product registration card to Ariens or go to www.ariens.com.

YOUR SATISFACTION IS IMPORTANT

Questions? Please follow these helpful steps:

1. Refer to the manuals supplied with your unit.
They will guide you through safe and proper operation and maintenance.
They contain specifications on your unit.
If your questions are not answered in these manuals, go to step number two.
2. Contact Your Dealer.
Our dealers will be happy to supply any service or advice required to keep your unit operating at peak efficiency.
A factory trained staff is available to support your equipment needs. They stock genuine Ariens parts and lubricants manufactured with the same precision and skill as the original.
If your questions are not resolved by the support staff, ask for the manager or owner.
When contacting your Dealer supply your model and serial numbers.

TO SPEED PARTS ORDERING:

1. Know the model and serial numbers of your unit.
2. Know the part number required.
3. Know the quantity required.
4. Know the part description.

MODELS

Domestic

Model 915131 (Zoom 34)

Briggs & Stratton with 34" Mower
Serial No. 010000 and up

Model 915141 (Zoom 42)

Briggs & Stratton with 42" Mower
Serial No. 000101 and up

Model 915143 (Zoom 50)

Kawasaki with 50" Mower
Serial No. 000101 and up

Model 915151 (Zoom 34 Carb LVE)

Briggs & Stratton with 34" Mower
Serial No. 000101 and up

Model 915155 (Zoom 42 Carb LVE)

Briggs & Stratton with 42" Mower
Serial No. 000101 and up

TABLE OF CONTENTS

DECALS

Decals 4

MAIN FRAME AND TRANSAXLES

Frame, Hood, Footrest, Caster and Tires 6

Seat and Support 10

Transaxle, Dump Valves and Rear Wheels 12

OPERATOR CONTROLS

Parking Brake 16

Steering Controls 18

FUEL TANKS AND ENGINE

Engine, Exhaust, Belt and Idlers 20

Fuel Tank 22

ELECTRICAL SYSTEM

Continuity Diagrams 23

Electrical System 24

Wiring Diagrams 26

MOWER DECKS

Mower Deck Lift 28

Mower Deck, Belt and Idlers 30

Belt Covers and Blades 34

DECALS-SAFETY

Model 915131, 141, 143, 151, 155

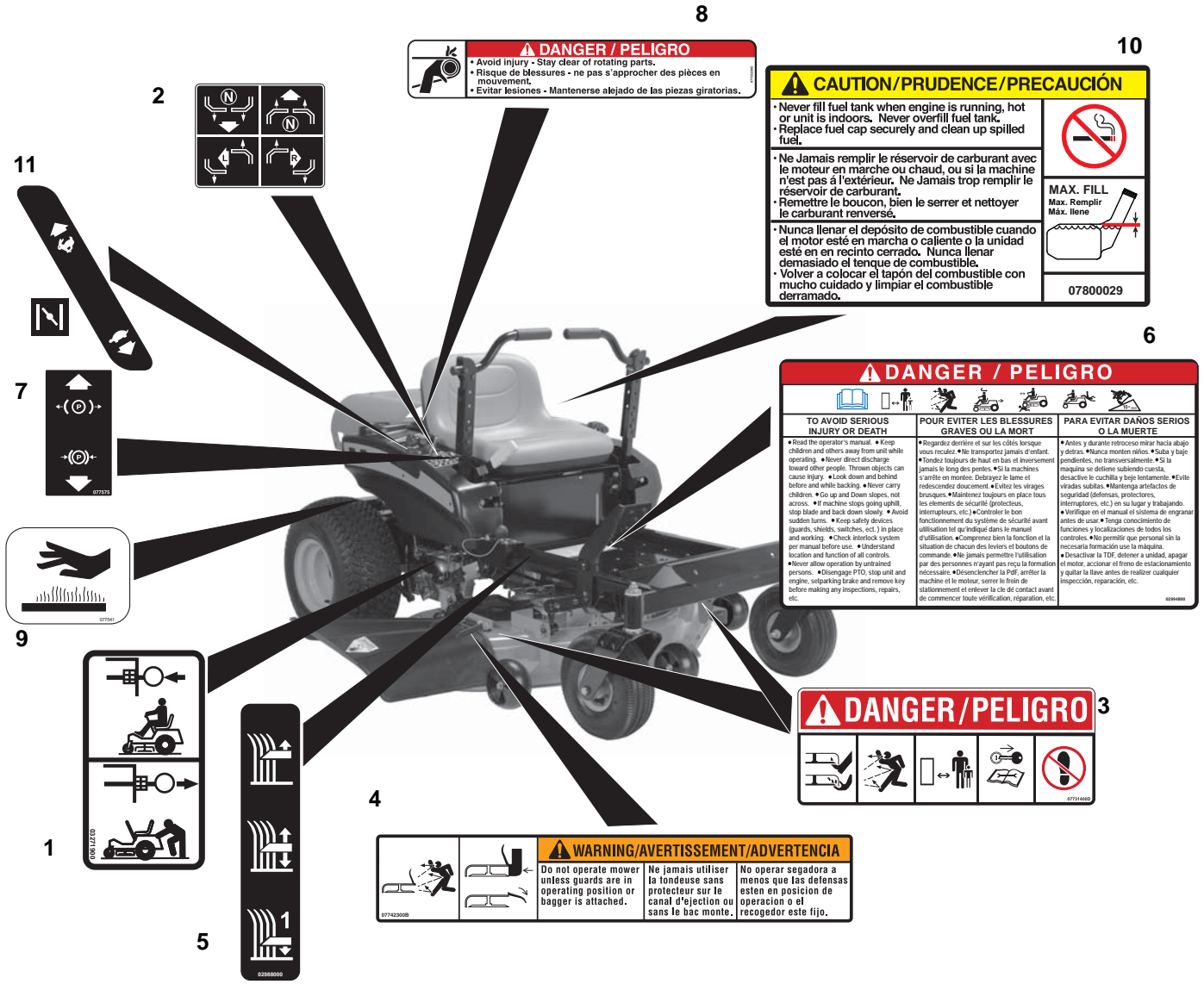

Item	Part No.	Qty.	Description
1	03271900	2	Decal, Transmission Disconnect
2	07757600	1	Decal, Instructional Steering
3	07731400	2	Decal, Mower Pan Head Danger
4	07742300	1	Decal, Warning
5	02988000	1	Decal, Cut Height
6	02994800	1	Decal, Bilingual Danger
7	07757500	1	Decal, Parking Brake Lever
8	07735200	1	Decal, Danger
9	07754100	1	Decal, Hot Surface
10	07800029	1	Decal, Fuel Warning
11	05301400	1	Decal, Control

DECALS-STYLE

Model 915131, 141, 143, 151, 155



PE0250

Item	Part No.	Qty.	Description
1	07800001	2	Decal, Ariens Jewel
2	07800206	1	Decal, Zoom 34 (131, 151)
	07800207	1	Decal, Zoom 42 (141, 155)
	07800208	1	Decal, Zoom 50 (143)
3	07800224	1	Decal, Ariens Made in America
4	07800203	1	Decal, Ariens Domed Jewel
5	07800033	1	Decal, Foot Pedal Lift
6	07800035	1	Decal, Powered By B&S (131, 141, 151, 155)
	07800023	1	Decal, Powered By Kawasaki (143)
7	07800034	1	Decal, Deck Size 34" (131, 151)
8	07800111	1	Decal, 13hp (131, 151)
	07800231	1	Decal, 16hp (141, 155)

FRAME, HOOD, FENDERS, CASTERS AND TIRES

Model 915131 (SN 010000 to 010500), 151, 155

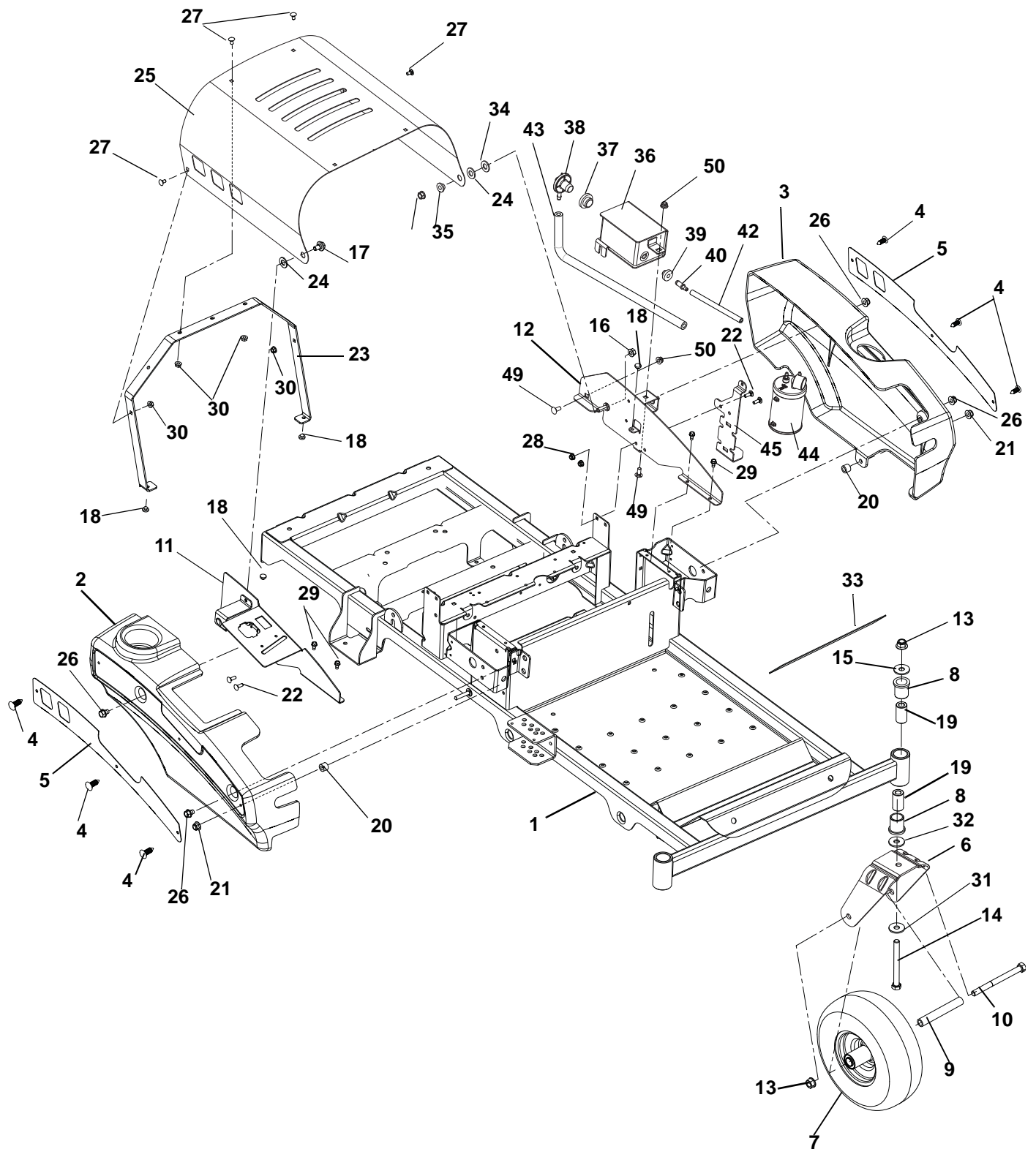

FRAME, HOOD, FENDERS, CASTERS AND TIRES

Model 915131 (SN 010000 to 010500), 151, 155

Item	Part No.	Qty.	Description
1	03896851	1	Weldment, Frame
2	03768600	1	Fender, Right Hand
3	03768700	1	Fender, Left Hand
4	07500125	6	Rivet, Nylon
5	03769059	2	Plate, Fender
6	03744751	2	Fork, Caster
7	07100801	2	Wheel/Tire Assembly, 11.0 x 4.0 x 5.0
8	05500934	4	Bushing, Flange 1.00 x 1.25 x 1.50 x 1.50
9	00278500	2	Spacer, Wheel
10	05964400	2	Bolt, Hex .50-13 x 6.50 Grade 5
11	04176851	1	Weldment, Fender Mount Right Hand
12	03768951	1	Weldment, Fender Mount Left Hand
13	06543600	4	Nut, Locking-Top-Flange .50-13
14	05962200	2	Bolt, Hex .50-13 x 5.00 Grade 5
15	06436400	2	Washer, Flat Steel .511 x 1.441 x .125
16	06542000	4	Nut, Locking-Top-Flange .38-16
17	07056700	1	Bolt, Shoulder .375-16 x .135
18	07503100	4	Bumper Grommet .125 x .250 Diameter
19	00363100	4	Spacer, Caster
20	08553700	2	Bushing, Sleeve .391 x .688 x .52
21	06545500	2	Nut, .38-16 Nyloc Flange
22	06219900	4	Bolt, Round Head Square Neck .25-20 x .75 Grade 5
23	03766559	1	Hood Brace
24	06443300	2	Washer, Flat-Nylon .52 x 1.00 x .08
25	04085659	1	Hood, Zoom
26	07412900	4	Screw, Tapping .38-16 x .50
27	06220600	5	Bolt, Round Head Square Neck .25-20 x .50 Grade 5
28	06500012	4	Nut, .25-20 Nyloc Flange
29	07412000	4	Screw, Tapping .25-20 x .50 Hex Washer Head Thread
30	06543500	5	Nut, Locking Top Flange .25-20
31	06445000	2	Washer-Flat-Steel .515 x 1.625 x .250
32	06441800	2	Washer-Flat-Steel .518 x 2.0 x .105
33	03833800	2	Grip, Adhesive (1" x 16" BLK)
34	06441900	1	Washer, Flat Steel .531 x 1.06 x .095
35	05500435	1	Bushing, Flange .385 x .500 x .875 x .406
36	04180751	1	Tank, Zoom Fuel Expansion (151, 155)
37	04082700	1	Grommet, Remote Vent Nitrile (151, 155)
38	04068900	1	Valve, Fuel Roll Over (151, 155)
39	07511400	1	Bushing, Flange .375 x 1.062 x .625 R (151, 155)
40	04182300	1	Fitting, Straight Fuel (151, 155)
41	03278800	6	Clamp, Fuel Line (151, 155)
42	03278100	7"	Hose, .25 Low-Perm Bulk Gas (151, 155)
43	03278100	13.5"	Hose, .25 Low-Perm Bulk Gas (151, 155)
44	04082500	1	Carbon Canister, 300CC (151, 155)
45	04086551	1	Bracket, Mount, Canister BBZ (151, 155)
46	04102900	2	Plastic Tie Strap Large (151, 155)
47	04097700	2	Clamp, Hose Spring .188 (151, 155)
48	03375900	36"	Hose, .188 Low-Perm Bulk Gas (151, 155)
49	06215700	2	Bolt, Round Head Square Neck .31-18 x .75 Grade 5
50	06543100	2	Nut, Locking Top Flange .31-18

FRAME, HOOD, FENDERS, CASTERS AND TIRES

Model 915131 (SN 010501 and up), 141, 143

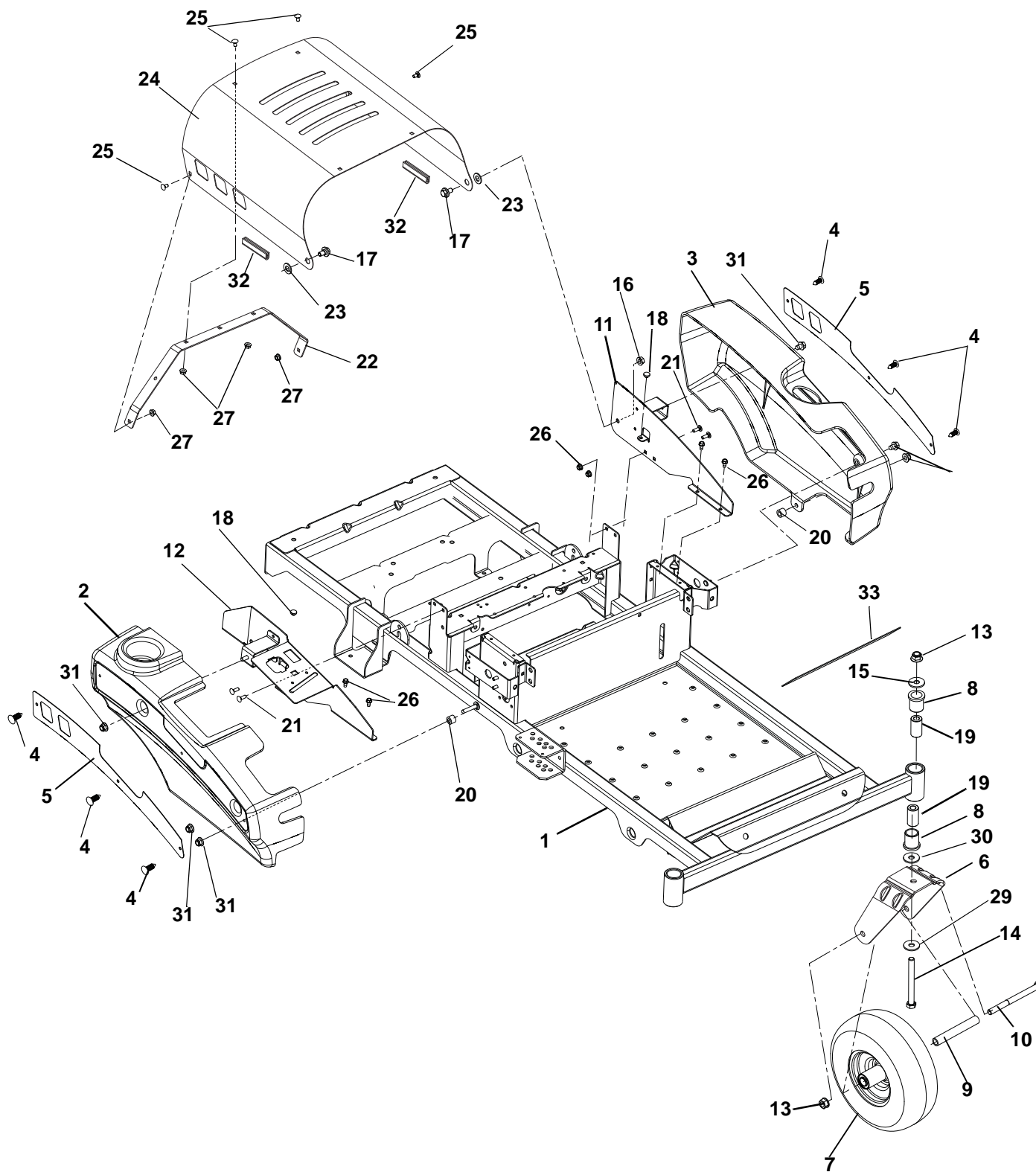

FRAME, HOOD, FENDERS, CASTERS AND TIRES

Model 915131 (SN 010501 and up), 141, 143

Item	Part No.	Qty.	Description
1	03896851	1	Weldment, Frame
2	03768600	1	Fender, Right Hand
3	03768700	1	Fender, Left Hand
4	07500125	6	Rivet, Nylon
5	03769059	2	Plate, Fender
6	03744751	2	Fork, Caster
7	07100801	2	Wheel/Tire Assembly, 11.0 x 4.0 x 5.0
8	05500934	4	Bushing, Flange 1.00 x 1.25 x 1.50 x 1.50
9	00278500	2	Spacer, Wheel
10	05964400	2	Bolt, Hex .50-13 x 6.50 Grade 5
11	04039951	1	Weldment, Fender Mount Right Hand
12	04040751	1	Weldment, Fender Mount Left Hand
13	06543600	4	Nut, Locking-Top-Flange .50-13
14	05962200	2	Bolt, Hex .50-13 x 5.00 Grade 5
15	06436400	2	Washer, Flat Steel .511 x 1.441 x .125
16	06542000	4	Nut, Locking-Top-Flange .38-16
17	07056700	2	Bolt, Shoulder .375-16 x .135
18	07503100	2	Bumper Grommet .125 x .250 Diameter
19	00363100	4	Spacer, Caster
20	08553700	2	Bushing, Sleeve .391 x .688 x .52
21	06219900	4	Bolt, Round Head Square Neck .25-20 x .75 Grade 5
22	03909259	1	Hood Brace
23	06443300	2	Washer, Flat-Nylon .52 x 1.00 x .08
24	03872259	1	Hood, Zoom
25	03872259	4	Bolt, Round Head Square Neck .25-20 x .50 Grade 5
26	06500012	4	Nut, Locking Top Flange .25-20
27	07412000	4	Screw, Tapping .25-20 x .50 Hex Washer Head Thread
28	06543500	4	Nut, Locking Top Flange .25-20
29	06445000	2	Washer-Flat-Steel .515 x 1.625 x .250
30	06441800	2	Washer-Flat-Steel .518 x 2.0 x .105
31	06545400	6	Nut, Locking-Nylon-Flange .31-18
32	07500103	2	Edging, Clutch Paddle - 2.00"
33	03833800	2	Grip, Adhesive (1" x 16" BLK)

SEAT AND SEAT SUPPORT

Model 915131, 141, 143, 151, 155

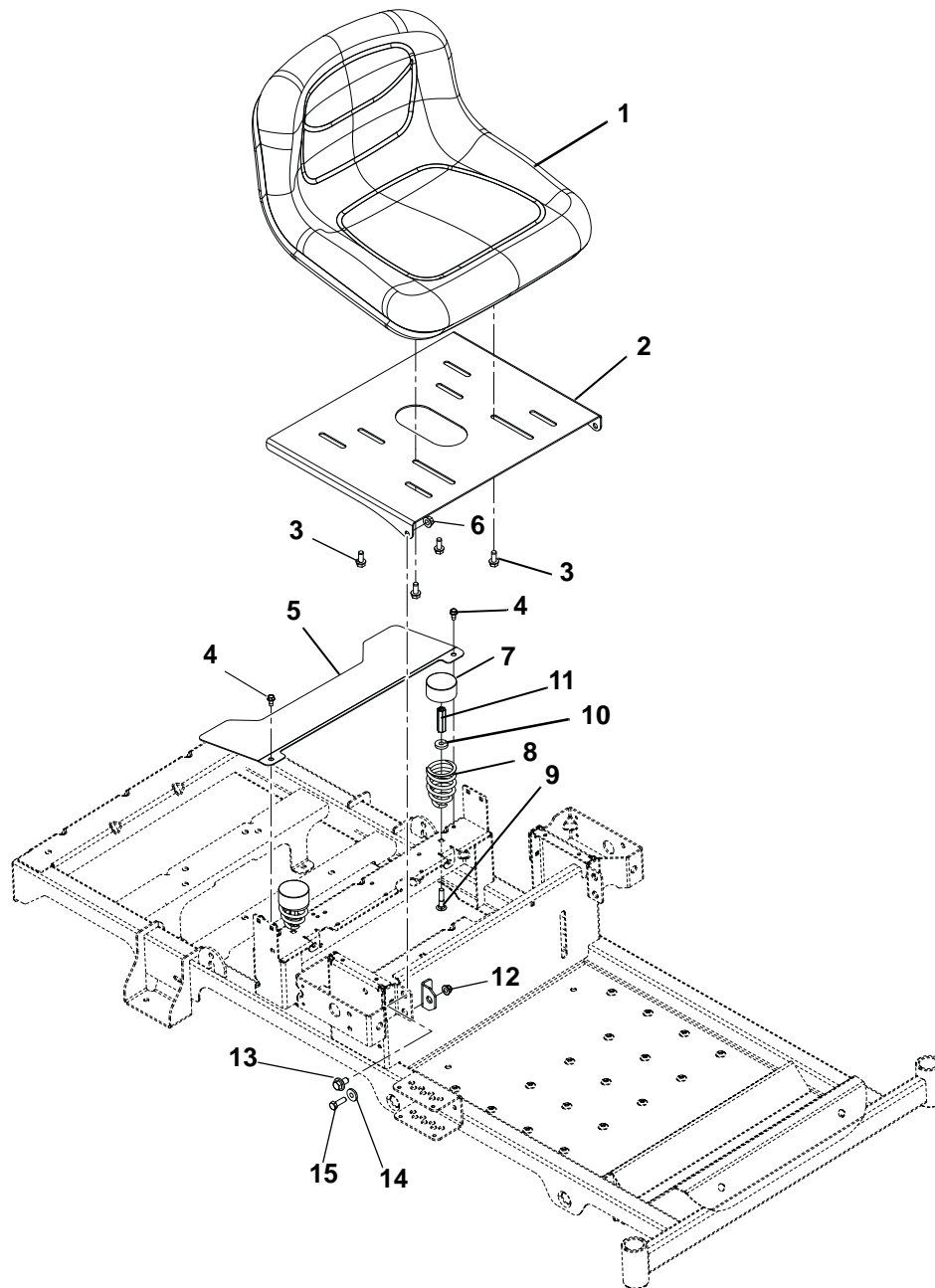

PE1212

SEAT AND SEAT SUPPORT

Model 915131, 141, 143, 151, 155

Item	Part No.	Qty.	Description
1	03795800	1	Seat, 13 in Grey (131, 141, 151, 155)
	03872800	1	Seat, Milsco XB150 GRAY (143)
2	03782051	1	Seat Plate
3	05900033	4	Bolt, Hex 5/16-18 x 3/4
4	07412000	2	Screw, Tapping .25-20 x .50 Hex Washer Head Thread
5	03753351	1	Guard, Fan
6	06542000	2	Nut, .38-16 Locking Top Flange
7	00337700	2	Hub Cap
8	08300021	2	Spring, Seat
9	06212100	2	Bolt, Round Head Square Neck .31-18 x 1.50 Grade 5
10	06439100	2	Washer-Flat-Steel .328 x .87 x .179
11	06500015	2	Nut, Coupling 5/16-18 x 1 .75
12	06545400	2	Nut, 5/16-18 Flange Nyloc
13	07056700	2	Bolt, Shoulder .375-16 x .135
14	01305900	2	Bushing, Flange .325 x .499 x .26 x .88
15	05946900	2	Bolt, Hex .31-18 x 1.00 Grade 5

TRANSAXLE, DUMP VALVES AND REAR WHEELS

Model 915131, 151

Note: Transaxles with Integrated Hub use items 1, 2, 10 and 11.

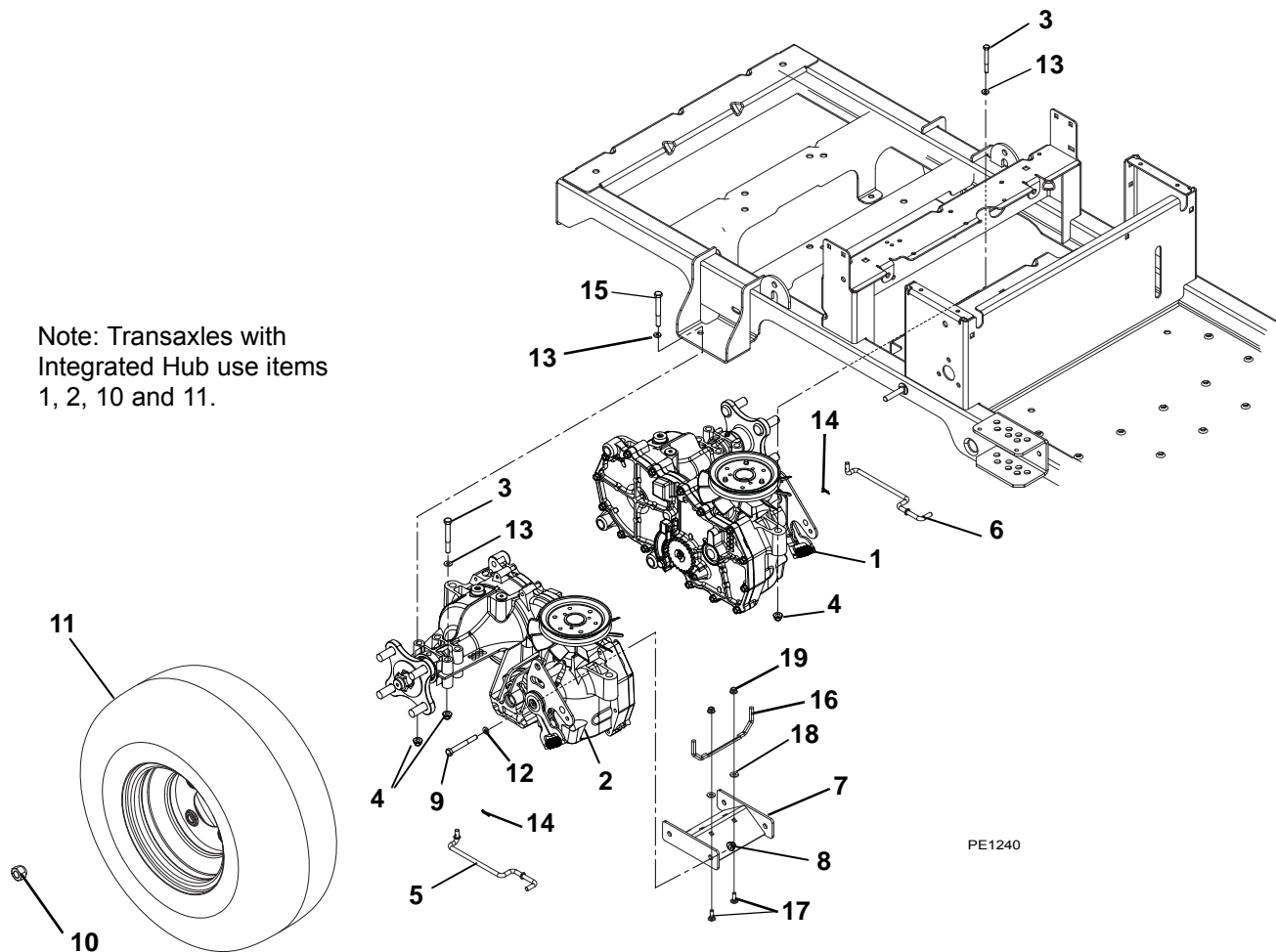

Models with D-Shaft transaxle.

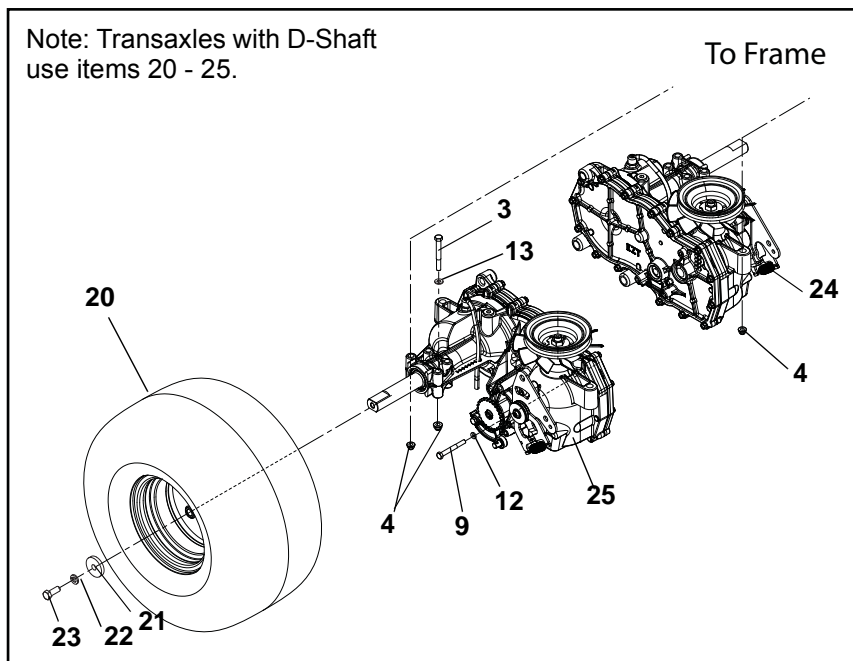

TRANSAXLE, DUMP VALVES AND REAR WHEELS

Model 915131, 151

Item	Part No.	Qty.	Description
1	03762200	1	Transaxle, EZT Short Left Hand
2	03762300	1	Transaxle, EZT Short Right Hand
3	05963700	4	Bolt, Hex .31-18 x 2.25 Grade 5
4	06545400	8	Nut 5/16-18 Flange Nyloc
5	03762700	1	Dump Valve, Right Hand
6	03762800	1	Dump Valve, Left Hand
7	03879551	1	Weldment, Transaxle Brace
8	06545500	4	Nut, Nyloc Flange .38-16
9	05958400	4	Bolt-Hex .38-16 x 2.50 Grade 5
10	06517600	8	Nut, Wheel .50-20 13/16
11	07100738	2	Tire/Wheel Assembly, 18 x 6.5-8 Offset
12	06444000	4	Washer, Flat Steel .406 x 1.00 x .188
13	06435700	8	Washer-Flat-Steel .38 x .875 x .083
14	06701900	2	Pin-Hair-Internal .06 x .18 x .77
15	05960600	4	Bolt, Hex .31-18 x 2.75
16	03879651	1	Belt Finger, Drive Sheave
17	06219900	2	Bolt, Round Head Square Neck .25-20 x .75 Grade 5
18	06437300	2	Washer, Flat-Steel .281 x .62 x .065
19	06500012	2	Nut, Locking Nylon Flange 1/4-20

Note: The following parts are only used with models equipped with the D-Shaft transaxle.

20	07100809	2	Tire, Assembly 18 x 6.5-8 2 Pulley D-Shaft
21	06400006	2	Washer, Flat Steel .406 x 1.50 x .245
22	06308800	2	Washer, Locking .38 x .094 Regular
23	05948700	2	Bolt, Hex .38-16 x 1.00 Grade 5
24	03872300	1	Transaxle, Left Hand EZT D-Shaft
25	03872400	1	Transaxle, Right Hand EZT D-Shaft

TRANSAXLE, DUMP VALVES AND REAR WHEELS

Model 915141, 143, 155

Note: Transaxles with D-Shaft use items 1, 2, 8, 10, 11, 13, 17 and 18.

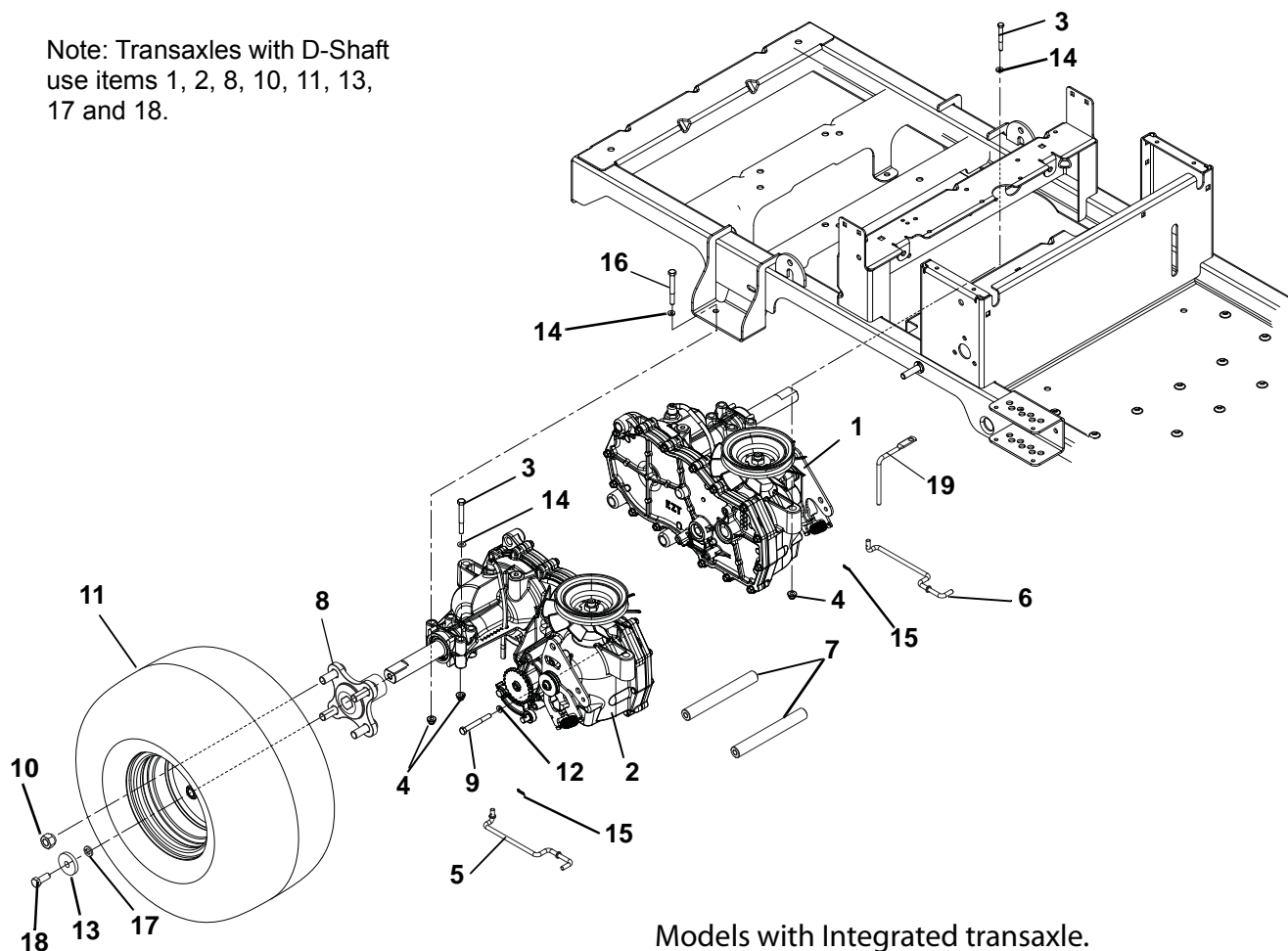

Models with Integrated transaxle.

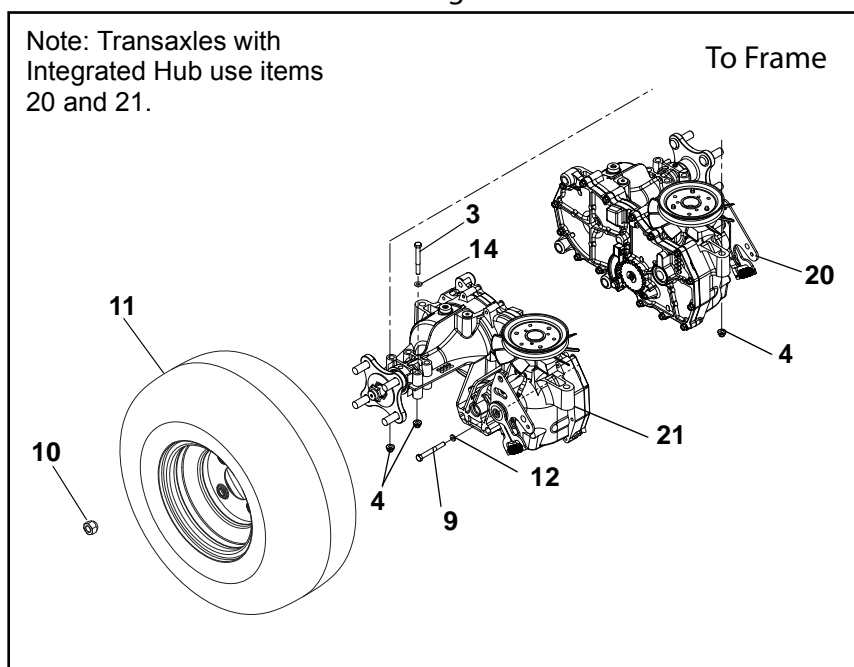

TRANSAXLE, DUMP VALVES AND REAR WHEELS

Model 915141, 143, 155

Item	Part No.	Qty.	Description
1	03872300	1	Transaxle, Left Hand EZT D-Shaft
2	03872400	1	Transaxle, Right Hand EZT D-Shaft
3	05963700	4	Bolt, Hex .31-18 x 2.25 Grade 5
4	06545400	8	Nut 5/16-18 Flange Nyloc
5	03762700	1	Dump Valve, Right Hand
6	03762800	1	Dump Valve, Left Hand
7	03762000	2	Shaft, Cross Brace
8	03958000	2	Assembly, Wheel Hub
9	05958400	4	Bolt-Hex .38-16 x 2.50 Grade 5
10	06517600	8	Nut, Wheel .50-20 13/16
11	07100123	2	Tire/Wheel Assembly, 18 x 8.5-8 Center (141, 155)
	07100233	2	Tire/Wheel Assembly, 18 x 9.50-8 Offset (143)
12	06444000	4	Washer, Flat Steel .406 x 1.00 x .188
13	06400006	2	Washer, Flat Steel .406 x 1.50 x .245
14	06435700	8	Washer, Flat-Steel .38 x .875 x .083
15	06701900	2	Pin-Hair-Internal .06 x .18 x .77
16	05960600	4	Bolt, Hex .31-18 x 2.75
17	06308800	2	Washer, Locking .38 x .094 Regular
18	05948700	2	Bolt, Hex .38-16 x 1.00 Grade 5
19	03956151	1	Belt Finger (141)
20	03762200	1	Transaxle, EZT Short Left Hand
21	03762300	1	Transaxle, EZT Short Right Hand

PARKING BRAKE

Model 915131, 141, 143, 151, 155

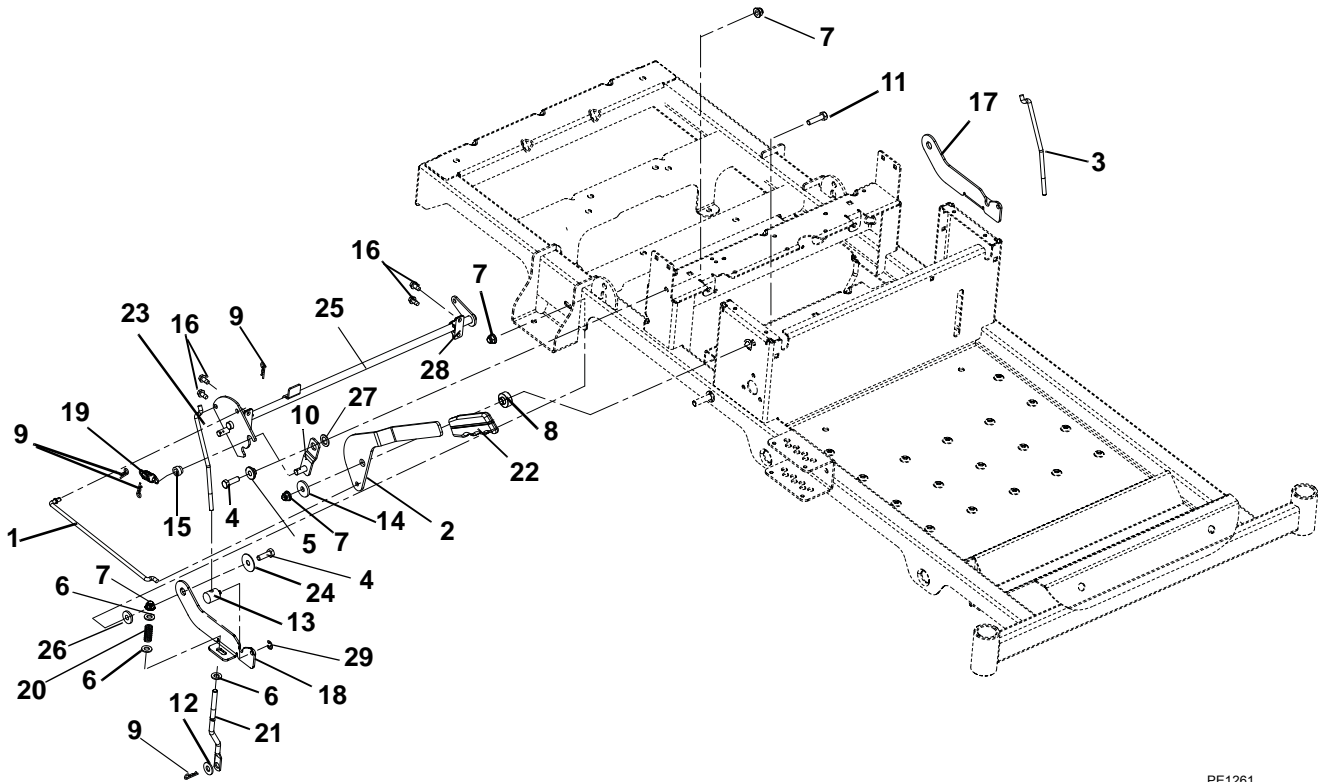

PE1261

Item	Part No.	Qty.	Description
1	03759400	1	Link, Brake Handle
2	03759100	1	Handle, Parking Brake
3	03823300	1	Link, Neutral LH
4	05946900	3	Bolt, Hex .31-18 x 1.00 Grade 5
5	05514800	1	Bushing, Flange .312 x .500 x .344 x .880
6	06437200	6	Washer, Flat-Steel .344 x .688 x .065
7	06545400	6	Nut, Flange Nyloc 5/16-18
8	03769400	1	Spacer, Brake Handle
9	06713500	5	Pin, Hair Internal .08 x .18 x 1.18
10	03759200	1	Weldment, Detent Arm
11	05947500	1	Bolt, Hex .31-18 x 1.25 Grade 5
12	06435700	2	Washer, Flat Steel .38 x .875 x .083
13	03764800	2	Trunnion, 1/4-20
14	06446300	1	Washer, Flat Steel .344 x 1.125 x .135
15	03764900	1	Roller
16	07400034	4	Screw, Tapping .25-20 x .50 Hex Washer Head
17	03759000	1	Latch, LH Neutral
18	03758900	1	Latch, RH Neutral
19	08326700	1	Spring, Tension .072 x .565 x 1.87
20	08300028	2	Spring, Compression
21	03759600	2	Link, Brake Cog
22	03826900	1	Grip, Parking Brake
23	03759500	1	Link, Neutral RH
24	06446900	2	Washer, Flat Steel .347 x 1.254 x .048
25	03761100	1	Weldment, Brake Shaft
26	01305900	2	Bushing, Flange .325 x .499 x .26 x .88
27	06441100	1	Washer, Flat-Steel .52 x .827x .062
28	03757501	2	Bushing, .50 Clamp Block Molded
29	05700125	2	Ring, Retaining-External .250 x .025

NOTES

STEERING CONTROLS

Model 915131, 141, 143, 151, 155

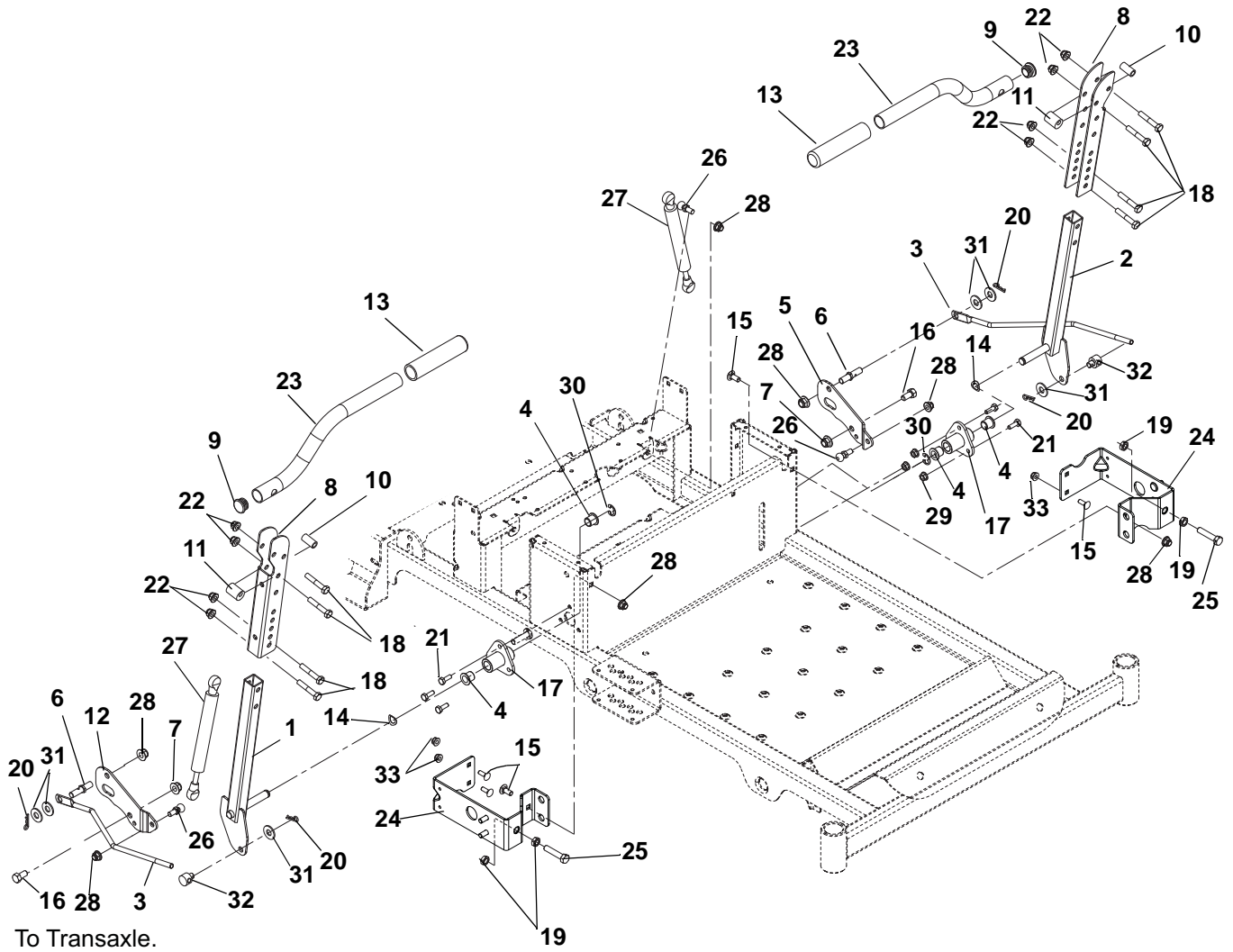

STEERING CONTROLS

Model 915131, 141, 143, 151, 155

Item	Part No.	Qty.	Description
1	03735051	1	Weldment, RH Control Arm
2	03734951	1	Weldment, LH Control Arm
3	03765600	2	Link, Steering
4	05500908	4	Bushing, Flanged .500 x .625
5	03766051	1	Plate, Damper LH
6	03767000	2	Pin, Trans
7	06545500	4	Nut, .38-16 Nyloc Flange
8	00481751	2	Channel, Upper Handlebar
9	07533300	2	Caplug, Handlebar
10	00364900	2	Bushing
11	00372300	2	Eccentric
12	03759351	1	Plate, Damper RH
13	07518700	2	Grip, Handlebar
14	06436600	2	Washer, Flat-Steel .505 x .880 x .072
15	06220800	6	Bolt, Round Head Square Neck .31-18 x .75
16	05959400	2	Bolt, Hex .38-16 x .75 Grade 5
17	03732900	2	Bushing, Flanged
18	05901328	8	Bolt, Hex .31-18 x 1.75 Grade 5
19	06535900	4	Nut, Hex Jam .375-16
20	06713500	4	Pin, Hair Internal .08 x .18 x 1.18
21	05946800	6	Bolt, Hex .25-20 x .75 Grade 5 or
	07400034	6	Screw, Tapping .25-20 x .50 Hex Washer Head
22	06500634	8	Nut, .31-18 Nyloc Flange
23	03735151	2	Handle, Steering
24	03956251	2	Bracket, Speed Adjustment/Seat Pivot (915131, 151 SN 010501 and up, 141, 143)
	03778151	2	Bracket, Speed Adjustment/Seat Pivot (915131, 151 SN 010000 - 010500)
25	05974000	2	Bolt, Hex .375-16 x 1.750 Full Thread
26	03652200	4	Stud, Ball
27	03943800	2	Damper
28	06545400	6	Nut, Flange .31-18
29	06543500	6	Nut, Locking-Top-Flange .25-20 (not used with 07400034, item 21)
30	05710200	2	Ring, Retaining External .500 x .042
31	06435900	4	Washer, Flat Steel .438 x 1.00 x .083
32	01596400	2	Trunnion, Brake .31-18
33	06500012	4	Nut, .25-20 Nyloc Flange

ENGINE, EXHAUST, BELTS AND IDLERS

Model 915131, 141, 143, 151, 155, 151, 155

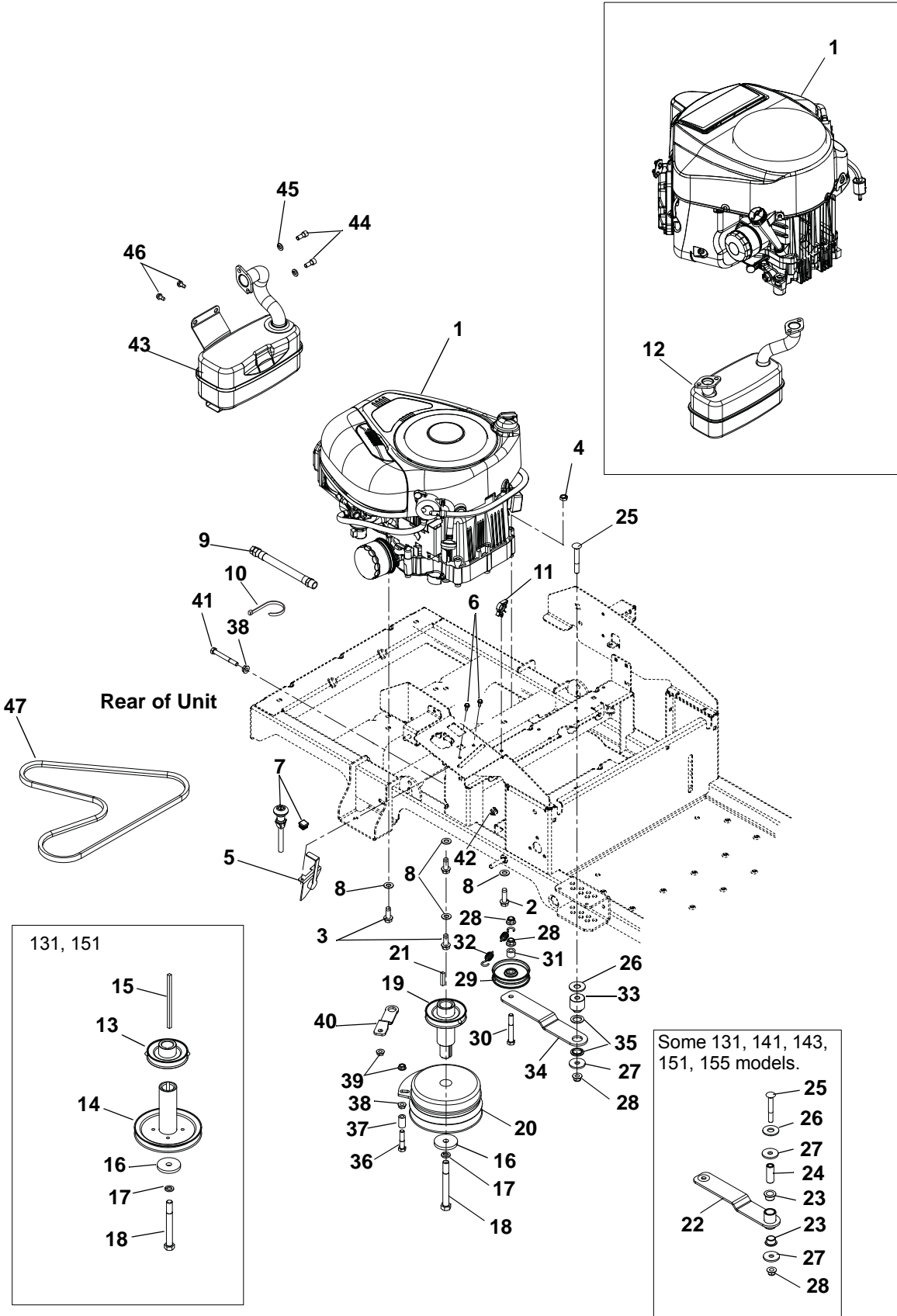

ENGINE, EXHAUST, BELTS AND IDLERS

Model 915131, 141, 143, 151, 155, 151, 155

Item	Part No.	Qty.	Description
1	08200433	1	Engine, 13.5 HP Briggs and Stratton IC (131, 151)
	08200317	1	Engine, 16.5 HP Briggs and Stratton (141)
	08200520	1	Engine, FR651-22 Kawasaki Twin (143)
	08200538	1	Engine, 13.5HP Briggs and Stratton PP W/Muffler (151)
	08200536	1	Engine, 16.5HP Briggs and Stratton PP without Muffle (155)
2	07414700	1	Screw, Tapping .38-16 x 1.25 Hex Washer Head (131, 141, 151, 155)
	05900125	4	Bolt, Hex .38-16 x 1.25 FTHG5 (143)
3	07414100	3	Screw, Tapping .38-16 x 1.00 Hex Washer Head (131, 141, 151, 155)
4	06537200	1	Nut, Locking Jam .375-16 (131, 141, 151, 155)
5	00619600	1	Throttle/Choke Cable (131, 141, 151, 155)
	06900416	1	Throttle Cable (143)
6	07415800	2	Screw, Tapping 10-24 x .50 Hex Washer Head
7	07500123	1	Plug, 5/8" Square Black (14-20GA) (131, 141, 151, 155)
	06900408	1	Cable, Choke (SNAP IN) (143)
8	06436200	4	Washer, Flat-Steel .406 x .812 x .065 (143)
9	03844200	1	Oil Drain Hose
10	04003800	1	Tie Wrap
11	00390100	1	Wire Clip (FOR .25" HOLE)
12	03946900	1	Muffler, Twin (143)
13	03770800	1	Weldment, Sheave, Ground Drive
14	03766751	1	Sheave, PTO Drive
15	06600212	1	Key, Straight .25 x .25 x 5.50
16	06443600	1	Washer, Flat-Steel .469 x 2.00 x .25
17	06309300	1	Washer, Locking .44 x .109 Regular
18	05966700	1	Bolt, Hex .44-20 x 4.50 Grade 8
19	03992000	1	Weldment, PTO Extension w/Sheave (141, 143, 155)
20	03972700	1	Clutch, 105 FT*LB MONO Pole (141, 143, 155)
21	06603400	1	Key, Square .25 x 1.25 x .25 SAE 8630 OR SAE 1035 (141, 143, 155)
22	03754300	1	Weldment, Idler Arm (131, 143, 151)
23	05500907	2	Bushing, Flange, .625 x .750 x .500 x 1.00 (131, 143, 151)
24	03763400	1	Spacer, .375ID x .625OD x 1.66
25	06225400	1	Bolt, Round Head Square Neck .38-16 x 2.75 Grade 5
26	06442000	1	Washer, Flat-Steel .563 x 1.38 x .109
27	06442400	2	Washer, Flat-Steel .406 x 1.375 x .135
28	06545500	3	Nut, Locking-Nylon-Flange .38-16
29	07300221	1	Pulley, Engine Clutch
30	05961400	1	Bolt, Hex .38-16 x 2.75 Grade 5
31	08553700	1	Bushing, Sleeve .391 x .688 x .52
32	08300512	1	Spring, Extension
33	03961100	1	Spacer, Ground Drive Idler
34	03961000	1	Idler Arm, Ground Drive
35	03960700	1	Bushing, Idler Arm
36	05901418	1	Screw, Cap .31-18 x 1.75 (141, 143, 155)
37	03980200	1	Spacer, Rubber 5/16 ID x 1.0 (141, 143, 155)
38	06530400	2	Nut, Spin Lock-Flange .312-18
39	06543100	2	Nut, Locking-Top-Flange .31-18 (141, 143, 155)
40	03956751	1	Bracket, Clutch Stop (141, 143, 155)
41	05960600	1	Bolt, Hex .31-18 x 2.75 Grade 5
42	06545400	1	Nut, Locking-Nylon-Flange .31-18
43	04058800	1	Muffler, Briggs and Stratton 208 BBZ (141, 155)
44	05933100	2	Screw, Cap .31-18 x .75 S/HD (141, 155)
45	06308600	2	Washer, Locking .31 x .078 Regular (141, 155)
46	07400034	2	Screw, Tapping .25-20 x .50 Hex Washer Head (141, 155)
47	07200010	1	V-Belt, HA-RAW Edge Laminated

FUEL TANK

Model 915131, 141, 143, 151, 155, 151, 155

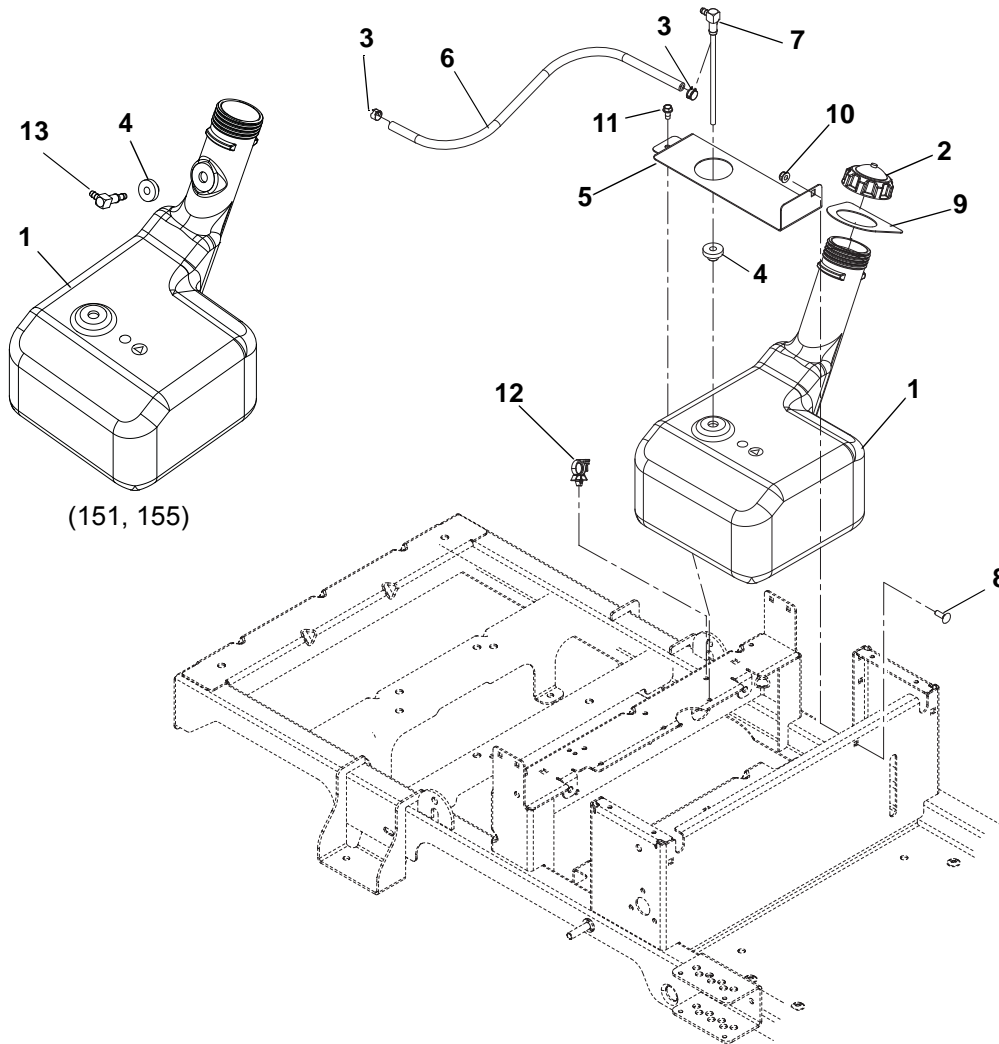

(151, 155)

Item	Part No.	Qty.	Description
1	03761700	1	Tank, Fuel (131, 141, 143)
	04082200	1	Tank, Fuel 2.5G w/Vent Port (151, 155)
2	01538400	1	Fuel Cap (131, 141, 143)
	04082300	1	Fuel Cap, 225 Carb w/12" THTR
3	03278800	2	Clamp, Fuel Line
4	07511400	1	Bushing (131, 141, 143)
	07511400	2	Bushing (151, 155)
5	03771451	1	Bracket, Tank Strap
6	03278100	10in.	Hose, .25 Low Perm Gas
7	03875200	1	Assembly, Fuel Pickup
8	06219900	1	Bolt, Round Head Square Neck .25-20 x .75 Grade 5
9	03795700	1	Seal, Tank Neck
10	06500012	1	Nut, .25-20 Nyloc Flange
11	07400034	1	Screw, Tapping .25-20 x .50 Hex Washer Head
12	00390100	1	Wire Clip
13	04182900	1	Fitting, 90 Degree .25" Fuel (151, 155)

CONTINUITY DIAGRAM

Model 915131, 141, 143, 151, 155, 151, 155

The diagrams below show the various states of connection for electrical components.
The solid lines on switches show continuity.
NOTE: All switches are viewed from the rear.

Key Switch (03290500)

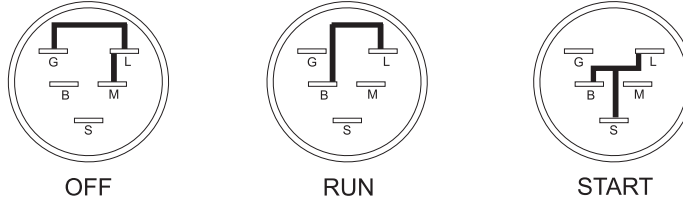

PTO Switch (01545600)

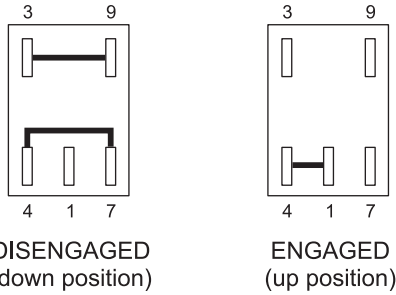

Relay (03042800)

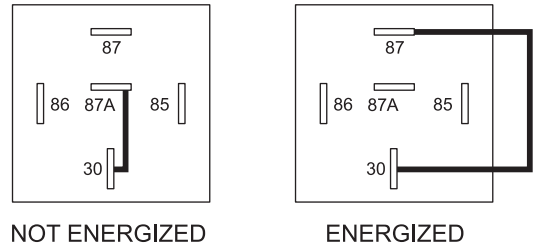

Seat Switch (03654200)

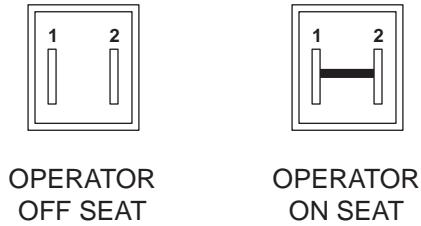

Park Brake Switch (03606600)

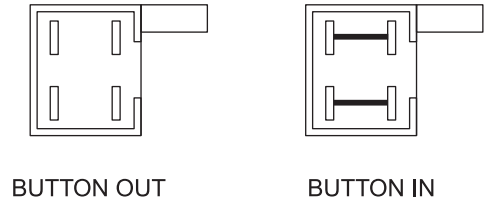

Solenoid (00696900)

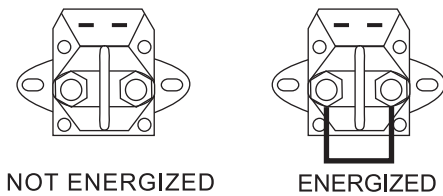

PE0771

ELECTRICAL SYSTEM

Model 915131, 141, 143, 151, 155, 151, 155

Item	Part No.	Qty.	Description
1	03927000	1	Key
2	03042800	1	Relay
3	09351100	1	Fuse, 30 AMP
4	03290500	1	Key Switch w/Key
5	00696900	1	Solenoid
6		1	Battery, Sealed Maintenance free U1-250 (Purchase replacement locally)
7	05946800	2	Bolt, Hex .25-20 x .75 Grade 5
8	06437300	8	Washer, Flat Steel .281 x .62 x .065 (131, 151)
	06437300	2	Washer, Flat Steel .281 x .62 x .065 (141, 143, 155)
9	06509200	2	Nut, KEPS .250-20
10	07533200	3	Boot, Eyelet Terminal
11	03777100	1	Cable, POS
12	03777000	1	Ground Cable
13	01545600	1	Switch, Clutch With Retainer
14	03773900	1	Harness, Wiring Zoom/ZT
15	03606600	1	Switch, Double Pole N.O. / N.O.
16	03654200	1	Switch, Snap Mounting (N.O.)
17	07505700	1	Insulator
18	06310500	4	Washer, Locking .31
19	06536700	2	Nut, Jam .31-24
20	06500012	4	Nut, .25-20 Nyloc Flange (131, 151)
	06500012	1	Nut, .25-20 Nyloc Flange (141, 143, 155)
21	03773800	1	Actuator-NORAM PAC 2" (131, 151)
22	05961600	3	Bolt, Hex .25-20 x 2.50 Grade 5 (131, 151)
23	07506500	1	Grommet .125 x 1.000 ID
24	07411600	2	Screw, Tapping .250-20 x .37 Hex Washer Head
25	06543500	1	Nut, Locking-Top-Flange .25-20
26	07400038	2	Screw, 12-14 x .75 HX
27	03781900	1	Hold Down, Battery
28	03972600	1	Harness, Clutch (141, 143, 155)
29	08300504	1	Spring, Compression (131, 151)
30	03896500	1	Retainer, Compression Spring (131, 151)
31	07411900	1	Screw, Tapping 12-24 x .50 Hex Washer Head
32	05973300	1	Bolt, Hex M8-1.25 x 20(143)
33	06308600	1	Washer, Locking .31 x .078 Regular(143)
34	06537200	1	Nut, Locking-Center-Jam .375-16(131, 141, 151, 155)

WIRING DIAGRAM

Model 915131, 151

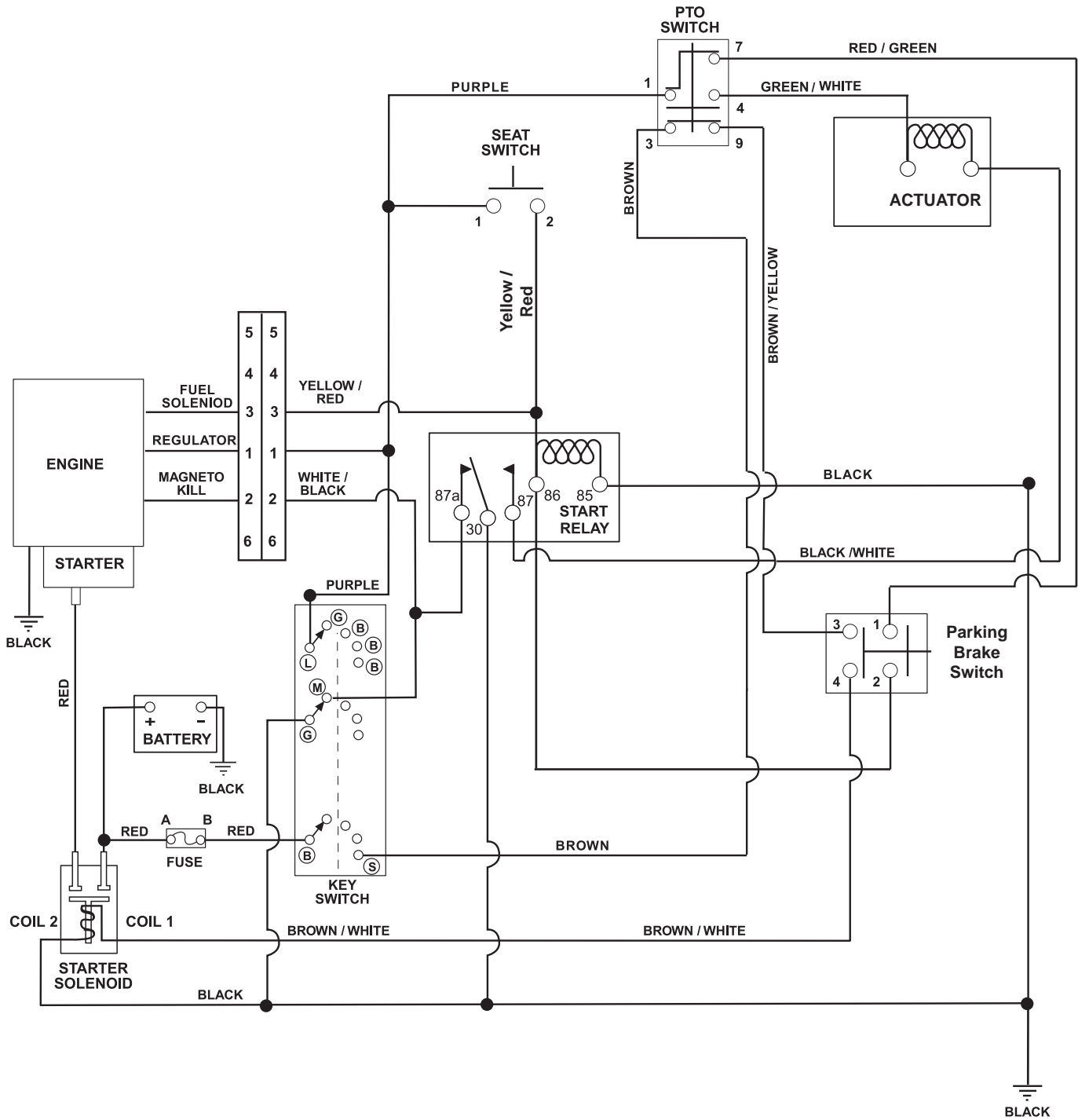

PE1290

WIRING DIAGRAM

Model 915141, 143, 155

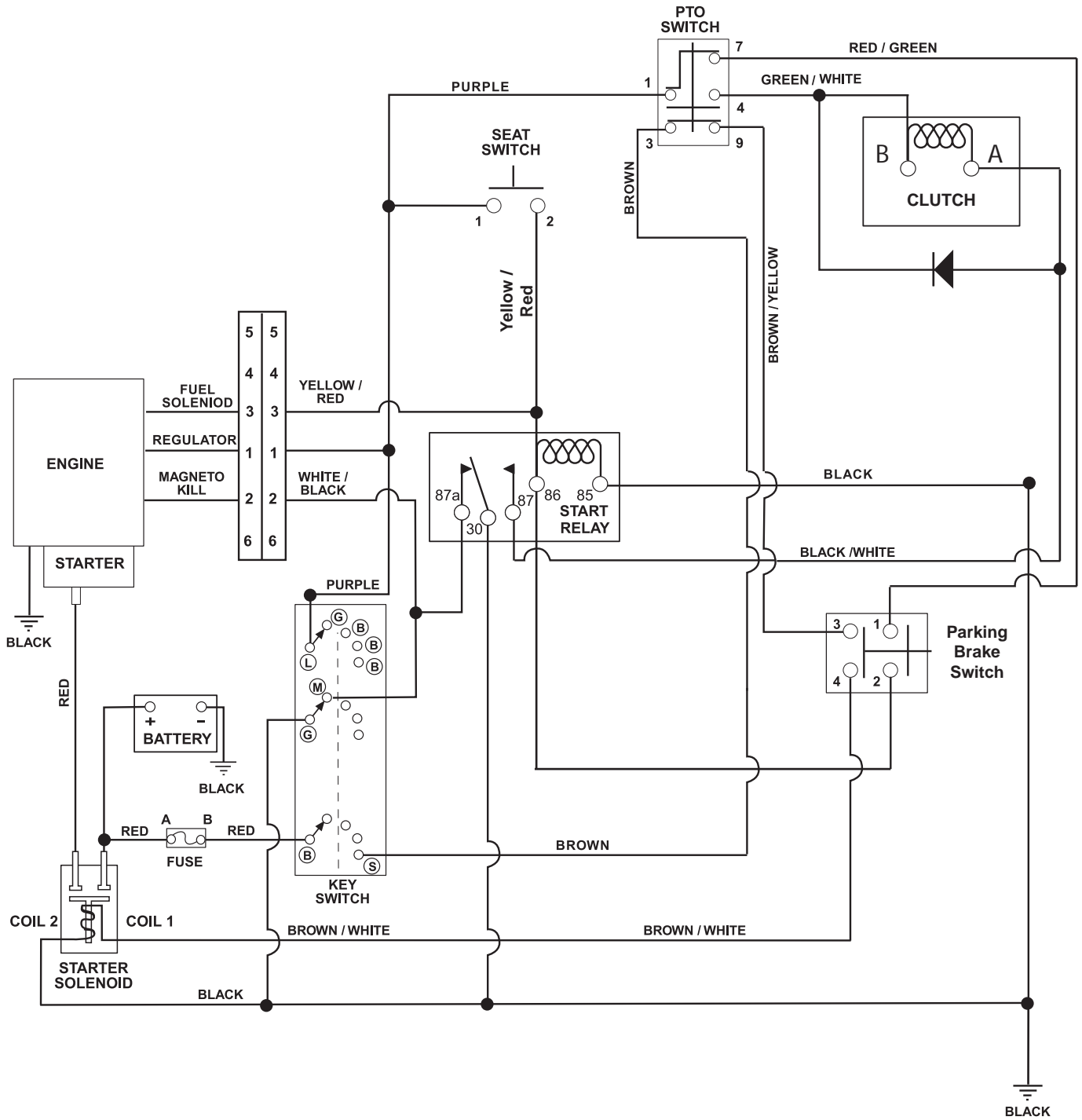

MOWER DECK LIFT

Model 915131, 141, 143, 151, 155, 151, 155

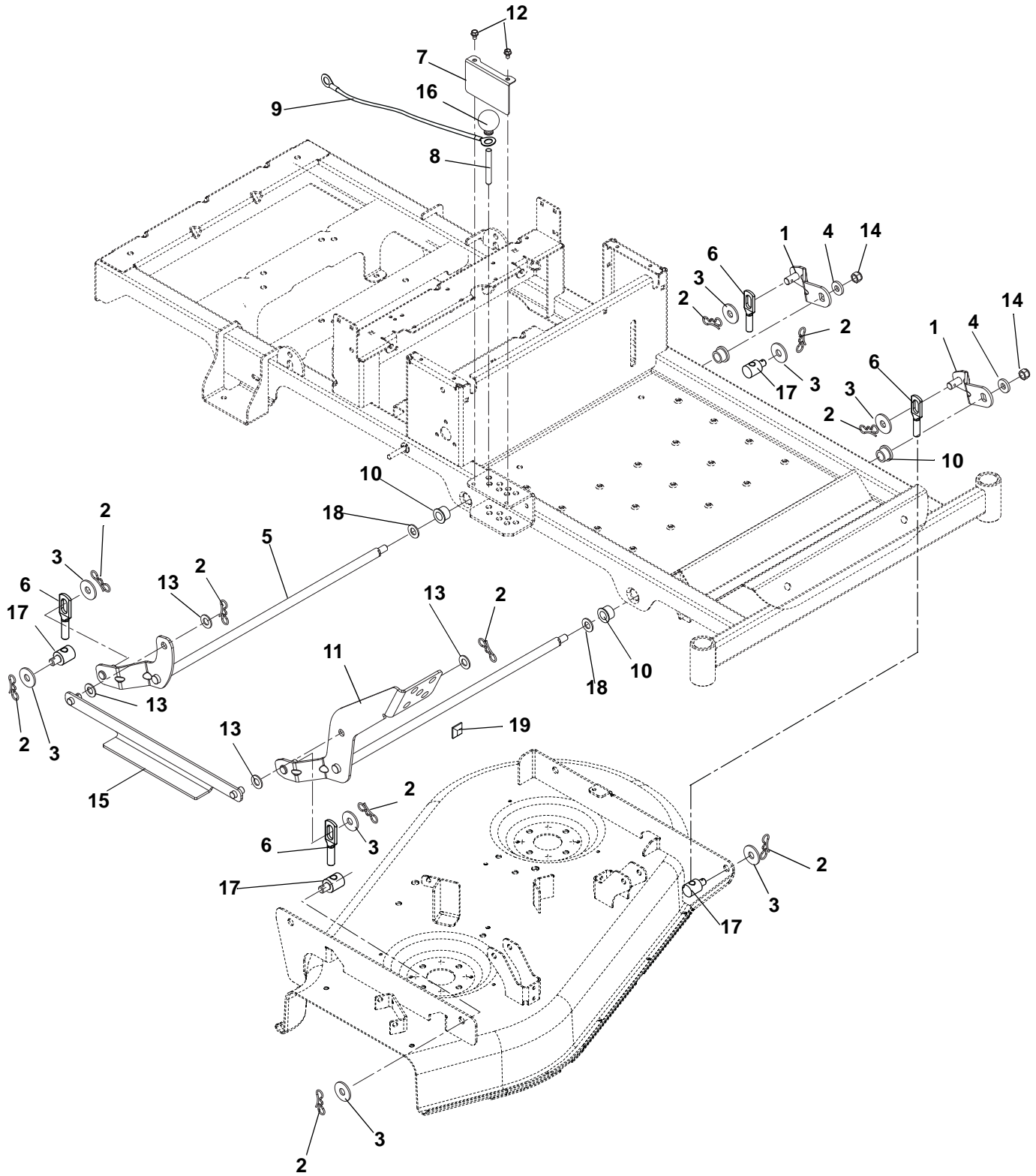

MOWER DECK LIFT

Model 915131, 141, 143, 151, 155, 151, 155

Item	Part No.	Qty.	Description
1	03745400	2	Weldment, Lift Arm
2	06700201	10	Pin, Bow Tie Locking Cotter .091 x 1.875
3	06436400	8	Washer, Flat-STL.511 x 1.441 x .125
4	06400903	2	Washer, Flat-Steel .50 x 1.25 x .160
5	03746100	1	Weldment, Rear Deck Lift Shaft
6	00160000	4	Assembly, Deck Link
7	03766151	1	Guard, Deck Lift
8	03755200	1	Pin, Deck
9	03820800	1	Lanyard, Galvanized 12"
10	05519100	4	Bushing, Flange .627 x .879 x .469 x 1.120
11	03744800	1	Weldment, Deck Lift Pedal
12	07411600	2	Screw, Tap .25-20 x .37
13	06443300	4	Washer, Flat-Nylon .52 x 1.00 x .08
14	06500633	2	Nut, Nyloc 7/16-20
15	03745300	1	Weldment, Lift Link
16	07533500	1	Knob, Ball - Black 1.47" .375-16
17	01590400	4	Trunnion, .50
18	06442800	2	Washer, Flat Steel .656 x 1.31 x .095
19	07525100	1	Bumper, Rubber

MOWER DECK, BELT, AND IDLERS

Model 915131, 151

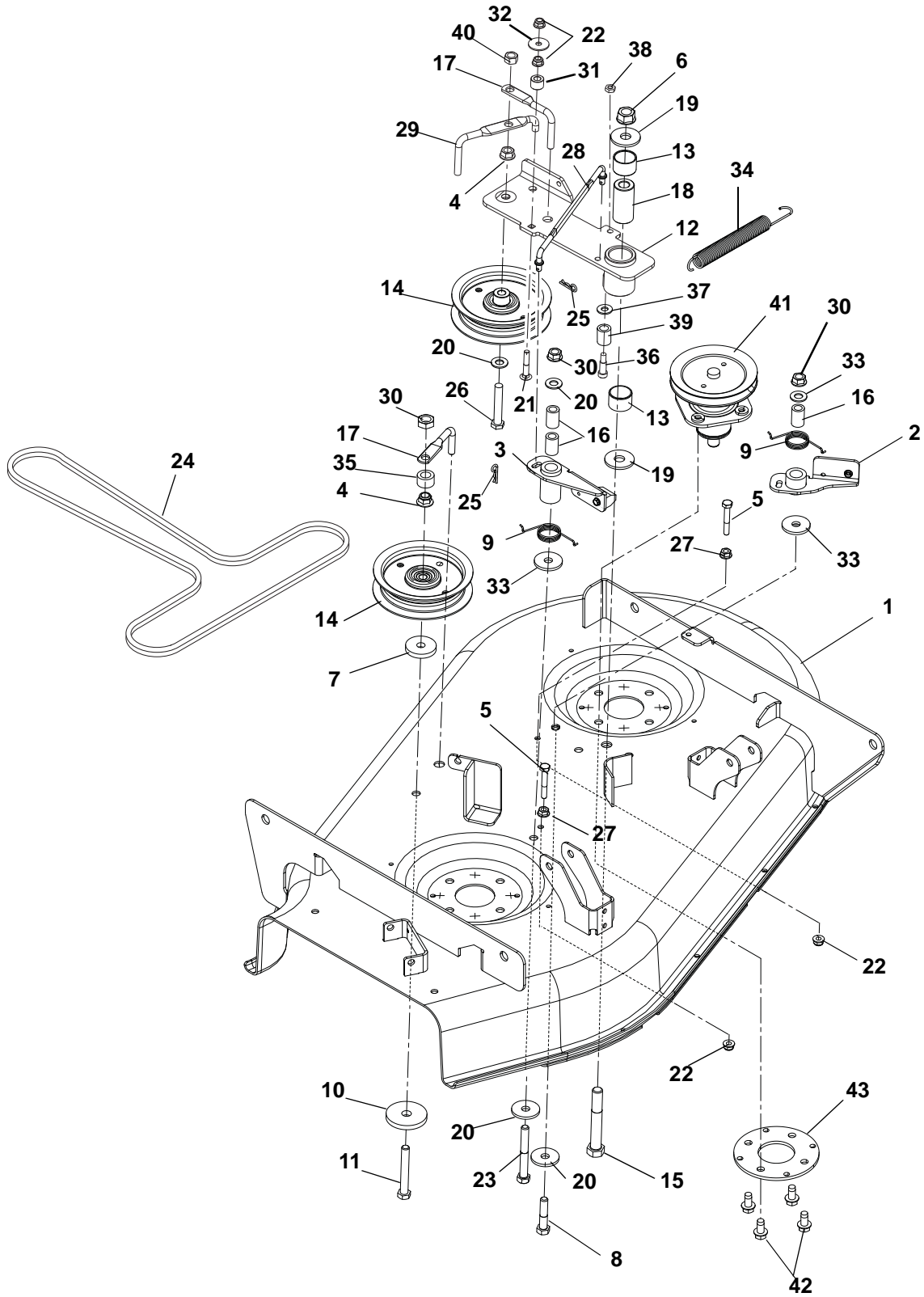

PE0870

MOWER DECK, BELT, AND IDLERS

Model 915131, 151

Item	Part No.	Qty.	Description
1	03886459	1	Weldment, 34in Deck
2	51519800	1	Assembly, Brake Arm RH
3	51519900	1	Assembly, Brake Arm LH
4	06542000	2	Nut, Locking Top Flange .38-16
5	05964700	2	Bolt, Hex .25-20 x 1.75 Grade 5
6	06543600	1	Nut, Locking Top Flange .50-13
7	06400006	1	Washer, Flat Steel .406 x 1.50 x .245
8	05958500	1	Bolt, Hex .38-16 x 1.75 Grade 5
9	08300502	2	Spring, Torsion
10	06443600	1	Washer, Flat Steel .469 x 2.00 x .25
11	05961400	1	Bolt, Hex .38-16 x 2.75 Grade 5
12	03875600	1	Idler Arm
13	05435800	2	Bearing, 1.00 x 1.12 x .75
14	07300039	2	Assembly, Idler 4"
15	05965800	1	Bolt, Hex Head .50-13 x 3.50 Grade 5
16	08833400	3	Bushing, Sleeve .391 x .622 x .950
17	03828859	2	Finger, Belt
18	01581700	1	Spacer, Powdered Metal
19	06436400	2	Washer, Flat Steel .511 x 1.44 x 125
20	06436200	3	Washer, Flat Steel .406 x .812 x .065
21	06222300	1	Bolt, Round Head Square Neck .25-20 x 1.50 Grade 5
22	06500012	4	Nut, .25-20 Nyloc Flange
23	05961400	1	Bolt, Hex .38-16 x 2.75 Grade 5
24	07200116	1	Belt, HA 98.75 Wrapped
25	06713500	2	Pin, Hair .08 x .18 x 1.18
26	05962900	1	Bolt, Hex .38-16 x 2.25 Grade 5
27	06530100	2	Nut, Locking Flange .250-20
28	03771700	1	Link, Brake
29	03856859	1	Wireform, Belt Finger
30	06537200	3	Nut, Locking Jam .375-16
31	03242100	1	Spacer, .325 x .625 x .455
32	06426600	1	Washer, Flat-Steel .281 x 1.000 x .063
33	06442400	2	Washer, Flat-Steel .406 x 1.375 x .135
34	08316400	1	Spring, Tension .062 x .56 x 8.0
35	05522100	1	Bushing, Sleeve .377 x .624 x .370
36	05901340	1	Bolt, SHSB .25-20 x .312 x .625
37	06442300	1	Washer, Flat-Steel .25 x .562 x .049
38	06500635	1	Nut, Locking-Center Jam .25-20
39	03877100	1	Roller, .50 x .328 x .625
40	06529600	1	Nut, Locking-Center .38-16
41	51519500	2	Kit, Deck Spindle Assembly (34/50)
42	07415400	8	Screw, Tapping .38-16 x .75 Hex Washer Head
43	03839059	2	Plate, Reinforced Spindle

MOWER DECK, BELT, AND IDLERS

Model 915141, 143, 155

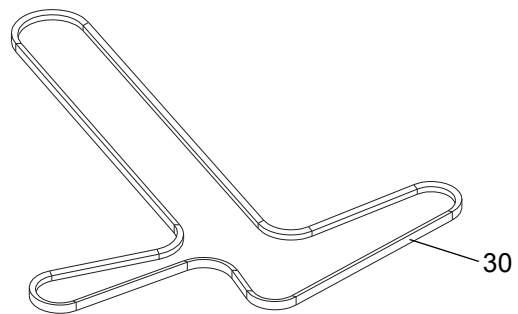
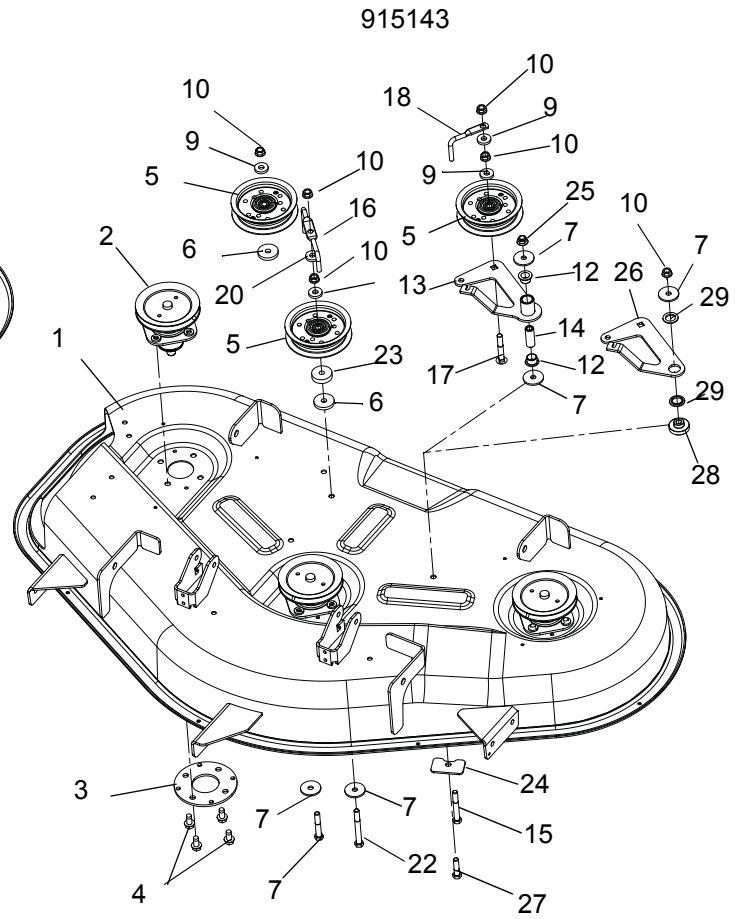
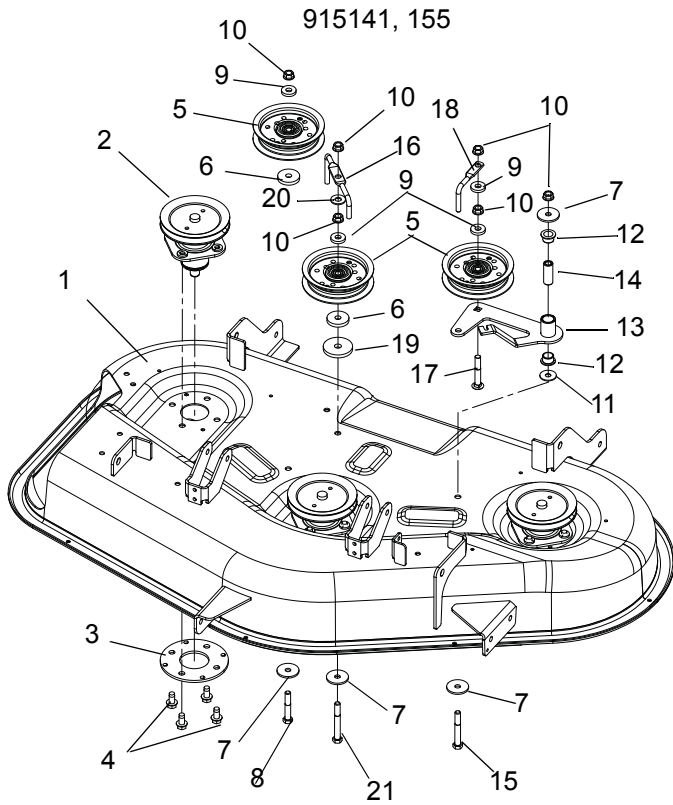

MOWER DECK, BELT, AND IDLERS

Model 915141, 143, 155

Item	Part No.	Qty.	Description
1	03967759	1	Deck, 42" (141, 155)
	03945959	1	Deck, 50" (143)
2	51520900	3	Assembly, Spindle (141, 155)
	51519500	3	Assembly, Spindle (143)
3	03839059	3	Plate, Spindle
4	07415400	12	Screw, Tapping .38-16 x .75 Hex Washer Head
5	07300039	3	Assembly, Idler 4"
6	06400006	2	Washer, Flat Steel .406 x 1.50 x .245
7	06443400	4	Washer, Flat-Steel .380 x 1.50 x .125
8	05962900	1	Bolt, Hex .38-16 x 2.25 Grade 5
9	06444000	4	Washer, Flat-Steel .406 x 1.00 x .188
10	06542000	6	Nut, Locking-Top-Flange .38-16
11	06425500	1	Washer, Flat-Steel .375 x 1.125 x .065
12	05500907	2	Bushing, Flange, .625 x .750 x .500 x 1.00
13	04072900	1	Weldment, Idler Arm
14	03763400	1	Spacer, .375ID x .625OD x 1.66
15	05961400	1	Bolt, Hex .38-16 x 2.75 Grade 5
16	03974159	1	Belt Finger
17	06224400	1	Bolt, Round Head Square Neck .38-16 x 2.50 Grade 5
18	03828859	1	Wireform Belt Finger
19	06443600	1	Washer, Flat-Steel .469 x 2.00 x .25
20	06435900	1	Washer, Flat-Steel .438 x 1.00 x .083 (141, 155)
21	05957800	1	Bolt, Hex .38-16 x 3.00 Grade 5 (141, 155)
22	05961100	1	Bolt, Hex .38-16 x 3.25 Grade 5 (143)
23	01594000	1	Spacer, .39 x 1.50 x .380 (143)
24	04061059	1	Plate, Deck (143)
25	06545500	1	Nut, Locking-Nylon-Flange .38-16 (143)
26	03956000	1	Idler Arm (143)
27	05957900	1	Bolt, Hex .38-16 x 1.50 Grade 5 (143)
28	03960600	1	Spacer, Idler Arm (143)
29	03960700	2	Bushing, Idler Arm (143)
30	07200523	1	V-Belt, 4L Wrapped (141, 155)
	07200524	1	V-Belt, 4L Wrapped (143)

BELT COVERS AND BLADES

Model 915131, 151

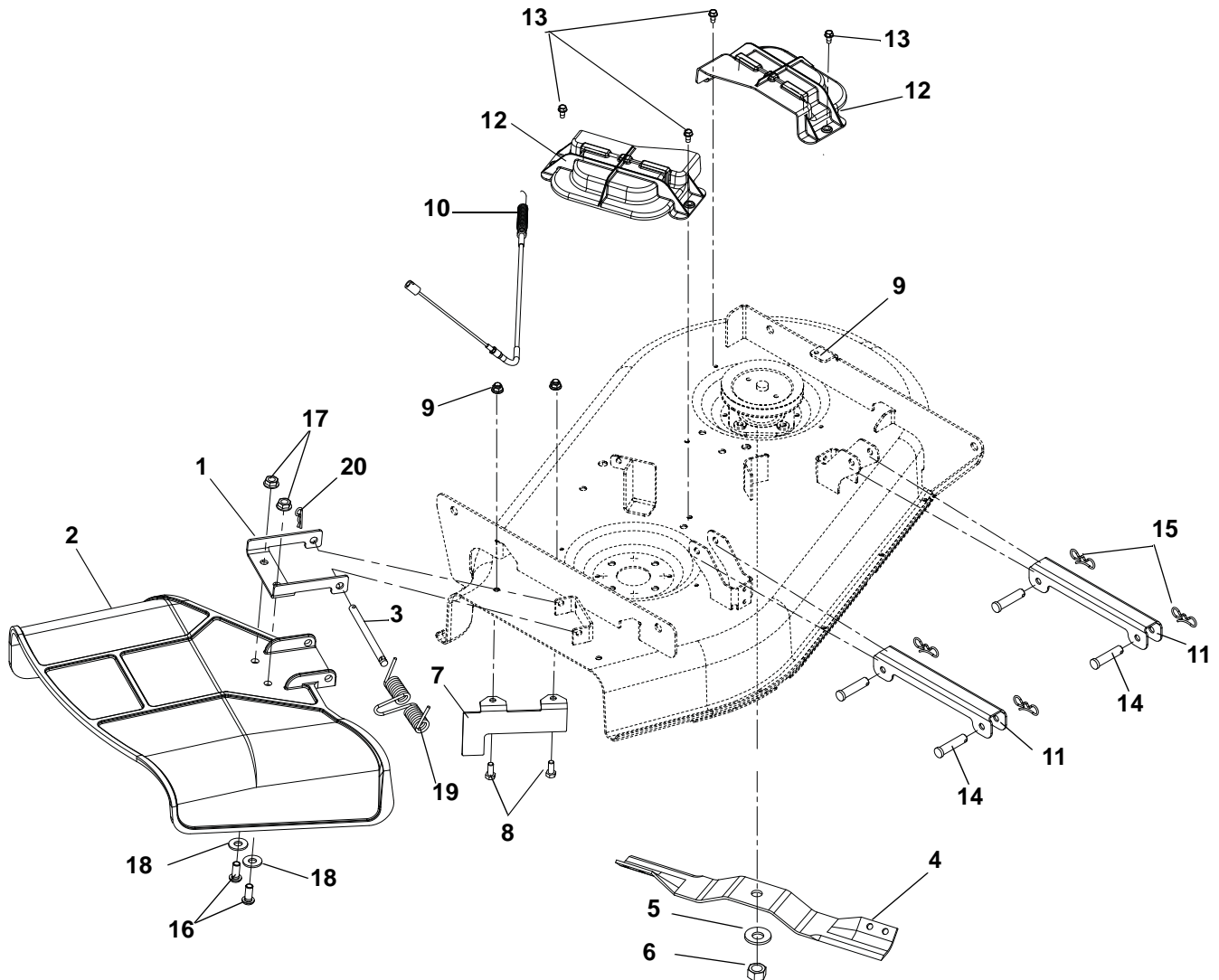

Item	Part No.	Qty.	Description
1	00662659	1	Chute Reinforcement
2	03394300	1	Molded Chute
3	06800002	1	Pin, 5/16 x 3.88"
4	03746500	2	Blade, 17.2" x .156 (SN - 000101 thru 011621)
	03971900	2	Blade, Mower 17.35 (SN - 011622 and up)
5	06445700	2	Washer, Beveled .63 x 1.625 x .14
6	06500630	2	Nut, Hex .62-18
7	03779259	1	Bracket, Baffle Discharge 34"
8	05947000	2	Bolt, Hex .31-18 x .75 Grade 5
9	06545400	2	Nut, .31-18 Nyloc Flange
10	06900338	1	Cable, PTO
11	03764059	2	Bracket, Stabilizer Link
12	03796000	2	Cover, Belt Molded
13	07400034	4	Screw, Tapping .25-20 x .50 Hex Washer Head
14	06800102	4	Pin, Clevis .375 x 2.00
15	06700206	4	Pin, Bow Tie Locking
16	05920900	2	Screw, .31-18 x .75
17	06543100	2	Nut, Locking Top Flange .31-18
18	06435700	2	Washer, Flat-Steel .38 x .875 x .083
19	01258100	1	Spring, Torsion
20	06713500	1	Pin, Hair .08 x .18 x 1.18

BELT COVERS AND BLADES

Model 915141, 143, 151, 155

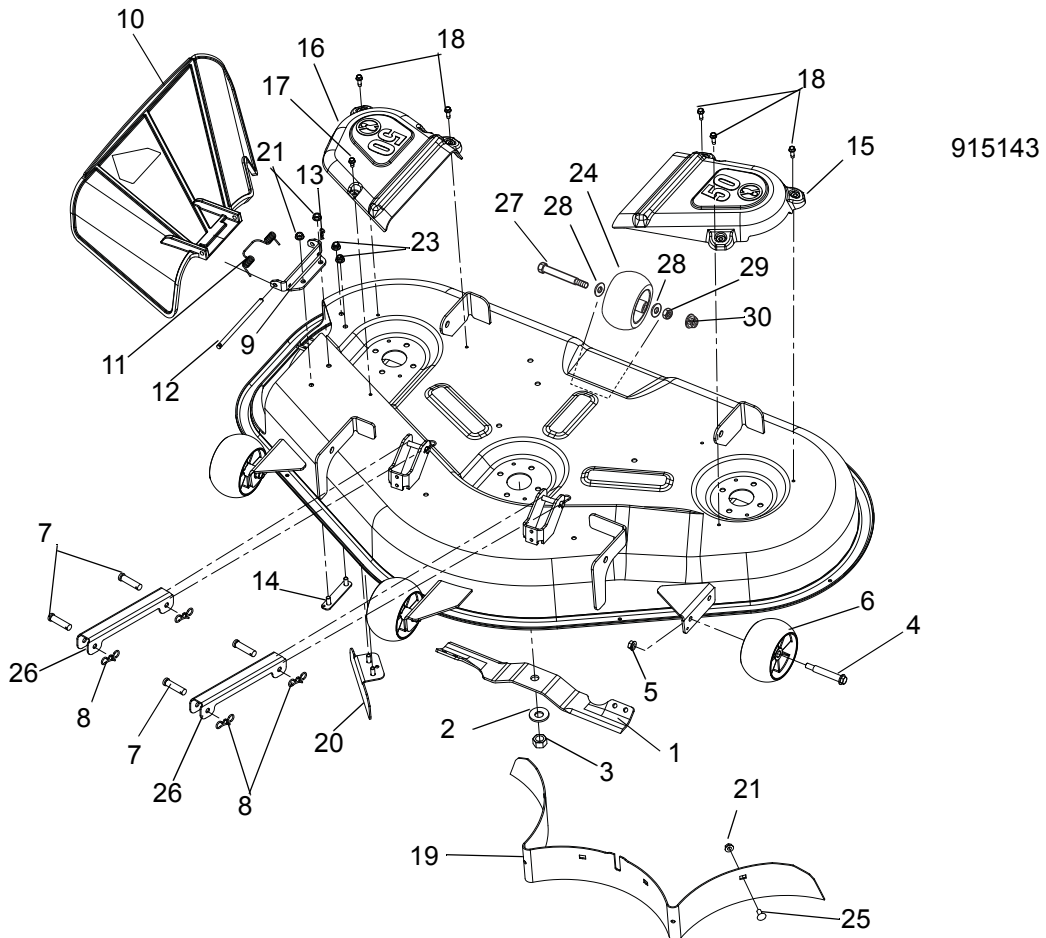
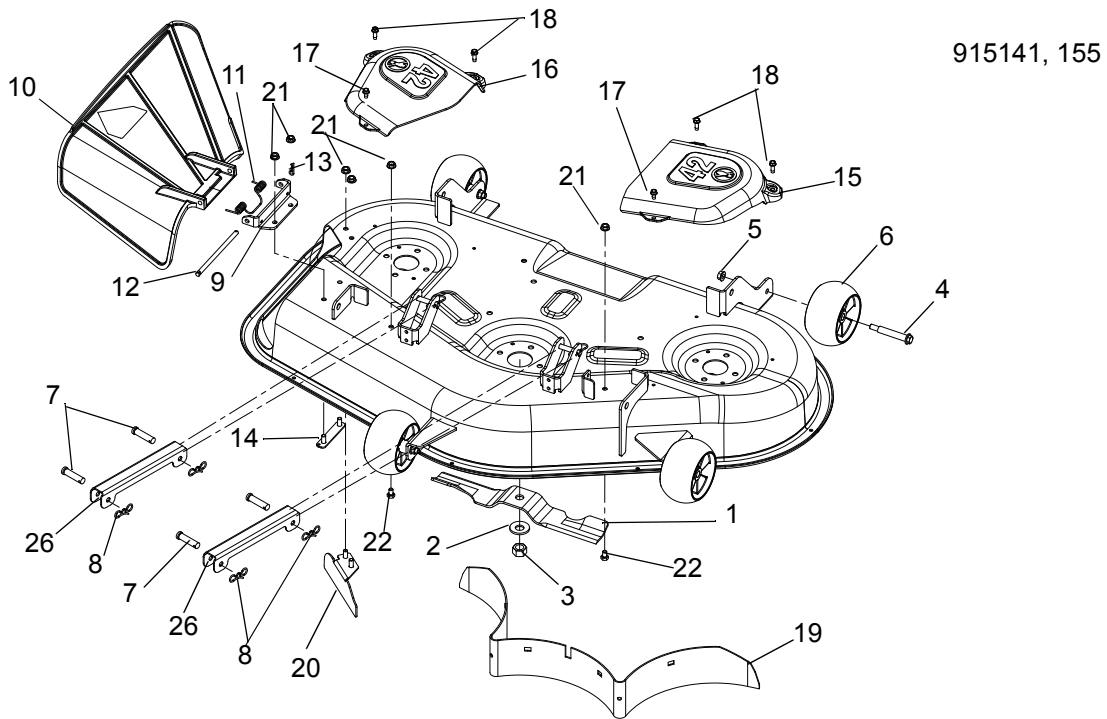

BELT COVERS AND BLADES

Model 915141, 143, 151, 155

Item	Part No.	Qty.	Description
1	03987000	3	Mower Blade, 14.83" (141, 155)
	03971900	3	Blade, Mower 17.35" (143)
2	06445700	3	Washer-Bellville .63 x 1.625 x .14
3	06500630	3	Nut, Hex .62-18
4	07056800	3	Bolt, Shoulder .38-16 x 2.50 Hex Washer Head
5	06542000	3	Nut, Locking-Top-Flange .38-16
6	03905600	4	Anti-Scalp Wheel, 5 x 3 OS (141, 155)
	03905600	3	Anti-Scalp Wheel, 5 x 3 OS (143)
7	06800102	4	Pin, Clevis .375 x 2.00
8	06700206	4	Pin, Bow Tie Locking Cotter
9	04073059	1	Bracket, Discharge Chute Mount 42" (141, 155)
	03977559	1	Bracket, Discharge Chute Mount 50" (143)
10	03902300	1	Discharge Chute
11	08300515	1	Spring, Torsion
12	00475800	1	Pin, 5/16 x 5.80"
13	06713500	1	Pin, Hair Internal .08X.18 x 1.18
14	03977400	1	Weldment, Discharge Chute MT. Strap
15	03902200	1	Belt Cover, Left Hand 42" (141, 155)
	03901900	1	Belt Cover- Left Hand 50" (143)
16	03902100	1	Belt Cover, Right Hand 42" (141, 155)
	03901800	1	Belt Cover- Right Hand 50" (143)
17	07400034	2	Screw, Tapping .25-20 x .50 Hex Washer Head (141, 155)
	07400034	1	Screw, Tapping .25-20 x .50 Hex Washer Head (143)
18	07414200	4	Screw, Tapping .25-20 x .75 Hex Washer Head
19	03957859	1	Baffle, 42 Rear (141, 155)
	04069059	1	Baffle, 50 Rear (143)
20	04044159	1	Baffle, 42" Deflector (141, 155)
	03955959	1	Baffle, 50" Deflector (143)
21	06543100	6	Nut, Locking-Top-Flange .31-18 (141, 155)
	06543100	3	Nut, Locking-Top-Flange .31-18 (143)
22	05947200	2	Bolt, Hex .31-18 x .50 Grade 5 (141, 155)
23	06545400	2	Nut, Locking-Nylon-Flange .31-18 (143)
24	02745400	1	Roller (143)
25	06220800	1	Bolt, Round Head Square Neck .31-18 x .75 Grade 5 (143)
26	03764059	2	Bracket, Stabilizer Link
27	05960900	2	Bolt, Hex .38-16 x 3.50 Grade 5
28	06436200	2	Washer, Flat-Steel .406 x .812 x .065
29	06537200	2	Nut, Locking-Center-Jam .375-16
30	06545500	1	Nut, Locking-Nylon-Flange .38-16



Ariens Company
655 West Ryan Street
P.O. Box 157
Brillion, WI 54110-0157
920-756-2141
Fax 920-756-2407
www.ariens.com