



THE KING OF SNOW®

AMP 24 Sno-Thro®

Owner/Operator Manual – Livret de l'opérateur/du propriétaire –
Betriebsanleitung – Manuale del proprietario/operatore –
Käyttöohjekirja – Manual del propietario/operador – Brukerhåndbok –
Instruktionsbok – Руководство владельца/пользователя – Instrukcja
Obsługi / Operatora – Mal Sahibi/Kullanici El Kitabı – Návod k obsluze/
pro obsluhu - Ръководство за работа за ползвателя/оператора -
Tulajdonosi/kezelői útmutató - Manualul proprietarului / operatorului -
Priručka majitel'a/obsluhy - Navodila za uporabo

Model

916302 – AMP 24



- (GB)** ENGLISH
- (BG)** БЪЛГАРСКИ
- (CZ)** ČESKY
- (SF)** SUOMI
- (F)** FRANÇAIS
- (D)** DEUTSCH
- (HU)** MAGYAR
- (I)** ITALIANO
- (N)** NORSK
- (PL)** POLSKI
- (RO)** ROMÂNĂ
- (RU)** РУССКИЙ ЯЗЫК
- (SK)** SLOVENSKY
- (SL)** SLOVENSKO
- (E)** ESPAÑOL
- (S)** SVENSKA



03982615A 3/11

Printed in USA



Ariens Company
655 West Ryan Street
Brillion, Wisconsin
54110-1072 USA
Téléphone
(920) 756-4688
Fac-simile
(920) 756-2407

EC DECLARATION OF CONFORMITY ISSUED BY THE MANUFACTURER
DECLARATION DE CONFORMITÉ CE ÉMISE PAR LE FABRICANT –
EU-ÜBEREINSTIMMUNGSERKLÄRUNG DES HERSTELLERS – DICHIARAZIONE DI
CONFORMITÀ CE RILASCIATA DAL PRODUTTORE – DECLARACIÓN DE
CONFORMIDAD CE EMITIDA POR EL FABRICANTE – EF-SAMSVARSERKLÆRING
FRA PRODUSENTEN – EG-DEKLARATIONEN OM ÖVERENSSTÄMMELSE UTFÅ
RDAD AV TILLVERKAREN – VALMISTAJAN ANTAMA EY-
VAATIMUSTENMUKAISUUSVAKUUTUS – DEKLARACJA ZGODNOŚCI Z PRZEPISAMI
EŻ WYDANA PRZEZ PRODUCENTA – ES PROHLÁŠENÍ O SHODĚ, VYDANÉ
VÝROBCEM – EO DEKLARACIJA ZA СЪОТВЕТВИЕ, ИЗДАВАНА ОТ
ПРОИЗВОДИТЕЛЯ – A GYÁRTÓ ÁLTAL KIÁLLÍTOTT EK MEGFELELŐSÉGI
NYILATKOZAT – DECLARAȚIE DE CONFORMITATE CE EMISĂ DE PRODUCĂTOR -
ES VYHLÁŠENIE O ZHODE, VYDANÉ VÝROBCOM - ES-IZJAVA O SKLADNOSTI, KI
JO JE IZDAL PROIZVAJALEC

We the undersigned, ARIENS COMPANY, certify that: Nous, soussignés ARIENS COMPANY, certifions que : Der Unterzeichnete, ARIENS COMPANY, bescheinigt, dass: La sottoscritta società ARIENS COMPANY certifica che: Nosotros, los abajo firmantes, ARIENS COMPANY, certificamos que: Undertegnede, ARIENS COMPANY, bekrefter at: Undertecknad, ARIENS COMPANY, intygar att: Allekirjoittanut, ARIENS COMPANY, vakuuttaa, että: My, nízej podpísani, ARIENS COMPANY, ošwiadczy, że: My, nížepodepsani, ARIENS COMPANY, prohlašujeme, že: Ние, долуподписаните от фирма ARIENS, удостоверяваме, че: Alulírott, ARIENS COMPANY, tanúsítja, hogy: Subsemnata ARIENS COMPANY, certifica: My, spoločnosť ARIENS COMPANY vyhlasujeme, že: Spodaj podpísani ARIENS COMPANY potrpujemo, da je:

<p>Type: Type : Typ: Tipo: Tipo: Type: Tuypri: Typ: Typ: Тип: Típus: Tip: Typ: Tip:</p>	<p>WALK BEHIND SNOW THROWER – LES CHASSES-NEIGE AUTOTRACTÉS – HANDGEFÜHRTE SCHNEEFÄHRE – SPAZZANEVE SEMOVENTE – CAMINAR POR DETRÁS DE LA LANZADORA DE NIEVE – SNØFRESER – SJÄLVGÅENDE SNÖSLUNGA – KÄSINOHJAITAVA LUMILINKO – ODGARNIACZ ŚNIEGU DO PROWADZENIA PRZED SOBĄ – SNĚHOVÁ FREZA S POJEZDEM - СНЕГОРИН С РЪЧНО УПРАВЛЕНИЕ - TOLOGATÓS HÓMARÓ – FREZÁ DE ZÁPADÁ – SNEHOVÁ FREZA S KRÁČAJÚCOU OBSLUHOU - ROČNO VODLJIVA SNEŽNA FREZA</p>
<p>Trade Name: Appellation commerciale : Handelsbezeichnung: Nome commerciale: Nombre comercial: Handelsnavn: Handelsbeteckning: Kauppanimi: Nazwa handlowa: Obchodní název: Търговско название: Kereskedelmi név: Nume comercial: Názov výrobku: Trgovsko ime:</p>	<p>Ariens</p>
<p>Model , Model Name, Serial Number: Modèle, Nom du modèle, N° de série : Modell, Modellbezeichnung, Seriennummernbereich: Model, Modelnaam, Seriennummers van tot : Model, modelnavn, serienummer: Modell, Modellnamn, Seriennummerråde: Malli, Mallin nimi, Sarjanumeroryhmä: Modell, modellnavn, serienummerråde: Modello, Denominazione modello, Numeri di serie: Modelo, Nombre, Rango N° Serie: Modelo, Nome do Modelo, Intervalo do N.º de Série: Модель, Наименование модели, Диапазон серийных номеров: Model, Nazwa modelu, Zakres numerów seryjnych: Model, Model Adi, Seri Numarası Sirası: Model, Označení, Sériové číslo: Модел, Име на модела, Серийн номер: Modell, Modellnév, Sorozatszám: Model, nume model, număr serie: Model, názov modelu, výrobné číslo: Model, ime modela, serijska številka:</p>	<p>916302, 000101+</p>

Conforms to: Est conforme à : Mit den Anforderungen der folgenden Richtlinien übereinstimmt: È conforme a: Cuple con: Er i samsvar med: Överensstämmer med: Täytää seuraavat vaatimukset: Jest zgodny z: Odpovídá směrnicím: Съответства на: Megfelel: În conformitate cu: Je v zhode s: v skladu z:

2006/42/EC, 2004/108/EC

2000/14/EC Conformity Assessment Annex V. Annexe V de l'évaluation de conformité. Konformitätsbewertung, Anhang V. Annesso V della valutazione di conformità. Anexo V de la evaluación de la conformidad. Samsvarsvurdering etter vedlegg V. Bedömning av överensstämmelse Bilaga V. Vaatimustenmukaisuuden arviointi, liite V. Dodatek V. Ocena zgodności. Posouzení shody příloha V. Оценка за съответствие 2000/14/EO Приложение V. a 2000/14/EK megfelelőség-értékelés V. mellékletének Anexa V de evaluare a conformității 2000/14/EC. Dodatkom V smernice 2000/14/EC pre posudzovanie zhody. Aneksom V za ocenitev skladnosti Direktive 2000/14/ES.

<p>Representative Measured Sound Power Level (L_{wa}) – Niveau de puissance acoustique représentatif mesuré (L_{wa}) – Repräsentativer gemessener Geräuschpegel (L_{wa}) – Livello di potenza sonora rappresentativo rilevato (L_{wa}) – Nivel de potencia acústica representativo medido (L_{wa}) – Representativ mält lydeffektivitá (L_{wa}) – Representativ uppmätt ljudnivå (L_{wa}) – Tyypillinen mitattu äänitehotaso (L_{wa}) – Zmierzony reprezentatywny poziom mocy akustycznej (L_{wa}) – Representativni hodnota změněné hladiny akustického výkonu (L_{wa}) – Представительное измерено ниво на акустична мощност (L_{wa}) – Tipikus mért hangteljesítmény (L_{wa}) – Nivel reprezentativ măsurat putere acustică (L_{wa}) – Charakteristická zmeraná hladina akustického výkonu (L_{wa}) – Tipična izmerjena raven zvočne moči (L_{wa})</p>	<p>Guaranteed Sound Power Level (L_{wa}) – Niveau de puissance acoustique garanti (L_{wa}) – Garantierter Geräuschpegel (L_{wa}) – Livello di potenza sonora garantito (L_{wa}) – Nivel de potencia acústica garantizado (L_{wa}) – Garantert lydeffektivitá (L_{wa}) – Garanterad uppmätt ljudnivå (L_{wa}) – Taattu äänitehotaso (L_{wa}) – Gwarantowany reprezentatywny poziom mocy akustycznej (L_{wa}) – Zaručovaná hodnota hladiny akustického výkonu (L_{wa}) – Гарантирано ниво на акустична мощност (L_{wa}) – Garantált hangteljesítmény (L_{wa}) – Nivel garantat putere acustică (L_{wa}) – Zaručená hladina akustického výkonu (L_{wa}) – Zajamčena raven zvočne moči (L_{wa})</p>		
916302:	87 dB _A	916302:	91 dB _A

<p>Engine Power (Kw @ RPM): Puissance moteur (kW @ tr/min) : Motorleistung (kW bei U/min): Motorvermögen (Kw @ TPM): Motoreffekt (Kw @ o/min): Motoreffekt (kW vid r/min): Moottorin teho (Kw @ RPM): Motoreffekt (Kw @ RPM): Potenza motore (kW a giri/min.): Potencia del motor (Kw a RPM): Potência do motor (Kw a rpm): Мощност двигателя (кВт - об/мин): Moc silnika (kW, obr./min.): Motor Gücü (Kw @ DEV/DAK): Výkon motoru: (kW při ot./min): Мощност на двигателя (Kw @ RPM): Motor teljesítmény (Kw @ RPM): Putere motor (Kw la RPM): Výkon motora (Kw @ RPM) (kW / ot./min.): Моć motorja (kW при vrt./min.)</p>	916302 3.0 @ 3500
---	-------------------



<p>Fred J. Moreaux: Director Product Conformance & Warranty (Keeper of Technical File) / Directeur Conformité et Garantie des produits (Gardien du fichier technique) / Direktor Produktkonformität und Gewährleistung (Aufbewahrungsstelle der technischen Dokumentation) / Directeur Productconformiteit en -garantie (Beheerder technische documentatie) / Direktor för varekonformitet och garanti och reklamation (registeransvarlig) / Direttore della conformità del prodotto e garanzia (custode del file tecnico) / Director de conformidad del producto y garantía (Responsable de la documentación técnica) / Chef för produktkonformitet och -garanti (administratör för teknisk dokumentation) / Sjef for produktsamsvar og garanti (ansvarlig for oppbevaring av den tekniske dokumentasjonen) / Tuoteyhdenmukaisuus- ja takuuosaston päälikkö (Teknisestä dokumentaatiosta vastaava) / Ürün Uyumluluk ve Garanti Müdürü (Teknik Dosya Sorumlusu) / Director da Conformidade e Garantia de Produtos (Responsável pela documentação técnica) / Ředitel shody produktů a záruky (uchovávateľ technické dokumentace) / Начальник Съответствие на продукта и Гаранция (Пазител на техническото досие) / Termék megfeleléségi és garanciális igazgató (műszaki dokumentáció tárolásának felelőse) / Director conformitate și garanție produs (responsabil fișă tehnică) / Vedúci pre zhodu a záruku výrobu (udržiavateľ súboru technickej dokumentácie) / Direktor za skladnost in garancijo izdelka (skrbnik tehnične dokumentacije)</p>	 <p>Ariens Company Brillion, WI 54110-0157 USA Signature Unterschrift Handtekening Underskrift Firma Firma Signatur Namteekning Allekirjoitus Podpis Assinatura Podpis Подпис Aláírás Semnătură Podpis Podpis</p>	<p>03/17/2011 Date Date Datum Datum Dato Data Fecha Data Datum Päiväys Data Data Datum Data Datum Dată Datum Datum</p>
<p>Guy Stewart: Authorized to Compile the Technical File/ Etablissement du fichier technique autorisé / Zur Erstellung der technischen Akte autorisiert / Bevoegd om het technische bestand samen te stellen / Autoriseret til at kompilere den tekniske fil / Behörig att kompilera den tekniska filen / Valtuutettu laatimaan teknisen tiedoston / Autorisert til å lage den tekniske filen / Autorizzato alla redazione del file tecnico / Autorizado para compilar el fichero técnico / Autorizado a compilar a documentação técnica / Упълномочен для компилирования технического файла / Osoba upraważona do sporządzenia dokumentacji technicznej / Teknik Dosyayı düzenleme izni vardir / Osoba oprávněná k sestavení technické dokumentace / Упълномощен да състави Техническото досие/ A műszaki dokumentáció összeállítására jogosult/ Autorizat pentru prelucrarea fișei tehnice/ Oprávněný na zostavenie súboru technickej dokumentácie/ Pooblaščenec za pripravo tehnične dokumentacije</p>	 <p>Ariens Company 6 Brookvale Court Sowerby Road Garstang Preston, Lancashire PR2 0TT, UK Signature Signature Unterschrift Handtekening Underskrift Firma Firma Signatur Namteekning Allekirjoitus Podpis Assinatura Podpis Подпис Aláírás Semnătură Podpis Podpis</p>	<p>03/17/2011 Date Date Datum Datum Dato Data Fecha Data Datum Päiväys Data Data Datum Data Datum Dată Datum Datum</p>

TABLE OF CONTENTS

SAFETY.....	5	STORAGE.....	30
ASSEMBLY.....	9	SERVICE PARTS.....	32
CONTROLS and FEATURES.....	13	ACCESSORIES.....	32
OPERATION.....	14	TROUBLESHOOTING.....	30
MAINTENANCE.....	19	SPECIFICATIONS.....	33
SERVICE AND ADJUSTMENTS.....	21	WARRANTY.....	34

INTRODUCTION

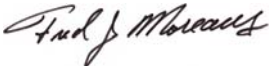
Translation of original Instructions.

MODEL AND SERIAL NUMBERS

When ordering replacement parts or making service inquiries, know the Model and Serial numbers of your unit.

Numbers are located on the product registration form in the unit literature package. They are printed on a serial number label, located on the frame of your unit.

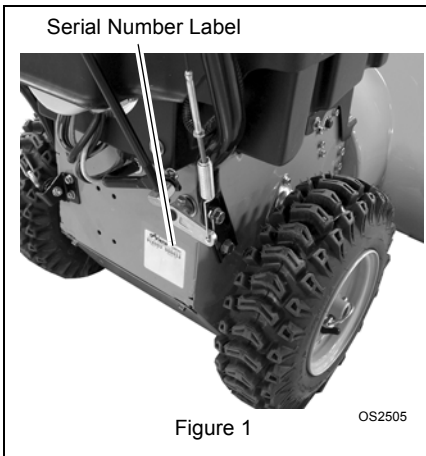

- Record Unit Model and Serial numbers here.

PRODUCT REGISTRATION

The Ariens dealer must register the product at the time of purchase. Registering the product will help the company process warranty claims or contact you with the latest service information. All claims meeting requirements during the limited warranty period will be honored, whether or not the product registration card is returned. Keep a proof of purchase if you do not register your unit.

Customer Note: If the dealer does not register your product, please fill out, sign, and return the product registration card to Ariens or go to www.ariens.com.

UNAUTHORIZED REPLACEMENT PARTS

Use only Ariens replacement parts. The replacement of any part on this vehicle with anything other than an Ariens authorized replacement part may adversely affect the performance, durability, or safety of this unit and may void the warranty. Ariens disclaims liability for any claims or damages, whether warranty, property damage, personal injury or death arising out of the use of unauthorized replacement parts. To locate your nearest Ariens Dealer, go to www.ariens.com on the internet.

DISCLAIMER

Ariens reserves the right to discontinue, make changes to, and add improvements upon its products at any time without public notice or obligation. The descriptions and specifications contained in this manual were in effect at printing. Equipment described within this manual may be optional. Some illustrations may not be applicable to your unit.

DELIVERY

Customer Note: If you have purchased this product without complete assembly and instruction by your retailer, it is your responsibility to:

1. Read and understand all assembly instructions in this manual. If you do not understand or have difficulty following the instructions, contact your nearest Ariens Dealer for assistance. Make sure all assembly has been properly completed.

NOTE: To locate your nearest Ariens Dealer, go to www.ariens.com on the Internet.



WARNING: Improper assembly or adjustments can cause serious injury.

2. Understand all Safety Precautions provided in the manuals.
3. Review control functions and operation of the unit. Do not operate the Sno-Thru unless all controls function as described in this manual.
4. Review recommended lubrication, maintenance and adjustments.
5. Review Limited Warranty Policy.
6. Fill out a Product Registration Card and return the card to the Ariens Company or go to www.ariens.com.

SAFETY



WARNING: To avoid injury to hands and feet, always disengage clutches, stop drive motor, turn off and remove key from switch and wait for all movement to stop before unclogging or working on snow thrower. Hand contact with the rotating impeller is the most common cause of injury associated with snow throwers. Never use your hand to clean out the discharge chute. Keep hands and feet away from auger and impeller.



WARNING: POTENTIALLY HAZARDOUS SITUATION! If not avoided, COULD RESULT in death or serious injury.



CAUTION: POTENTIALLY HAZARDOUS SITUATION! If not avoided, MAY RESULT in minor or moderate injury. It may also be used to alert against unsafe practices.

SAFETY ALERTS



Look for these symbols to point out important safety precautions. They mean:

Attention!



Personal Safety Is Involved!

Become Alert!

Obey The Message!

The safety alert symbols above and signal words below are used on decals and in this manual. Read and understand all safety messages.



DANGER: IMMINENTLY HAZARDOUS SITUATION! If not avoided, WILL RESULT in death or serious injury.

NOTATIONS

NOTE: General reference information for proper operation and maintenance practices.

IMPORTANT: Specific procedures or information required to prevent damage to unit or attachment.

PRACTICES AND LAWS

Practice usual and customary safe working precautions, for the benefit of yourself and others. Understand and follow all safety messages. Be alert to unsafe conditions and the possibility of minor, moderate, or serious injury or death. Learn applicable rules and laws in your area. Always follow the practices set forth in this manual.

REQUIRED OPERATOR TRAINING

Original purchaser of this unit was instructed by the seller on safe and proper operation. If unit is to be used by someone other than original purchaser; loaned, rented or sold, ALWAYS provide this manual and any needed safety training before operation.

SAFETY DECALS AND LOCATIONS

ALWAYS replace missing or damaged Safety Decals. Refer to figure below for Safety Decal locations.

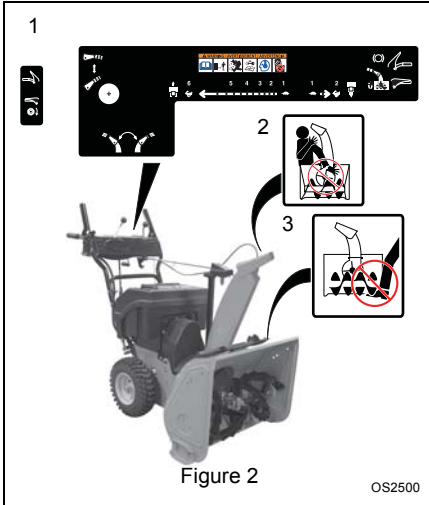

1. WARNING!



OL1801

Read Owner/Operator Manual.



OL4370

Keep people away from unit while operating. Keep children out of work area and under watchful care of a responsible adult.



OL0910

Never direct discharge towards persons or property that may be injured or damaged by thrown objects.



OL4010

Stop drive motor, remove key, read manual before making any repairs or adjustments.



OL4690

Wear appropriate hearing protection.



ONLY use clean-out tool to clear blockages. NEVER use your hands.

2. DANGER!



OS6610

ROTATING PARTS! ONLY use clean-out tool to clear blockages. NEVER use your hands. **High speed impeller rotates below discharge opening. Wait for all moving parts to stop before removing clogs or servicing.**

3. DANGER!



OS2080

ROTATING PARTS. Keep clear of auger while unit is running.

- Read Operator's Manual.
- Allow operation only by properly trained adult, never children.
- Stop drive motor and remove key prior to leaving the operator's position for any reason.
- Keep all controls, guards and safety devices properly serviced and functional.
- Never direct discharge towards persons or property that may be injured or damaged by thrown objects.

SAFETY RULES

Read, understand, and follow all safety practices in Owner/Operator Manual before beginning assembly or operating. Failure to follow instructions could result in personal injury and/or damage to unit.

ALWAYS disconnect batteries before assembly, maintenance or service.

Unintentional drive motor start up can cause death or serious injury.

Complete a walk around inspection of unit and work area to understand:

- Work area
- Your unit
- All safety decals

ALWAYS check overhead and side clearances carefully before operation.
ALWAYS be aware of traffic when operating along streets or curbs.

Keep children and people away. Keep children out of work area and under watchful care of a responsible adult.

NEVER allow children to operate or play on or near unit. Be alert and shut off unit if children enter area.

DO NOT allow adults to operate unit without proper training. Only trained adults may operate unit. Training includes actual operation.

Keep area of operation clear of all toys, pets, and debris. Thrown objects can cause injury.

Check for weak spots on docks, ramps or floors. Avoid uneven work areas and rough terrain. Stay alert for hidden hazards.

DO NOT operate near drop-offs, ditches, or embankments. Unit can suddenly turn over if a wheel is over the edge of a cliff or ditch, or if an edge caves in.

Falling snow, fog, etc. can reduce vision and cause an accident. Operate unit only when there is good visibility and light.

NEVER operate unit after or during the use of medication, drugs or alcohol. Safe operation requires your complete and unimpaired attention at all times.

NEVER allow anyone to operate this unit when their alertness or coordination is impaired.

DO NOT operate unit without wearing adequate winter outer garments. Wear adequate safety gear, including safety glasses with side shields, and protective gloves. Wear proper footwear to improve footing on slippery surfaces.

DO NOT wear loose clothing or jewelry and tie back hair that may get caught in rotating parts.

Protect eyes, face and head from objects that may be thrown from unit. Wear appropriate hearing protection.

Avoid sharp edges. Sharp edges can cut. Moving parts can cut off fingers or a hand.

ALWAYS keep hands and feet away from all rotating parts during operation. Rotating parts can cut off body parts.

NEVER place your hands or any part of your body or clothing inside or near any moving part while unit is running.

ALWAYS keep hands away from all pinch points.

DO NOT touch unit parts which might be hot from operation. Allow parts to cool before attempting to maintain, adjust or service.

Never direct discharge towards persons or property that may be injured or damaged by thrown objects. Use extreme caution on gravel surfaces. Stay alert for hidden hazards or traffic. Adjust skid shoes so Scraper Blade does not contact gravel.

DO NOT throw snow any higher than necessary.

Deflected materials can cause injury and property damage.

Always stand clear of the discharge area when operating this unit.

ALWAYS disengage attachment, stop unit, allow moving parts to stop and remove key before leaving operator's position.

ROTATING IMPELLER CAN CAUSE SERIOUS INJURY. NEVER ATTEMPT TO UNCLOG OR CLEAN UNIT WHILE AUGER IS RUNNING.

Read, understand, and follow all instructions in the manual and on the machine before starting.

Understand:

- How to operate all controls.
- The functions of all controls.
- How to STOP in an emergency.

ALWAYS allow unit to adjust to outdoor temperatures before clearing snow.

Always be sure of your footing, especially when operating in reverse or leaving the operator's position. Walk, never run during operation.

DO NOT overload the machine capacity by attempting to operate or to clear snow at too fast a rate.

Slow down and turn corners slowly.

Do not operate in reverse unless absolutely necessary. ALWAYS back up slowly. Always look down and behind before and while backing.

Disengage attachment drive when traveling from one work area to another.

Abnormal vibrations are a warning of trouble. Striking a foreign object can damage unit. Immediately stop unit. Remove key and wait for all moving parts to stop. Disconnect batteries. Inspect unit and make any necessary repairs before restart.

Before cleaning, removing clogs or making any inspections, repairs, etc.: disengage clutch(es), stop unit, remove key, allow moving parts to stop. Allow hot parts to cool.

Run auger a few minutes after clearing snow to prevent freeze-up.

Disengage attachment when not in use. Adjust skid shoes to clear gravel or crushed rock surfaces safely.

Never leave a unit unattended with key in. ALWAYS disengage attachment and remove key to prevent unauthorized use.

Never carry passengers.

Check clutch and brake operation frequently. Adjust and service as required. All motion of drive wheels and auger/impeller must stop quickly when control levers are released.

DO NOT operate on steep slopes. DO NOT clear snow across the face of slopes. Keep all movement on slopes slow and gradual. DO NOT make sudden changes in speed or direction. Use a slow speed to avoid stops or shifts on slopes. Avoid starting or stopping on a slope.

DO NOT park unit on a slope unless absolutely necessary. When parking on a slope always block the wheels.

ALWAYS remove key when transporting unit on a truck or trailer.

Use extra care when loading or unloading unit onto trailer or truck.

Secure unit chassis to transport vehicle. NEVER secure from rods or linkages that could be damaged.

Keep unit free of ice or other debris.

Before tipping unit up onto housing, remove batteries. Ensure unit is secure and will not tip over during maintenance.

ALWAYS keep protective structures, guards, and panels in good repair, in place and securely fastened. NEVER modify or remove safety devices.

ALWAYS maintain unit in safe operating condition. Check components frequently. If worn or damaged, replace with manufacturer's recommended parts.

Keep all hardware properly tightened. Check shear bolts frequently.

Maintain or replace safety and instruction labels, as necessary.

For extended storage, clean unit thoroughly. Use only attachments or accessories designed for your unit.

Do NOT put batteries in fire or mutilate.

Explosive Gases! NO flames, NO sparks, NO smoking, near batteries.

A frozen battery can explode and result in death or serious injury. DO NOT charge batteries if frozen. Thaw the battery before connecting to charger.

Poisonous battery fluid contains sulfuric acid. Contact with skin, eyes or clothing can cause severe chemical burns.

ALWAYS wear safety glasses and protective gear near batteries.

ALWAYS keep batteries out of reach of children.

Battery posts, terminals and related accessories contain lead and lead compounds, chemicals known to the State of California to cause cancer and reproductive harm. Wash hands after handling.

Charge batteries in an open, well-ventilated area, away from spark and flames. Unplug charger before connecting or disconnecting to charging port. Remove key while unit is connected to charger.

ASSEMBLY



WARNING: AVOID INJURY. Read and understand the entire *Safety* section before proceeding.



WARNING: Dropping or tipping over boxed unit could result in personal injury or damage to unit.

PACKAGE CONTENTS

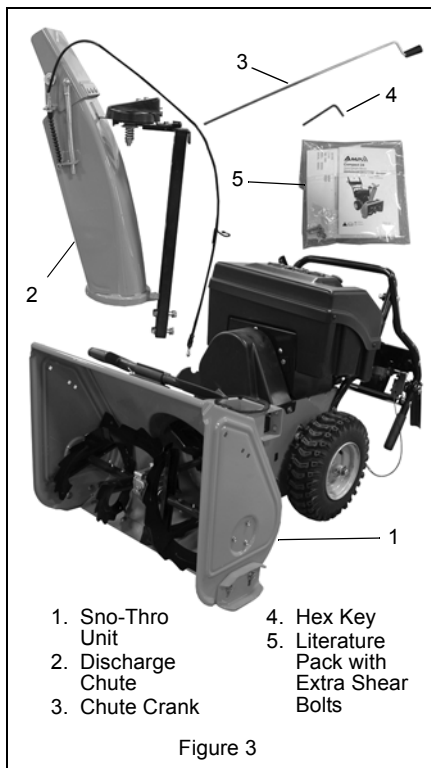

ASSEMBLY

Tools Required:

- Pliers
- Hex Key (Included)
- Open-End Wrenches: 3/8, 7/16, 1/2, 9/16 in. and/or Adjustable Wrench
- Tire Gauge

Unfold Handlebar

Figure 4

1. Remove the lower and loosen the upper hardware on the handlebar assembly.

2. Loosen the hardware on the shift rod.
3. Put the speed selector lever in the sixth forward position.
4. Rotate the handlebars into operating position.

NOTE: Be careful not to damage cable spring hooks when rotating handlebars upward.

5. Install and tighten the hardware on the handlebar assembly.
6. Tighten the hardware on the shift rod. Make sure that the rod is correctly seated before tightening.

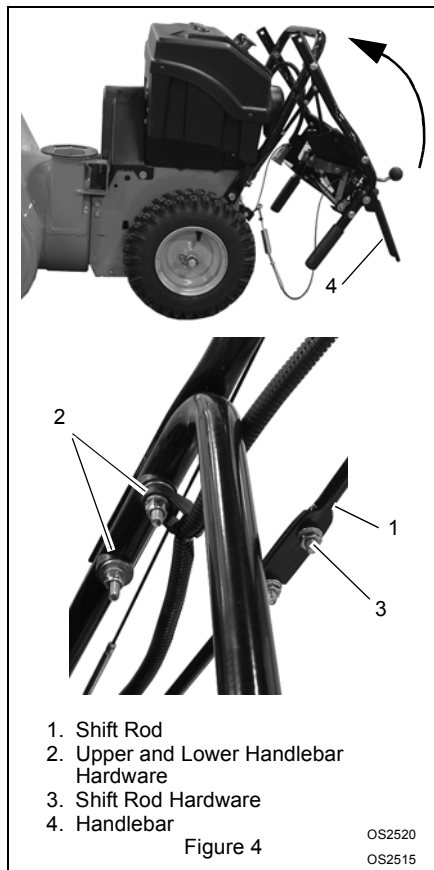

Install Discharge Chute

Figure 5

1. Grease underside of discharge chute ring (if not already greased).
2. Remove mounting hardware from the bottom of the chute pedestal.
3. Install discharge chute over opening in the auger housing and secure pedestal to auger housing with hardware removed in step 2.

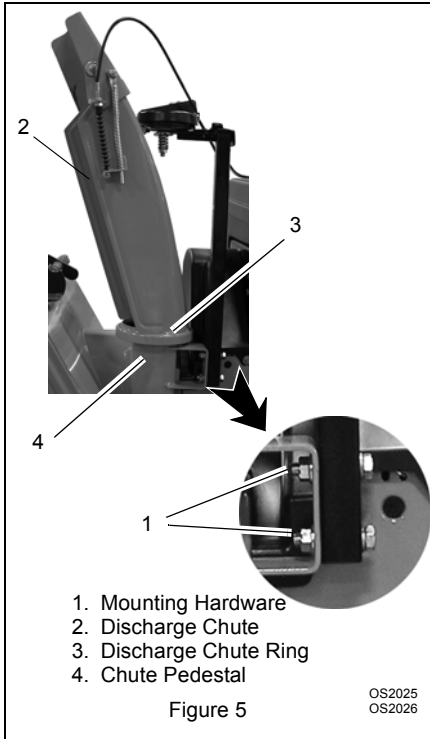

Connect Batteries

Figure 6

The battery connectors are located under the battery cover. To connect batteries:

1. Ensure that the power and PTO switches are in the OFF position.
2. Remove two hex socket head screws from each side of battery cover. Use hex key provided in literature pack.
3. Rotate cover toward handlebar. Use care not to place tension on wires.
4. Connect two batteries to power harness leads. Ensure that connectors are fully seated and lock in place.

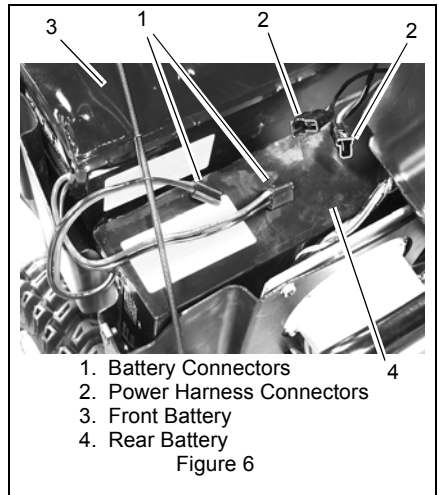

5. Install battery cover. To prevent damage to cover do not overtighten hex socket head screws.



WARNING: ALWAYS disconnect the batteries before performing maintenance on unit.

IMPORTANT: Both batteries must be disconnected to fully remove power from the electrical system.

IMPORTANT: Battery cover also acts as the hold-down for the batteries. DO NOT operate unit without the cover securely installed with all hardware.

Install Discharge Chute Crank

Figure 7

1. Slide chute crank through the opening in the control panel.

NOTE: Be careful not to damage nylon bushing when attaching crank to the dash.

2. Connect the chute crank to the pinion gear on chute with spring clip pin.

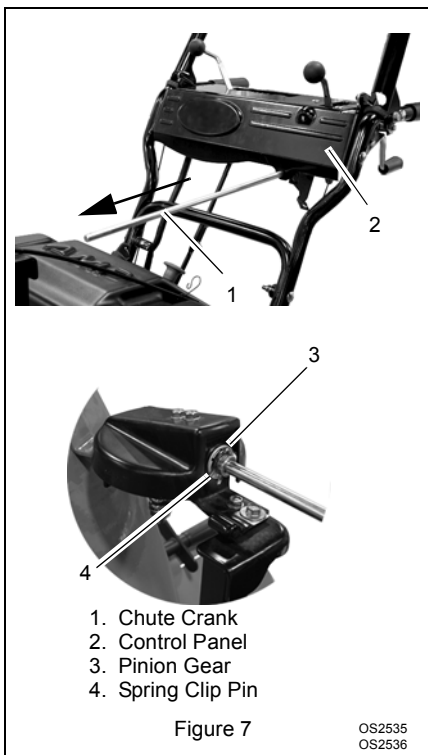

Figure 7

OS2535
OS2536

Install Remote Deflector Cable

(Figure 8 and 9)

1. Slide cable through clip on top of discharge chute pedestal Figure 8.
2. Bend clip closed around cable.
3. Using the wire hook attached to the deflector cable, hook cable to discharge chute crank.

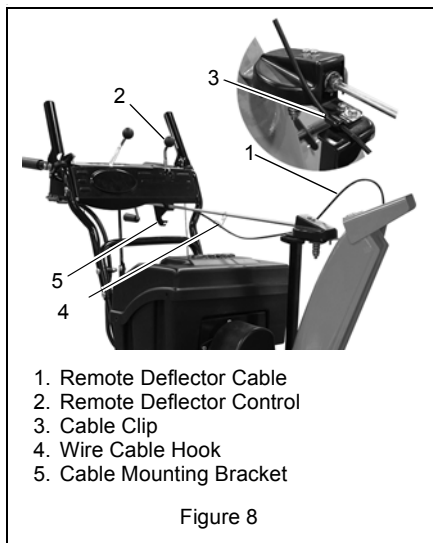
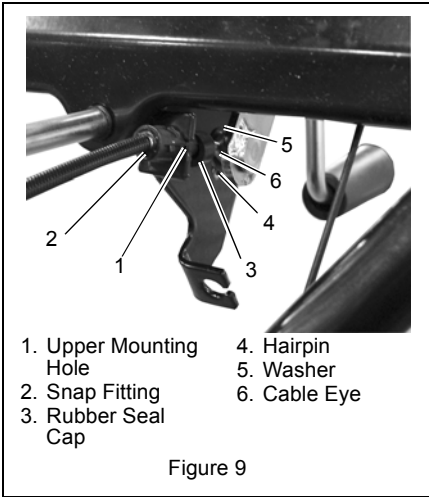

Figure 8

1. Remote Deflector Cable
2. Remote Deflector Control
3. Cable Clip
4. Wire Cable Hook
5. Cable Mounting Bracket

4. Pull rubber seal cap away from snap fitting.
 5. Install snap fitting into cable bracket's upper mounting hole.
- NOTE:** The cable mounting bracket located underneath the control panel contains two mounting holes. Use only the upper mounting hole; the one closest to the dash.
6. Position rubber seal cap over the top of snap fitting.
 7. Move deflector control lever to forward most position.
 8. Attach cable eye to pin on bottom of deflector control lever.
- NOTE:** Hold down chute deflector cap, if needed, for more cable slack.
9. Secure cable eye to control lever with washer and hairpin.
 10. Test controls to be sure deflector works properly.

NOTE: If deflector does not follow full range of travel See *Remote Discharge Deflector Control Adjustment* on page 22.



Charge Batteries

The batteries **MUST** be charged for a minimum of 7 hours before the first use.

See *Pre-Start* on page 16.

IMPORTANT: The unit **MUST** be connected to the battery charger whenever it is not in use. Failure to keep batteries fully charged will reduce battery life and void battery warranty.

Check Function of Dual Handle Interlock

With power switch in the off position, press down (engage) both clutch levers. Release pressure on attachment clutch (right side) lever. The attachment clutch should remain engaged until traction clutch lever is released, then both clutches *must* disengage. If they do not, contact your Dealer for repairs.

Check Tire Pressure

Check tire pressure and adjust to the pressure listed on tire sidewall.



CAUTION: Avoid injury! Explosive separation of tire and rim parts is possible when they are serviced incorrectly:

- Do not attempt to mount a tire without the proper equipment and experience to perform the job.
- Do not inflate the tires above the recommended pressure.
- Do not weld or heat a wheel and tire assembly. Heat can cause an increase in air pressure resulting in an explosion. Welding can structurally weaken or deform the wheel.
- Do not stand in front or over the tire assembly when inflating. Use a clip-on chuck and extension hose long enough to allow you to stand to one side.

Check Auger Gearcase Oil

Check oil level in auger gearcase (see *Check Auger Gearcase* on page 20).

Check Function of all Controls

Ensure unit runs and performs properly. Refer to *Operation*.

Run-in Attachment Belt

1. Run unit according to *Starting and Shut Off* on page 18.
2. Engage attachment clutch lever and run attachment for about 15 minutes.
3. Stop unit, wait for all moving parts to stop, and remove key.
4. Adjust clutch idler according to *Attachment Clutch/Brake Adjustment* on page 26.

CONTROLS AND FEATURES

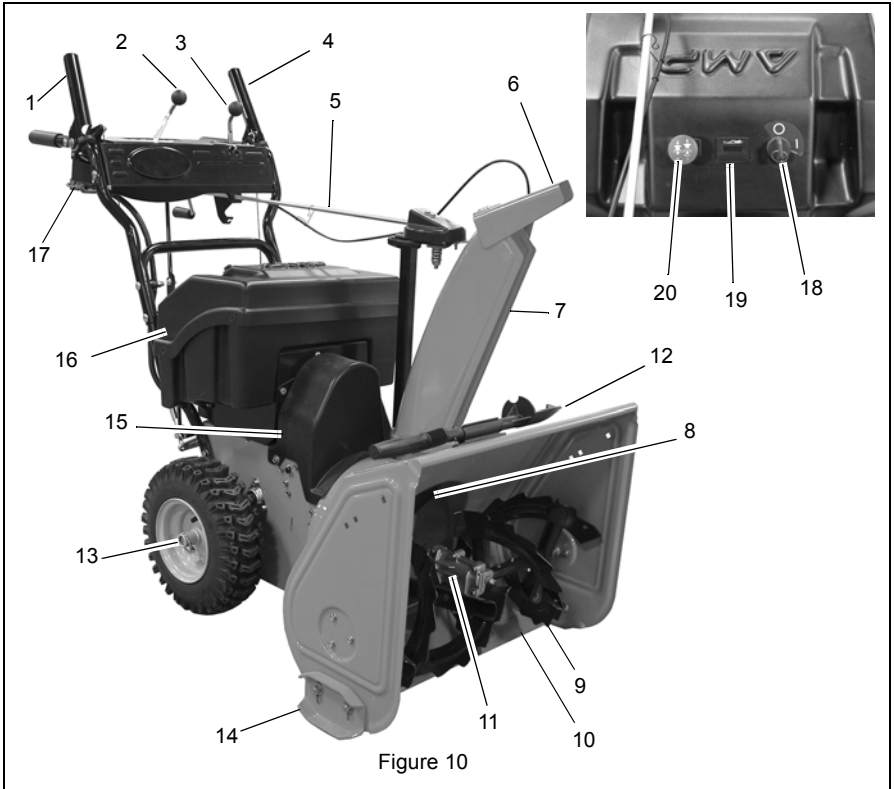

1. Attachment Clutch Lever
2. Speed Selector
3. Remote Deflector Lever
4. Traction Drive Clutch Lever
5. Chute Crank
6. Discharge Chute Deflector
7. Discharge Chute
8. Impeller
9. Auger
10. Scraper Blade
11. Auger Gearcase
12. Clean-out Tool
13. Axle Lock Pin
14. Skid Shoe(s)
15. Belt Cover
16. Battery Cover
17. Charging Port
18. Key/Power Switch
19. Battery Level Indicator
20. PTO Switch

OPERATION



WARNING: AVOID INJURY. Read and understand the entire *Safety* section before proceeding.



WARNING: To avoid injury to hands and feet, always disengage clutches, move PTO and power switches to OFF position, and wait for all movement to stop before unclogging or working on snow thrower.

Keep hands and feet away from auger and impeller.

CONTROLS AND FEATURES

See Figure 10 for all Controls and Features locations.

Dual Handle Interlock

When attachment clutch and then traction drive clutch are engaged, the attachment clutch will remain engaged (lever down) if released. To stop attachment, release traction drive clutch and both clutches will disengage.

Traction Drive Clutch – Left-Hand Lever

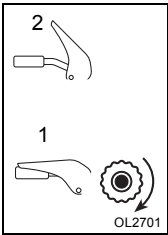

Squeeze the traction drive clutch lever against the handlebar (1) to engage wheel drive for propelling unit. Forward speed will vary according to snow depth and moisture content.

Release lever (2) to stop movement.

NOTE: When traveling to or from the area to be cleared, press down on the handlebars enough to raise the front of the unit slightly off the surface. Engage the traction drive clutch without engaging the attachment drive clutch.

Attachment Clutch – Right-Hand Lever

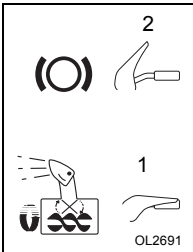

Squeeze Attachment Clutch Lever against handlebar (1) to engage attachment. Release both clutch levers (2) to disengage power and apply brake to attachment.

IMPORTANT: If the belt squeals when the attachment clutch lever is engaged, the impeller may be frozen in the auger housing. Immediately release the attachment clutch lever and move the unit into a heated area to thaw.

NOTE: If belt squeals when impeller turns freely, see *Attachment Drive Belt Replacement* on page 24.

Power Switch

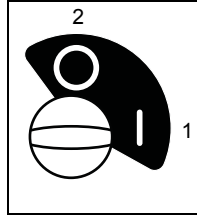

Operate power switch with a removable key. Power switch has two positions: ON (1), and OFF (2).

Always remove key when unit is unattended or connected to battery charger.

Battery Level Indicator

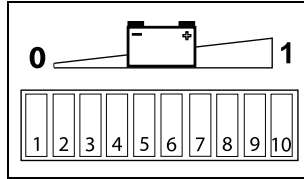

When the power switch is in the ON position one LED will light, indicating the relative

charge remaining in the batteries. When the batteries are fully charged (1) LED 10 or 9 will be lit.

During operation the lit LED will change, moving down the indicator scale as the batteries discharge.

When the batteries charge are nearly depleted (0) LED 1 and 2 will flash alternately.

NOTE: The battery level indicator will only reset once the batteries have been fully charged.

Power Take-Off (PTO) Switch

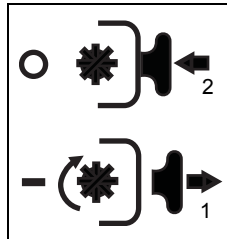

Pull out to start drive motor (1) and push in to stop drive motor (2).

Speed Selector

Position the Speed Selector in the appropriate speed notch to control forward and reverse travel.

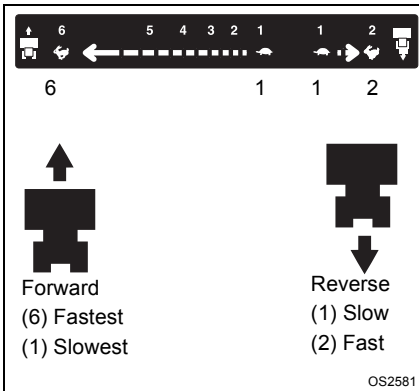

IMPORTANT: DO NOT change motion from forward to reverse with clutch engaged. Forward speed can be changed without declutching.

Snow Clean-Out Tool

Figure 11

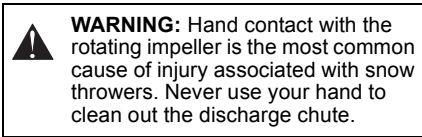

WARNING: Hand contact with the rotating impeller is the most common cause of injury associated with snow throwers. Never use your hand to clean out the discharge chute.

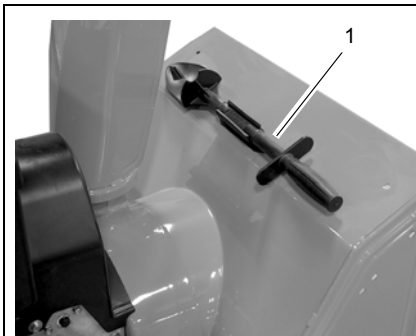

1. Snow Clean-Out Tool

Figure 11

OS2550

To clear the discharge chute:

1. Move PTO and power switches to OFF position. Remove key.
2. Wait 10 seconds and make sure impeller blades have stopped rotating.

3. Remove the snow clean-out tool (1) from the auger housing and use it to remove the clog from the discharge chute.
4. Replace the snow clean-out tool on the auger housing.

Remote Discharge Chute Deflector Control

ALWAYS position discharge chute deflector at a safe angle before engaging the auger.

Place deflector into position before operation. DO NOT throw snow any higher than necessary.

Place deflector remote in a forward notch to throw snow lower. Place deflector remote in a rearward notch to throw snow higher

Discharge Chute

Discharge chute rotates 200°.

ALWAYS position discharge chute in safe direction and angle, away from operator and bystanders, before engaging auger.

Discharge Chute Crank

IMPORTANT: If chute does not stay in set position, adjust as directed in *SERVICE AND ADJUSTMENTS* on page 21, or repair before operation.

Rotate the chute with the discharge chute crank handle.

IMPORTANT: DO NOT force frozen chute controls. If frozen, take to warm place until controls are free.

Axle Lock Pin

Figure 12

Use the axle lock pin to lock or unlock the right or left wheel. Lock both wheels to increase traction; unlock one wheel to allow for easier turning of the unit.

NOTE: Unit will not drive with both wheels unlocked.

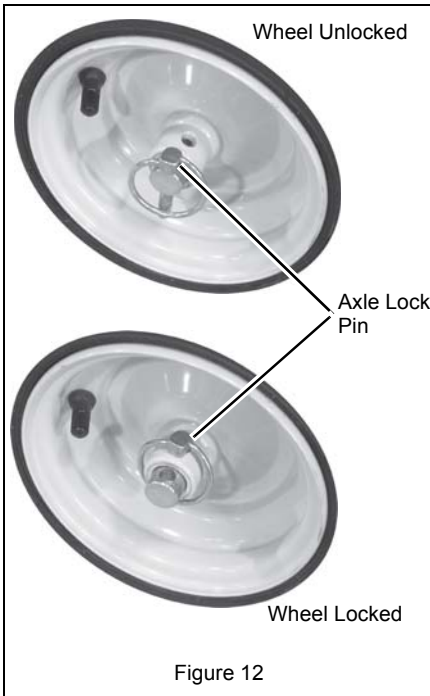

Figure 12

Scraper Blade

The scraper blade allows the back of the housing to keep better contact with the surface being cleared. It also prevents damage to the housing from normal use.

IMPORTANT: DO NOT allow scraper blade to wear too far or auger/impeller housing will become damaged.

Skid Shoes

The skid shoes control the distance between the scraper blade and the ground. Adjust skid shoes equally to keep blade level with the ground. Refer to *Check Function of Clutches* on page 17 for recommended settings.

PRE-START

Charging the Batteries

IMPORTANT: Batteries MUST be connected to battery charger after every use, regardless of length of time unit was operated. After batteries are charged the battery charger must remain connected until the next use. Failure to keep batteries fully charged will reduce battery life and void battery warranty.

Once the batteries are fully charged the attached charger switches to a hibernation mode which monitors the batteries and maintains their charge. The battery charger powers on intermittently to check voltage and charge the batteries as necessary.

If a charge is required, the battery charger sends a minimal level of current. Over time this low rate of charge helps to extend battery life by equalizing charge imbalances between cells. This low charge rate also prevents damage to the batteries from the forming of lead sulfate which occurs when batteries remain in a discharged state.

If there is a power outage while the battery charger is connected to the batteries the charger will reset once power is restored. The charger will automatically check the charge level of the batteries and reset its hibernation mode.



WARNING: FROZEN BATTERIES CAN EXPLODE and result in death or serious injury. DO NOT charge a frozen battery. Let the battery thaw before charging.



WARNING: DO NOT use battery chargers other than those recommended by an authorized Ariens dealers. Incorrect battery charging will void warranty and can lead to equipment damage, death or serious injury.

IMPORTANT: ALWAYS follow information provided with the battery charger. Contact battery charger manufacturer for detailed instructions.

1. Park unit in a well-ventilated area.
2. Turn PTO and power switches OFF. Remove key from switch.
3. Move voltage switch on bottom of battery charger to the correct voltage setting according to the wall outlet power supply. Voltage can be set to 115 or 230 volts. See Figure 13.

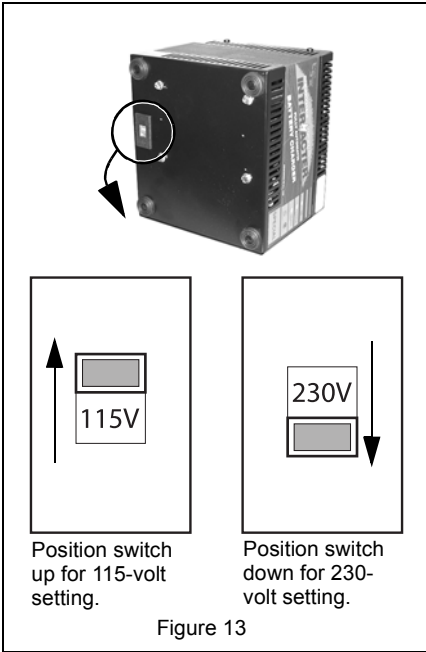

4. Attach battery charger connector to battery charging port (see Figure 14).

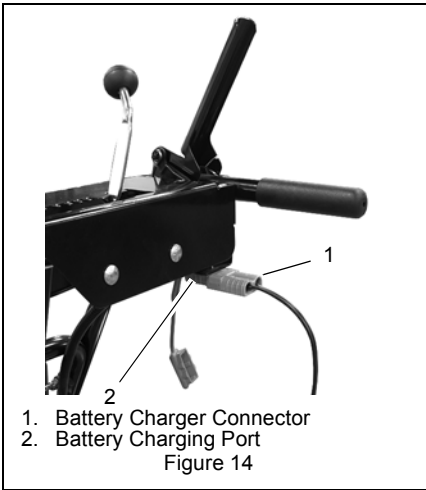

5. Plug battery charger into wall outlet. Do not use an extension cord unless necessary. If an extension cord is needed follow the manufacturer's recommendations for length and capacity.

Ensure that status indicator LEDs are lit on charger (see Figure 15). If LEDs do not light correctly refer to troubleshooting chart (see **BATTERY CHARGING TROUBLESHOOTING** on page 32).



6. Allow batteries to charge. When fully charged the green "READY" LED on the charger will light. Do not disconnect battery charger until the Sno-Thro is to be used.

NOTE: Depending on extent of discharge and battery condition, allow approximately 7 hours for a complete recharge before additional use.

7. To use Sno-Thro, disconnect battery charger from wall outlet and disconnect from unit charging port. Store charger in a dry area away from children, pets, heat and moisture.

1. Check Function of Clutches

If clutches do not engage or disengage properly, adjust or repair before operation. See *Attachment Clutch/Brake Adjustment* on page 26 and *Traction Drive Clutch Adjustment* on page 28.

2. Check Dual Handle Interlock

Without the drive motor running, press down (engage) both clutch levers. Release attachment clutch lever. Attachment clutch should remain engaged until traction clutch lever is released, then both clutches *must* disengage.

If clutches do not engage or disengage properly, adjust or repair before operation (see *Attachment Clutch/Brake Adjustment* on page 26 and *Traction Drive Clutch Adjustment* on page 28).

3. Check Axle Lock Pins

Use the axle lock pins to lock or unlock the wheels. Lock both wheels to increase traction; unlock one wheel to allow for easier turning of the unit.

4. Check Skid Shoes

Check and adjust skid shoes (*Skid Shoes* on page 21). Allow 1/8 in. (3 mm) between scraper blade and hard, smooth surface(s). Allow 1-1/4 in. (30 mm) between scraper blade and uneven or gravel surfaces.

TO STOP IN AN EMERGENCY

Immediately release both control levers to stop unit in an emergency. Disengage PTO switch, remove key and wait for all rotating parts to stop before leaving operator's position.

STARTING AND SHUT OFF



WARNING: FAILURE TO FOLLOW INSTRUCTIONS could result in personal injury and/or damage to unit. DO NOT attempt to start your unit at this time. Read entire Owner/Operator Manual first.

See Figure 10 for all Controls and Features.

Starting

IMPORTANT: Disengage PTO and release both controls before turning power switch to ON position.

1. Insert key and turn power switch to the ON position. LED in battery level indicator will glow. Drive motor will not yet run.
2. Engage PTO switch. Drive motor will run.

Stopping

1. Release traction drive clutch lever and allow unit to come to a complete stop.
2. Run impeller a few minutes after use to prevent freeze-up of Impeller.

3. Release attachment clutch lever and wait for all moving parts to come to a complete stop.
4. Disengage PTO switch. Drive motor will stop.
5. Turn power switch to OFF position and remove key.
6. Attach unit to battery charger.

NOTE: Try out each control without the drive motor running to see how it works and what it does.

SNOW REMOVAL

NOTE: Attachment clutch should be engaged before wheel drive clutch when throwing snow.

1. Select speed control position and direction.
2. Engage attachment clutch (right-hand lever).
3. Engage traction drive clutch (left-hand lever).

IMPORTANT: DO NOT overload unit capacity by attempting to clear snow at too fast a rate. Use slow speed to clear deep or hard packed snow.

Low Battery Voltage

If unit is run to the point of shutting down due to low battery voltage:

1. Disengage PTO switch and turn power switch to OFF position.
2. Manually move unit to a safe location.
3. Wait 2 – 5 minutes and move power and PTO switches to the ON position. Do not engage attachment clutch.

Batteries will regenerate enough power to drive unit back to charging area. Immediately attach battery charger to unit and charge fully.

Tips for Operation

Snow is best removed as soon as possible after snow fall.

To clear an area, run unit in an overlapping series of paths. For large areas, start in the middle and throw snow to each side, so snow is not cleared more than once.

ALWAYS direct snow away from area to be cleared and with direction of the wind.

TRAVELING

To travel from one work area to another:

1. Press down on handlebars enough to raise front of unit slightly off surface.
2. Engage traction drive clutch without engaging attachment drive clutch.

TRANSPORT

ALWAYS move PTO and power switches to OFF position and remove key when transporting unit on a truck or trailer.

Use extra care when loading or unloading unit onto trailer or truck.

Secure unit chassis to transport vehicle. NEVER secure from rods or linkages that could be damaged.

MAINTENANCE

Ariens Dealers will provide any service or adjustments which may be required to keep your unit operating at peak efficiency.



WARNING: AVOID INJURY. Read and understand the entire *Safety* section before proceeding.

SERVICE POSITION



WARNING: Before tipping unit up onto housing, both batteries must be removed from the unit. Ensure unit is secure and will not tip over during maintenance.

Remove hair pin from chute crank and remove chute crank arm. Remove both batteries and place unit on a flat level surface (see *Removing and Installing Batteries* on page 23). Tip unit forward onto front of auger housing for service. Ensure unit is secure and will not tip over. Strap and clamp onto bench if needed.



Figure 16

OS2595

MAINTENANCE SCHEDULE

The chart below shows the recommended maintenance schedule that should be performed on a regular basis. More frequent service may be required.

MAINTENANCE SCHEDULE

Service Performed	Each Use	Every 5 hrs.	Every 25 hrs.	Yearly
Charge Batteries *	•			
Check Dual Handle Interlock	•			
Check Fasteners	•			
Check Clutch Operation	•			
Check Clutch Spring Adjustments			•	
Check Tire Pressure			•	•
Check Auger Gearcase			•	•
General Lubrication			•	•

* Batteries MUST be connected to battery charger after every use, regardless of length of time unit was operated. After batteries are charged the battery charger must remain connected until the next use. Failure to keep batteries fully charged will reduce battery life and void battery warranty.

CHECK DUAL HANDLE INTERLOCK

Check operation of dual handle interlock. See *Dual Handle Interlock* on page 14.

CHECK FASTENERS

Make sure all hardware is tightened properly.

CHECK CLUTCH OPERATION

Auger and impeller must stop within 5 seconds when attachment clutch/impeller brake lever is released.

Wheels must stop quickly when traction drive clutch lever is released.

If clutches do not engage or disengage properly, adjust or repair before operation (see *Attachment Clutch/Brake Adjustment* on page 26 and *Traction Drive Clutch Adjustment* on page 28).

CHECK CLUTCH SPRING ADJUSTMENT

Make sure the attachment clutch and traction drive clutch are adjusted to the range specified in *Attachment Clutch/Brake Adjustment* on page 26 and *Traction Drive Clutch Adjustment* on page 28.

CHECK TIRE PRESSURE

Keep tires at pressure listed on the tire sidewall. (see *Check Tire Pressure* on page 12).

CHECK AUGER GEARCASE

IMPORTANT: Proper oil level must be maintained.

Gear cases are filled to the correct level at the factory. Unless there is evidence of leakage, no additional lubricant should be required. Check oil level each season or every 25 hours of operation.

To ensure adequate lubricant level:

1. Remove filler plug (Figure 17). Lubricant must be at least up to bottom of lubricant filler hole with unit resting on a level surface.
2. Add lubricant if required. Allow oil to drain to level of plug and replace plug.

IMPORTANT: Use only Ariens special gear lubricant L-2 (Part Number 00008000). Gearcase filler plug may require an application of Loctite® 565 thread sealant with repeated servicing.

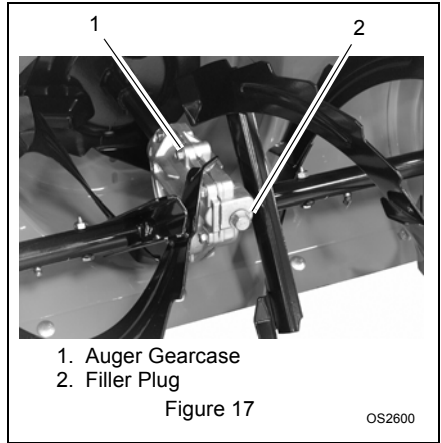

GENERAL LUBRICATION

Figure 18

IMPORTANT: Wipe each fitting clean before and after lubrication. Do not wipe gearcase filler plug; wiping the gearcase filler plug may remove thread sealant and cause leaks.

IMPORTANT: DO NOT allow grease or oil to get on friction disc, friction plate or belts.

NOTE: Apply Ariens Hi-Temp Grease or equivalent to the lubrication fittings. See *SERVICE PARTS* on page 32.

Sno-Thro should be lubricated (Figure 18) at beginning of season or every 25 operating hours.

Auger Shaft

NOTE: To grease auger shaft, remove shear bolt nuts, and shear bolts. Apply grease at the grease zerks and then turn the auger assemblies on the auger shaft. Replace shear bolts per instructions in *Shear Bolts* on page 22.

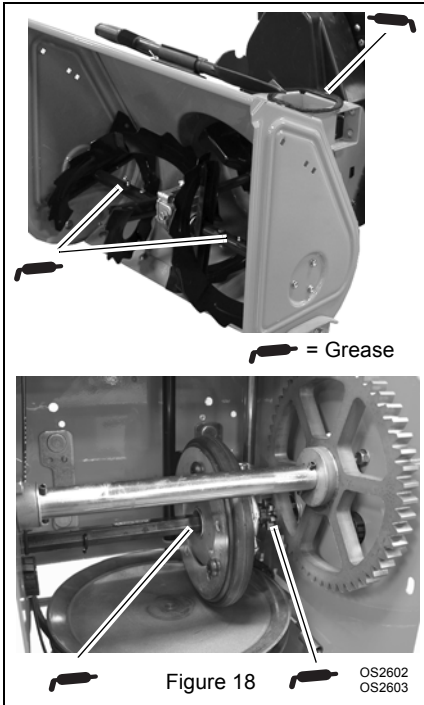

SERVICE AND ADJUSTMENTS



WARNING: AVOID INJURY. Read and understand the entire *Safety* section before proceeding.

SCRAPER BLADE

IMPORTANT: Damage to auger/impeller housing will result if blade wears down too far.

Scraper blade is adjustable to compensate for wear.

To adjust scraper blade:

1. Tip unit back onto handlebar, support housing and loosen nuts retaining scraper blade.
2. Adjust skid shoes to fully raised position (housing closest to ground).
3. Reposition scraper blade flush with skid shoes and tighten lock nuts.

SKID SHOES

Skid shoes should be adjusted as conditions require (Figure 19).

1. Position unit on a hard, flat, smooth level surface.

2. Adjust skid shoes by inserting a spacer of desired thickness under center of scraper blade.
3. Loosen skid shoe hardware.
4. Slide skid shoe to flat surface. Allow 1/8 in. (3 mm) between scraper blade and hard smooth surfaces. Allow 1-1/4 in. (30 mm) between scraper blade and uneven or gravel surfaces. Retighten hardware.

NOTE: Keep housing level by adjusting skid shoes equally.

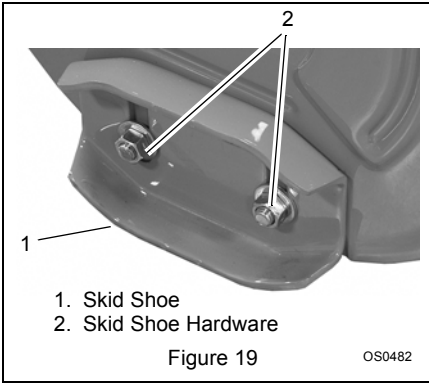

SHEAR BOLTS

IMPORTANT: Use only Ariens shear bolts for replacement. Use of any other type of shear bolt may result in severe damage to unit and may void the warranty.

Occasionally a foreign object may enter the auger/impeller housing and jam the auger, breaking the shear bolts which secure the auger to the shaft (Figure 20). This allows the auger to turn freely on the shaft which may help prevent damage to gear case and its components.

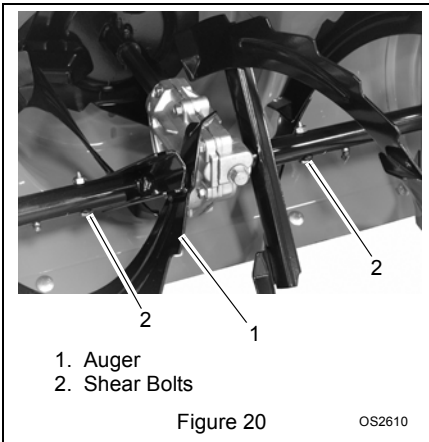

Replacement

1. Align shear bolt holes in auger with shear bolt holes in the shaft.
2. Drive shear bolt through hole. If shear bolt was broken this will drive remaining part from shaft.
3. Secure shear bolt with nut.

REMOTE DISCHARGE DEFLECTOR CONTROL ADJUSTMENT

Figure 21

If discharge deflector does not follow full range of travel:

1. Push deflector remote all the way forward.
2. Loosen adjusting nuts on remote deflector cable attached to the chute deflector (Figure 21).
3. To adjust the deflector lower:
Loosen bottom adjustment nut and tighten top adjustment nut.
To adjust deflector higher:
Loosen top adjustment nut and tighten bottom adjustment nut.
4. Check the deflectors range of travel and repeat adjustment as necessary.

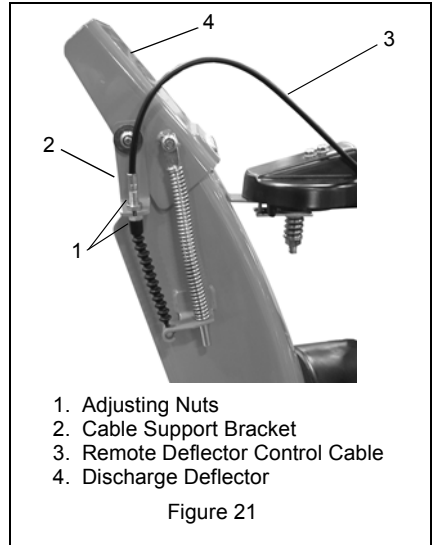

DISCHARGE CHUTE

If discharge chute does not stay in position while operating, tighten nut (2) at pivot point to increase tension on spring. See Figure 22.

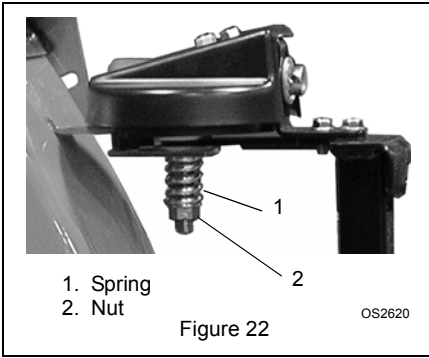

Figure 22

OS2620

REMOVING AND INSTALLING BATTERIES

Removal

1. Move power and PTO switches to the OFF position. Remove key from switch.
2. Remove four screws securing battery cover to unit and rotate battery cover toward handlebar. Use care not to place excess tension on wires.
3. Disconnect batteries from unit power harness.
4. Carefully lift batteries from battery box.

Installation

Figure 23

1. Install the rear battery into battery box standing upright with wire leads in the top left position.
2. Insert the front battery on its side into the battery box with the wire leads oriented toward the top left position.

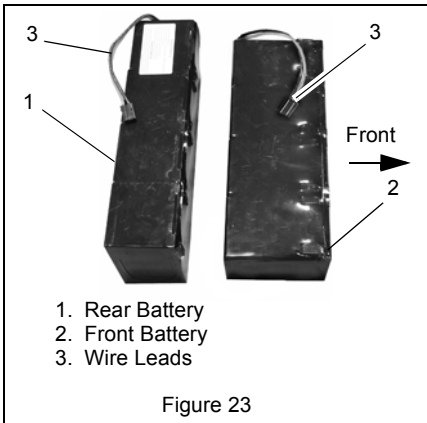

Figure 23

3. Connect batteries to power cable.
4. Install battery cover.

SPEED SELECTOR ADJUSTMENT

To adjust (Figure 24):

1. Disconnect adjustment pivot pin from speed selector arm. Save hardware for reinstallation.
2. Place the speed selector on dash panel in the fastest forward (6) speed position.
3. Turn the speed selector arm straight down towards the ground as far as it will go.
4. Thread the adjustment pivot pin along the shift rod until it aligns with the mating hole on the speed selector arm, and then turn it up the shift rod 3 turns. Insert the pivot pin into hole.
5. Connect the pivot pin to the speed selector arm with the hardware removed in step 1.
6. Check forward and reverse speeds:
 - a. Move power and PTO switches to the ON position.
 - b. Shift speed selector into the first forward speed.
 - c. Engage the traction clutch. Unit should move forward.
 - d. Release the traction clutch.
 - e. Shift speed selector into first reverse speed.
 - f. Engage the traction clutch. Unit should move backward.
 - g. Shut off unit.
7. Adjust pivot pin on the shift rod as necessary so unit travels forward when speed selector is in first forward position and travels backward when speed selector is in first reverse position.
8. Connect the pivot pin to the speed selector arm with the hardware removed in step 1.

NOTE: If first forward speed is too fast, disconnect adjustment pivot pin from speed selector arm. Rotate pivot pin to move it up the shift rod a maximum of 2 turns and reconnect pivot pin to speed selector arm.

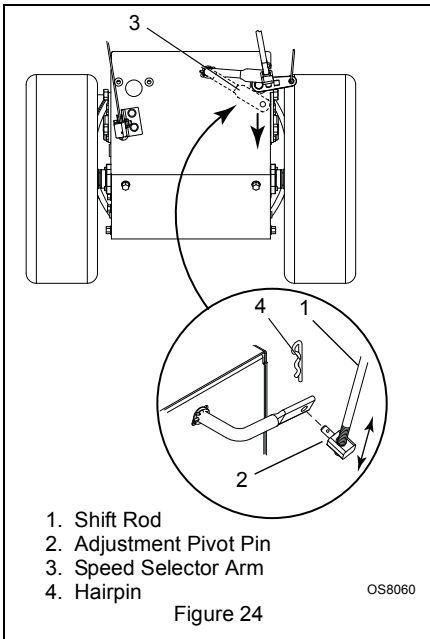

ATTACHMENT DRIVE BELT REPLACEMENT

Remove Attachment Drive Belt

(Figures 25, 26 and 27)

1. Move power and PTO switches to the OFF position. Remove key.
2. Disconnect batteries.
3. Loosen the hardware securing belt cover to unit.

NOTE: DO NOT completely remove the hardware from unit.

4. Remove the belt cover.
5. Remove spring pin from chute crank and separate.
6. Remove remote deflector control cable from dash control.
7. Remove belt fingers by removing hex bolts mounting belt fingers to frame. See Figure 25.
8. Remove attachment drive belt from drive pulley.



CAUTION: Always support Sno-Thro frame and housing when loosening the cap screws holding them together. Never loosen cap screws while unit is in service position.

IMPORTANT: To avoid bending bottom cover, when tipping unit apart, support handlebars firmly or tip unit up on housing and remove bottom cover by removing six cap screws before separating unit.



WARNING: Before tipping unit up onto housing, both batteries must be removed from the unit. Ensure unit is secure and will not tip over during maintenance.

9. Support Sno-Thro frame and housing.
10. Remove hex bolts securing housing to frame (two on each side). Tip housing and frame apart on pivot pin. See Figure 26.
11. Remove attachment drive belt from attachment pulley (hold brake away from belt).

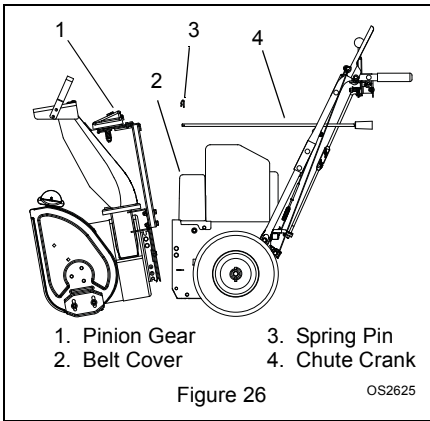

Replace Attachment Drive Belt

1. Place new belt onto attachment pulley.

NOTE: Hold down the attachment clutch lever to make it easier to reconnect the housing and frame.

2. Tip housing and frame back together and secure with hex bolts.
3. Place belt onto drive pulley.
4. Replace belt fingers. Ensure that index pins are properly seated.
5. Adjust clutch per *Attachment Clutch/Brake Adjustment* on page 26.



WARNING: AVOID INJURY. Auger must stop within 5 seconds when attachment lever is released or serious injury or unit damage may result.

6. Replace chute crank and secure with spring pin.
7. Reconnect remote deflector cable to dash control.
8. Run in the attachment belt. See *Run-in Attachment Belt* on page 12.
9. Replace belt cover.

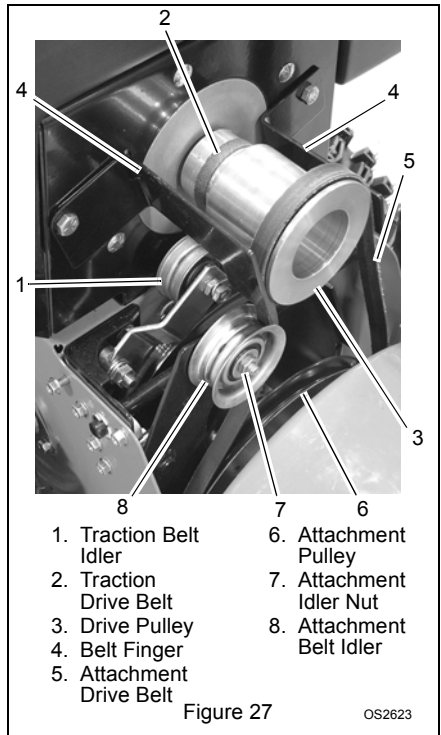

TRACTION DRIVE BELT REPLACEMENT

1. Move PTO and power switches to OFF position.
2. Disconnect and remove batteries.



CAUTION: Before tipping unit up onto housing, both batteries must be removed from the unit. Ensure unit is secure and will not tip over during maintenance.

3. Place the unit into the service position on a level surface (see *Service Position* on page 19).
4. Remove the bottom cover by removing six cap screws.

NOTE: To gain belt clearance, remove swing gate spacer (Figure 28) so drive plate can be slid over until finger is out of frame and drive plate can swing past stop hole in frame. See Figure 29.

ATTACHMENT CLUTCH/BRAKE ADJUSTMENT



WARNING: IMPROPER ADJUSTMENT could result in unexpected movement of auger and impeller causing death or serious injury. **AUGER / IMPELLER MUST STOP** within 5 seconds when Attachment Clutch/Impeller Brake Lever is released.

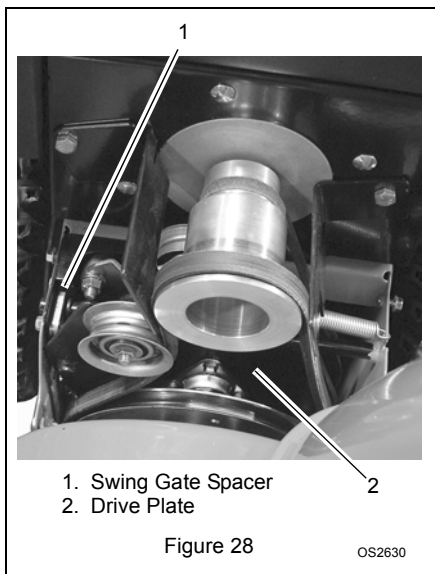

1. Swing Gate Spacer
2. Drive Plate

Figure 28

OS2630

Remove Attachment Cable Slack

1. Loosen the hardware securing belt cover to unit.

NOTE: DO NOT completely remove the hardware from unit.

1. Remove the belt cover.
2. Loosen jam nut (3) on cable adjustment barrel (2), and then turn the adjustment barrel down to shorten cable and remove all cable slack. See Figure 30.

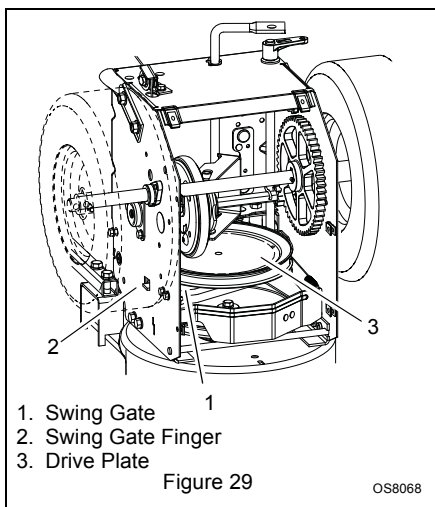

1. Swing Gate
2. Swing Gate Finger
3. Drive Plate

Figure 29

OS8068

5. Pull idler away from traction drive belt and remove belt from idler, drive pulley and driven pulley.
6. Replace traction drive belt.
7. Swing drive plate toward friction disc to slide finger into stop hole in frame. Reinstall swing gate spacer.

NOTE: Make sure drive plate spring remains connected to the frame and drive plate.

8. Replace attachment drive belt (See *Replace Attachment Drive Belt* on page 25).

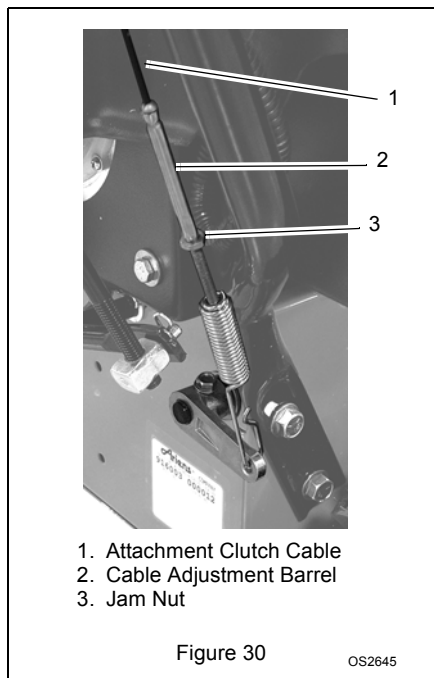

1. Attachment Clutch Cable
2. Cable Adjustment Barrel
3. Jam Nut

Figure 30

OS2645

3. With the attachment clutch disengaged, check that the attachment idler arm lightly touches the frame. See Figure 31.
4. Tighten jam nut on cable adjustment barrel.

With the attachment clutch disengaged, check the attachment idler arm position here. The attachment idler arm should lightly touch the frame.



1. Attachment Idler Arm

Figure 31

OS7188

Check Attachment Idler Arm Roller Clearance

1. Place the unit into the service position (see *Service Position* on page 19). Remove the bottom cover.
2. With the clutch lever engaged, check the clearance between the frame and plastic roller on the lower end of the attachment idler arm. See Figure 32.
 - If roller is $1/2 - 7/8$ in. (12.7 – 22.2 mm) from frame, go to *Adjust the Attachment Clutch Cable Spring Extension* on page 27.
 - If roller is less than $1/2$ in. (12.7 mm) from frame, loosen idler adjustment nut and move idler closer to the belt. Tighten adjustment nut and recheck the roller clearance.
 - If roller is more than $7/8$ in. (22.2 mm) from frame, loosen idler adjustment nut and move idler away from the belt. Tighten adjustment nut and recheck roller clearance.

Roller should be $1/2 - 7/8$ in. (12.7 – 22.2 mm) from the frame when the attachment clutch is engaged.

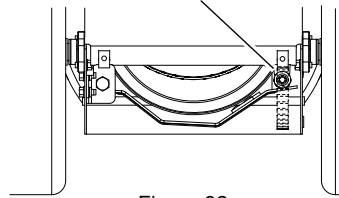
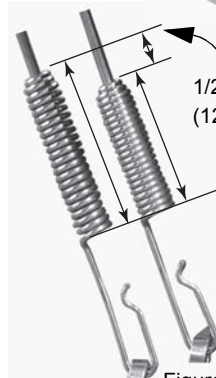
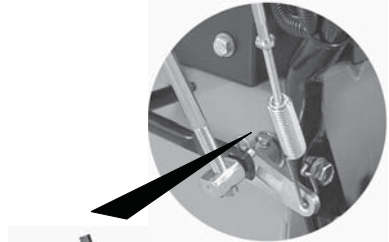

Figure 32

OS8080

Adjust the Attachment Clutch Cable Spring Extension

1. Check the attachment clutch cable spring extension. Measure the length of the attachment clutch cable spring with the clutch lever disengaged. Then measure the attachment clutch spring with the clutch lever engaged. See Figure 33. The spring should be $1/2 - 9/16$ in. (12.7 – 14.3 mm) longer when the clutch lever is engaged.
 - If spring extension is within the specified range, go to *Check Attachment Brake* on page 28.
 - If spring extension is outside of specified range, go to step 2.



$1/2 - 9/16$ in.
(12.7 – 14.3 mm)

Figure 33

OS8085

2. Adjust cable length (See Figure 33).
 - a. Loosen jam nut on cable.
 - b. To increase spring extension, adjust barrel down the cable and tighten jam nut.
 - c. To decrease spring extension, adjust barrel up the cable and tighten jam nut.

Check Attachment Brake

Figure 34

1. With the clutch lever disengaged, brake pad must contact attachment belt. With clutch lever engaged, brake pad must be more than 1/16 in. (1.6 mm) from belt. If there is more than 1/16 in. (1.6 mm) gap, go to *Traction Drive Clutch Adjustment* on page 28. If there is less than 1/16 in. (1.6 mm) gap, go to Step 2.

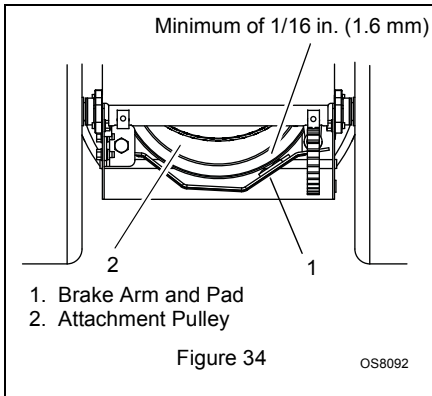

2. If there is less than 1/16 in. (1.6 mm) gap between brake pad and belt, follow these steps:
 - a. To increase brake pad gap, loosen idler adjustment nut, and move idler away from belt. Position idler to achieve a 1/16 in. (1.6 mm) minimum brake pad gap and a 1/2 – 7/8 in. (12.7 – 22.2 mm) gap between the plastic roller and the frame.
 - b. Check the clutch cable spring extension and adjust as necessary to achieve a 1/2 – 9/16 in. (12.7 – 14.3 mm) spring extension.
 - c. If the cable needed adjustment, recheck gaps described in step 1. Repeat steps as necessary until brake clearance, roller gap and spring extension are within specified ranges.

IMPORTANT: If adjustments cannot be brought into specified ranges see your Dealer for repairs.

TRACTION DRIVE CLUTCH ADJUSTMENT

If drive slips, adjust traction clutch to compensate for friction disc wear.

To test traction clutch (Figure 35):

1. Put unit in first forward speed.
2. With power switch off, push unit forward while slowly moving the traction drive clutch lever toward the handlebar.
3. Measure distance between lever and handlebar when the wheels begin to brake. If distance is not 7-1/2 – 8 in. (19.0 – 20.3 cm), adjust the traction clutch.

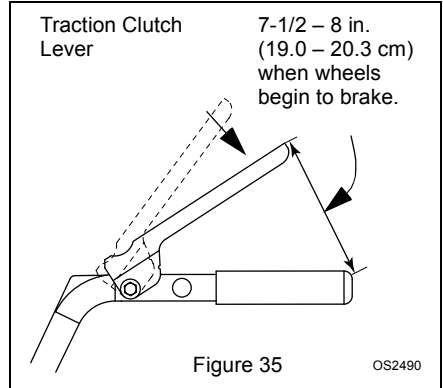

To adjust traction clutch (Figure 36):

1. With the traction drive clutch lever disengaged, loosen the jam nut on the cable adjuster. Turn adjustment barrel up the cable to decrease the distance between clutch lever and handlebar. Turn the adjustment barrel down the cable to increase the distance between clutch lever and handlebar.
2. Check traction clutch lever distance and repeat adjustment steps if necessary.
3. Tighten jam nut on traction cable adjustment barrel.
4. With the clutch disengaged, check that there is more than 1/32 in. (0.8 mm) clearance between friction disc and drive plate assembly. See Figure 37 on page 29.

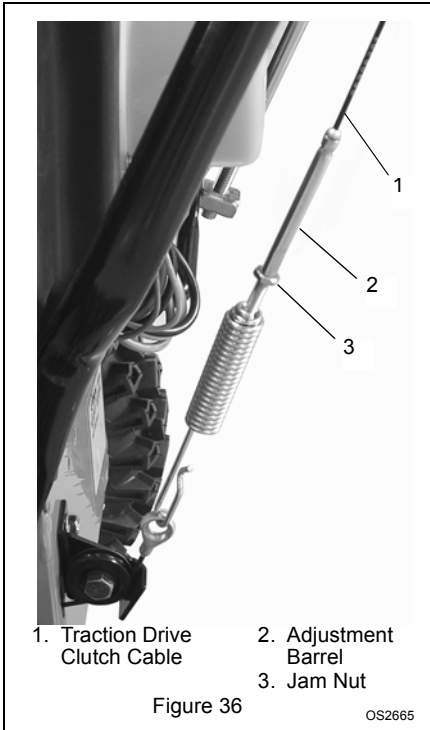

FRICTION DISC REPLACEMENT

Remove Friction Disc

Figure 37

1. Move PTO and power switches to OFF position. Remove key.
2. Disconnect and remove batteries.



CAUTION: Before tipping unit up onto housing, both batteries must be removed from the unit. Ensure unit is secure and will not tip over during maintenance.

3. Place the unit into the service position on a level surface (see *Service Position* on page 19).
4. Remove lockpins from wheel axles and remove wheels.
5. Remove bottom cover by removing six hex bolts.
6. Disconnect pivot pin from the speed selector arm. Save the hardware for reinstallation.
7. Remove spring clip pin nearest drive gear from hex shaft.
8. Remove left bearing flange from frame.

9. Slide hex shaft to the left to remove the flat washer, pinion gear and friction disc assembly from the hex shaft.

NOTE: Be sure to save washers between bearing and sliding fork for reassembly.

10. Remove friction disc assembly from frame.
11. Remove three screws holding friction disc to carrier bearing.
12. Remove old friction disc. Put the new friction disc in place, cup side to carrier bearing.
13. Reinstall three screws into new friction disc and carrier bearing. Torque to 5 – 6 lbf-ft. (6.8 – 8.13 N•m).

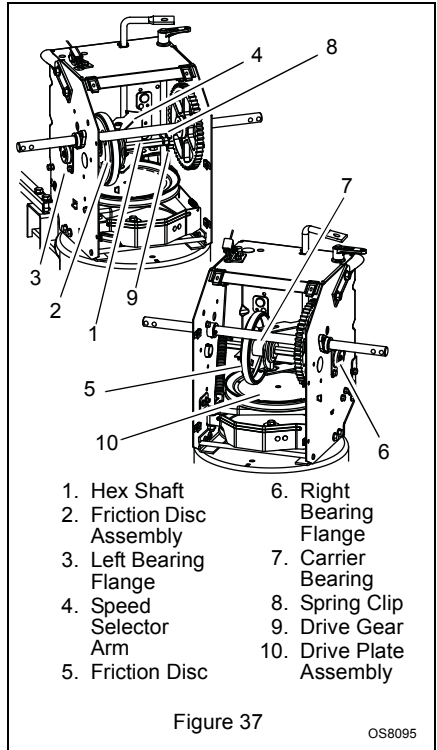

14. Insert new friction disc assembly into frame. Install washers onto carrier bearing and slide into speed selector arm.
15. Slide hex shaft through new friction plate assembly. Install pinion gear and washer onto hex shaft and slide shaft into right bearing.
16. Install left bearing using hardware removed in step 8.
17. Reinstall clip pin into hex shaft.

18. Connect pivot pin to speed selector arm. See *Speed Selector Adjustment* on page 23.
19. Install bottom cover.
20. Install wheels.

21. Return unit to upright position.
22. Install and connect batteries.
23. Adjust traction drive clutch. See *Traction Drive Clutch Adjustment* on page 28.

STORAGE



WARNING: AVOID INJURY. Read and understand the entire *Safety* section before proceeding.

SHORT TERM

Maintain battery charge.

IMPORTANT: Always keep battery charger connected to batteries and a reliable power source when Sno-Thro is not in use. Failure to keep batteries fully charged will reduce battery life and void battery warranty.

Run with attachment clutch engaged a few minutes after each use to free unit of any loose or melting snow.

Remove key from switch.

Inspect unit for visible signs of wear, breakage or damage.

Keep all nuts, bolts and screws properly tightened and know unit is in safe working condition.

Store unit in a cool, dry protected area.

LONG TERM

Follow all instructions under Short-Term storage.

Clean unit thoroughly and lubricate (see *MAINTENANCE* on page 19).

Touch up all scratched painted surfaces.

Remove weight from wheels by putting blocks under frame or axle.

TROUBLESHOOTING

PROBLEM	PROBABLE CAUSE	CORRECTION
Drive motor will not run.	<ol style="list-style-type: none"> 1. PTO switch in ON position when key turned ON. 2. Traction or attachment clutch levers engaged. 3. Discharged batteries. 4. Disconnected batteries. 5. Faulty electrical system. 6. Drive motor stops when attachment lever is engaged. 	<ol style="list-style-type: none"> 1. Turn PTO switch OFF before turning key switch ON. 2. Release levers. 3. Charge batteries (see <i>Charging the Batteries</i> on page 16). 4. Connect both batteries to power harness. 5. Contact your Ariens Dealer 6. Charge batteries – Controller senses low battery voltage (see <i>Low Battery Voltage</i> on page 18).
Does not operate in Forward / Reverse.	<ol style="list-style-type: none"> 1. Friction disc not adjusted properly. 2. Traction belt not functioning. 3. Speed selector not adjusted properly. 4. Discharged batteries. 	<ol style="list-style-type: none"> 1. Repair or replace friction disc (see <i>Friction Disc Replacement</i> on page 29). 2. Repair or replace traction drive belt (see <i>Traction Drive Belt Replacement</i> on page 25). 3. Adjust speed selector (see <i>Speed Selector Adjustment</i> on page 23). 4. Charge batteries – Controller senses low battery voltage (see <i>Low Battery Voltage</i> on page 18).
Small rubber beads collect in frame.	<ol style="list-style-type: none"> 1. Friction disc wear. 	<ol style="list-style-type: none"> 1. Normal friction disc wear. Chunks or large pieces of rubber mean friction disc should be checked and replaced as necessary.

TROUBLESHOOTING

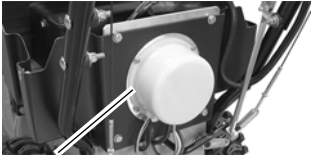
PROBLEM	PROBABLE CAUSE	CORRECTION
Unit throws snow poorly or does not throw snow.	<ol style="list-style-type: none"> 1. Shear bolts broken. 2. Attachment clutch/brake not adjusted properly. 3. Auger is frozen in place. 4. Ice or debris is obstructing auger. 5. Attachment drive belt slipping, worn or damaged. 	<ol style="list-style-type: none"> 1. Replace shear bolts (<i>see Shear Bolts</i> on page 22). 2. Adjust attachment clutch/brake (<i>see Attachment Clutch/Brake Adjustment</i> on page 26). 3. Move unit to a warm place to thaw. 4. Move PTO and key switches to OFF position. Remove key from switch. Clear blockage from auger or chute (<i>see Snow Clean-Out Tool</i> on page 15). 5. Adjust or replace attachment drive belt (<i>see Attachment Clutch/Brake Adjustment</i> on page 26).
Controller displays flashing red light under the cover.	<ol style="list-style-type: none"> 1. A trouble code has been set in the electrical system: <div style="margin-left: 20px;"> = long flash = short flash </div> <div style="text-align: center; margin: 10px 0;">  </div> <p style="text-align: center;">Controller</p> <p>Code:</p> <ol style="list-style-type: none"> 1. (Motor Coil Overheated) 2. (Motor Position Error) 3. (Controller Overheated) 4. (Low System Voltage) 5. (Stall Mode) 	<p>Perform the suggested correction. If trouble code resumes contact your Ariens Dealer.</p> <ol style="list-style-type: none"> 1. Turn key to OFF position, allow unit to fully cool before resuming. 2. Contact your Ariens Dealer. 3. Turn key to OFF position, allow unit to fully cool before resuming. 4. Charge batteries (<i>see Low Battery Voltage</i> on page 18). 5. Move PTO and key switches to OFF position. Remove key from switch. Clear blockage from auger or chute (<i>see Snow Clean-Out Tool</i> on page 15). <p>NOTE: Unit must be OFF for a minimum of 30 seconds before resuming.</p>

BATTERY CHARGING TROUBLESHOOTING

PROBLEM	PROBABLE CAUSE	CORRECTION
Battery charger LED indicators do not light.	<ol style="list-style-type: none"> 1. No power to battery charger. 2. Battery charger cord not properly connected to charger. 3. Faulty battery charger. 	<ol style="list-style-type: none"> 1. Check power source. 2. Ensure that battery charger cord is properly connected. 3. Contact your Ariens Dealer.
Yellow LED does not light.	<ol style="list-style-type: none"> 1. Battery charger not properly connected to power cable. 2. Batteries not connected to power harness. 3. Defective cable between battery charger and batteries. 4. Faulty battery or batteries. 	<ol style="list-style-type: none"> 1. Ensure proper connection. 2. Ensure that batteries are properly connected to power harness. 3. Inspect and replace faulty cables on unit or replace battery charger. 4. Replace defective battery or batteries (see <i>Removing and Installing Batteries</i> on page 23).
Green "READY" LED on battery charger does not light after 7 hours.	<ol style="list-style-type: none"> 1. Battery charger connector not seated in charging port. 2. Faulty battery or batteries. 	<ol style="list-style-type: none"> 1. Insert battery charger connector completely into charging port. 2. Replace defective battery or batteries (see <i>Removing and Installing Batteries</i> on page 23).
Green "READY" LED on battery charger flashes.	<ol style="list-style-type: none"> 1. Faulty battery or batteries. 	<ol style="list-style-type: none"> 1. Replace defective battery or batteries (see <i>Removing and Installing Batteries</i> on page 23).

SERVICE PARTS

Order the following parts through your Dealer:	
Part No.	Description
03793500	Battery Sub-Pack
03822300	Battery Charger (Standard)
07200513	Impeller Belt
07200110	Traction Belt
53200500	Shear Bolts
00170800	Friction Disc
00036800	Ariens Hi-Temp Grease (3, 3 oz. cartridges)

ACCESSORIES

See your authorized Ariens dealer to add the additional accessories available to your Sno-Thro model.	
Part No.	Description
73203100	Slicer Bar
72406500	Front Weight Kit
72600300	Composite Skid Shoe Kit
73203600	Sno-Thro Cover

SPECIFICATIONS

Model Number	916302
Description	AMP 24
Motor	
Type	Electric Brushless DC
Electrical	
Battery	48 Volt Maintenance Free VRLA
PTO (Power Take Off)	Electric Motor Control
Chute	
Chute Rotation Angle	200°
Rotation Control	2.5X Quick Turn
Deflector Control	Remote
Auger	
Snow Clearing Width – cm	61,0
Gear Case	Aluminum
Auger Diameter – cm	27,90
Housing Height – cm	44,50
Impeller	
Impeller Diameter – in. (cm)	30,5
Impeller Speed – No Load (RPM)	1330
Drive	
Blower Drive	HA Belt
Drive System	Disc-O-Matic®
Speeds	6 Forward and 2 Reverse
Axle Control	Pin-Lock
Pneumatic Tires – in.	13 x 4-6
Size and Weight	
Length – cm	134,6
Height – cm	111,8
Width – cm	67,3
Weight – Kg	105,2
CE Sound and Vibration (Ref. EN836-2001)	
Oper. Ear Sound Pressure (Lpa) in dBA	73
Vibration Measure (m/sec ²) at Operator Hands	.61
Warranty	See warranty statement



Sno-Thro[®], Sno-Tek[®] and Chore Performing Equipment Limited Warranty

Ariens Company (Ariens) warrants to the **original purchaser** that Ariens, Gravely, Parker, and Countax brand chore performing equipment (including Sno-Thro[®] and Sno-Tek[®] equipment) purchased on or after 1/1/2011 will be free from defects in material and workmanship for the time period noted in the chart below. Equipment put to personal use around a single household or residence is considered "Consumer Use"; equipment put to any business use (agricultural, commercial, or industrial) or used at multiple locations is considered "Commercial Use." If any product is rented or leased, then the duration of these warranties shall be 90 days after the date of purchase.

An authorized Ariens dealer (Ariens brand products), Gravely dealer (Gravely brand products), Parker dealer (Parker brand products), or Countax dealer (Countax brand products) will repair any defect in material or workmanship, and repair or replace any defective part, subject to the conditions, limitations and exclusions set forth herein. Such repair or replacement will be free of charge (labor and parts) to the original purchaser except as noted below.

Warranty Code	Product Group	Warranty Period Consumer Use	Warranty Period Commercial Use
PA	Log Splitters, Brushes, String Trimmers, Edgers	3 Years	90 Days
PB	Professional Powered Brushes	3 Years	1 Year
PC	Tillers	2 Years	90 Days
PD	Vacuums, Blowers, Sweepers, Truck Loaders, Lawn Rakes, Sprayers, Aerators, etc.	1 Year	1 Year
SA	Professional Sno-Thro [®]	3 Years	1 Year
SB	Compact, Deluxe, Platinum, AMP [™] Sno-Thro [®]	3 Years	90 Days
SC	Sno-Tek [®]	2 Years	90 Days
UA	Utility Vehicles	1 Year	1 Year
N/A	Service (Replacement) Parts	90 Days (no labor)	90 Days (no labor)

Special Extensions

The chart below details special extensions to this warranty:

Warranty Code	Warranty Exception	Warranty Period	Use	Detail
SB	Batteries for AMP [™] Sno-Thro [®]	2 Years	Consumer	100% first year; prorated second year.

Exceptions and Limitations

The chart below details special exceptions to this warranty:

Warranty Code	Warranty Exception	Warranty Period	Use	Detail
All	Batteries	1 Year	All	Prorated
All	Belts, Muffler, Tires	None	Commercial	These components are not covered when used commercially.
All	Cloth, Plastic, and Rubber Components (Including Belts and Cables)	Maximum 2 Years	All	Warranty is limited to 2 years for consumer use. (1 year for warranty code "PD".) Except as noted above, these components are covered for defect, not for wear.
SA, SB, SC	Idlers	Maximum 2 Years	All	Warranty is limited on idlers to 2 years for consumer use.
All	Engines	See Engine Manufacturer's Warranty	All	Engines are covered by engine manufacturer's warranty. Refer to engine manufacturer's warranty statement.

Customer Responsibilities

Register the product immediately at the time of sale. If the dealer does not register the product, the customer must complete the product registration card in the literature package and return it to the Ariens Company, or register the unit online at www.ariens.com, www.gravelly.com, www.countax.com, www.parkersweeper.com.

To obtain warranty service, the **original purchaser** must:

- Perform the maintenance and adjustments explained in the owner's manual.
- Promptly notify Ariens or an authorized Ariens, Gravelly, Parker or Countax service representative of the need for warranty service.
- Transport the product to and from the place of warranty service at owner's expense.
- Have the warranty service performed by an authorized Ariens, Gravelly, Parker or Countax service representative.

To Find an Authorized Service Representative:

In the U.S. and Canada:		
Use the dealer locator on our websites: www.ariens.com • www.gravelly.com		
Or contact us by mail or by phone:		
In the U.S., Canada, Mexico, Caribbean, Central and South America:	In Europe, Asia, Africa or the Middle East:	In Australia or New Zealand:
Ariens Company 655 W. Ryan Street Brillion, WI 54110 Phone: (920) 756 - 4688 www.ariens.com	Countax Ltd, Countax House Great Haseley, Oxfordshire, OX44 7PF Phone: 0800 597 7777 www.countax.com	109-111 Abbot House Hallam, Victoria 3803 Australia Phone: (03) 9796 4244 1800 335 489 www.bynorm.com.au

Exclusions - Items Not Covered by This Warranty

- Parts that are not genuine Ariens, Gravelly, Parker or Countax service parts are not covered by this warranty and may void the warranty.
- Damages resulting from the installation or use of any part, accessory, or attachment which is not approved by the Ariens Company for use with product(s) identified herein are not covered by this warranty.
- The following maintenance, service and replacement items are not covered by this warranty unless they are noted in the Limitations section above: lubricants, spark plugs, oil, oil filters, air filters, fuel filters, brake linings, brake arms, brake shoes, skid shoes, scraper blades, shear bolts, mower blades, mower vanes, brushes, headlights, light bulbs, knives, cutters.
- Any misuse, alteration, improper assembly, improper adjustment, neglect, or accident which requires repair is not covered by this warranty.
- **Use of gasoline blends exceeding 10% ethanol voids any and all warranties.**
- Products are designed to the specifications in the area that the product was originally distributed. Different areas may have significantly different legal and design requirements. This warranty is limited to the requirements in the area in which the unit was originally distributed. Ariens Company does not warrant this product to the requirements of any other area. Warranty service is limited to service within the area originally distributed.
- In countries other than the United States and Canada, contact the Ariens Company dealer for warranty policies that govern within your country. Rights may vary from country to country and within any one country.

Special Exclusions on Utility Vehicles

The following uses void the warranty terms on Utility Vehicles (Warranty Code UA):

- Renting or leasing the utility vehicle.
- Using the utility vehicle to tow or carry loads in excess of the limits specified in the owner/operator manual.
- Modifying the utility vehicle with parts and accessories that are not genuine or authorized Ariens or Gravelly parts or accessories.
- Modifying the utility vehicle without express written authorization from the Ariens Company.
- Operating the utility vehicle when it has not been completely and properly assembled and pre-delivered by an authorized Gravelly dealer.

Disclaimer

Ariens Company may from time to time change the design of its products. Nothing contained in this warranty shall be construed as obligating the Ariens Company to incorporate such design changes into previously manufactured products, nor shall such changes be construed as an admission that previous designs were defective.

LIMITATION OF REMEDY AND DAMAGES

Ariens Company's liability under this warranty, and under any implied warranty that may exist, is limited to repair of any defect in workmanship, and repair or replacement of any defective part. Ariens Company shall not be liable for incidental, special, or consequential damages (including lost profits). Some states do not allow the exclusion of incidental or consequential damages, so the above limitation or exclusion may not apply to you.

DISCLAIMER OF FURTHER WARRANTY

Ariens Company makes no warranty, express or implied, other than what is expressly made in this warranty. If the law of your state provides that an implied warranty of merchantability, or an implied warranty of fitness for particular purpose, or any other implied warranty, applies to Ariens Company, then any such implied warranty is limited to the duration of this warranty. Some states do not allow limitations on how long an implied warranty lasts, so the above limitation may not apply to you.

This warranty gives you specific legal rights, and you may also have other rights which vary from region to region.



THE KING OF SNOW®

Ariens Company
655 West Ryan Street
Brillion, WI 54110-1072
920-756-2141
Fax 920-756-2407
www.ariens.eu

See your local dealer for these useful accessories:



Sno-Thro® Cover
Protect your investment. Available
in two sizes.



Drift Cutter Kit
Helps your Sno-Thro® tackle
drifting and packed snow.



Protective Floor Mat
Protects floor from rust, dirt and
snow melt.

Non-abrasive Skid Shoes
Protect decorative surfaces from
scratching and marring.



Please see your local dealer for accessory fit up and installation.
Visit www.ariens.com for more information on all of our great accessories.

An *Ariens* Company Brand