



# Sno-Tek™

## Owner/Operator Manual

## Manuel Du Propriétaire/Utilisateur

---

### Models

920400 – Sno-Tek 24

920401 – Sno-Tek 26

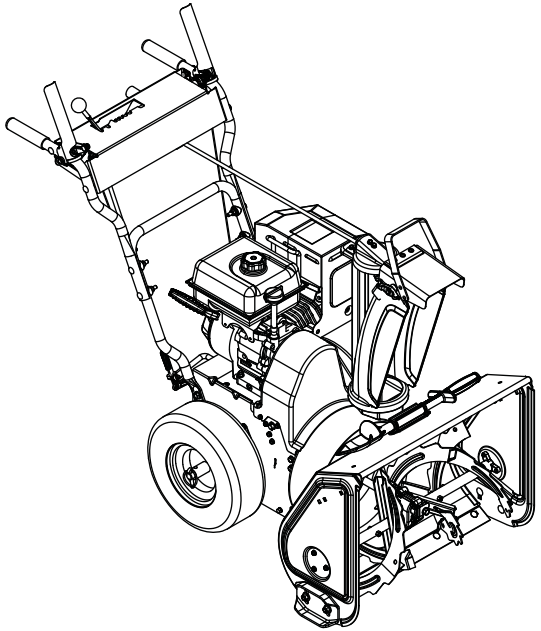

GB

ENGLISH

F

FRANÇAIS

03883300A 8/09  
Printed in USA

# TABLE OF CONTENTS

SAFETY .....	4	STORAGE .....	27
ASSEMBLY .....	8	SERVICE PARTS .....	27
CONTROLS and FEATURES .....	11	ACCESSORIES .....	27
OPERATION .....	12	TROUBLESHOOTING .....	28
MAINTENANCE .....	16	SPECIFICATIONS .....	29
SERVICE AND ADJUSTMENTS .....	18	WARRANTY .....	30

## INTRODUCTION

### NON-ENGLISH MANUALS

Manuals in languages other than English may be obtained from your dealer. Visit your dealer or [www.ariens.com](http://www.ariens.com) for a list of languages available for your equipment.

Manuals printed in languages other than English are also available as a free download on our website:

<http://www.ariens.com>

### MANUALES EN IDIOMAS DIFERENTES DEL INGLES

Puede obtener manuales en idiomas diferentes del inglés en su distribuidor. Visite a su distribuidor o vaya a [www.ariens.com](http://www.ariens.com) para obtener una lista de idiomas disponibles para su equipo.

También puede imprimir manuales en idiomas diferentes del inglés descargándolos gratuitamente de nuestra página Web:

<http://www.ariens.com>

### MANUELS NON ANGLAIS

Des manuels dans différentes langues sont disponibles chez votre revendeur. Rendez-vous chez votre revendeur ou allez sur le site [www.ariens.com](http://www.ariens.com) pour consulter la liste des langues disponibles pour votre équipement.

Les manuels imprimés dans des langues différentes de l'anglais sont également disponibles en téléchargement gratuit sur notre site Web :

<http://www.ariens.com>

### MANUALS

Before operation of unit, carefully and completely read your manuals. If used improperly, this unit could be dangerous and cause personal injury or property damage. The contents will provide you with safety instructions for the safe use of your unit during normal operation and maintenance.

All reference to left, right, front, or rear are given from operator standing in operation position and facing the direction of forward travel.

### ENGINE MANUAL

The engine on this unit is covered by a separate manual specific to the engine. This manual is included in the literature package that shipped with the unit. Refer to this manual for engine service recommendations. If the engine manual is not available, contact the engine manufacturer for a replacement manual.

### MODEL AND SERIAL NUMBERS

When ordering replacement parts or making service inquiries, know the Model and Serial numbers of your unit and engine.

Numbers are located on the product registration form in the unit literature package. They are printed on a serial number label, located on the frame of your unit.

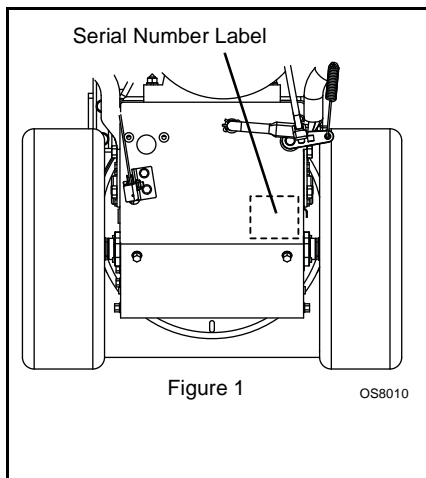

- Record unit model and serial numbers here.

- Record engine model and serial numbers here.

## PRODUCT REGISTRATION

The Ariens dealer must register the product at the time of purchase. Registering the product will help the company process warranty claims or contact you with the latest service information. All claims meeting requirements during the limited warranty period will be honored, whether or not the product registration card is returned. Keep a proof of purchase if you do not register your unit.

**Customer Note:** If the dealer does not register your product, please fill out, sign, and return the product registration card to Ariens or go to [www.ariens.com](http://www.ariens.com).

## UNAUTHORIZED REPLACEMENT PARTS

Use only Ariens replacement parts. The replacement of any part on this vehicle with anything other than an Ariens authorized replacement part may adversely affect the performance, durability, or safety of this unit and may void the warranty. Ariens disclaims liability for any claims or damages, whether warranty, property damage, personal injury or death arising out of the use of unauthorized replacement parts. To locate your nearest Ariens dealer, go to [www.ariens.com](http://www.ariens.com) on the internet.

## DISCLAIMER

Ariens reserves the right to discontinue, make changes to, and add improvements upon its products at any time without public notice or obligation. The descriptions and specifications contained in this manual were in effect at printing. Equipment described within this manual may be optional. Some illustrations may not be applicable to your unit.

## DELIVERY

**Customer Note:** If you have purchased this product without complete assembly and instruction by your retailer, it is your responsibility to:

1. Read and understand all assembly instructions in this manual. If you do not understand or have difficulty following the instructions, contact your nearest Ariens dealer for assistance. Make sure all assembly has been properly completed.

**NOTE:** To locate your nearest Ariens dealer, go to [www.ariens.com](http://www.ariens.com) on the Internet.



**WARNING:** Improper assembly or adjustments can cause serious injury.

2. Understand all safety precautions provided in the manuals.
3. Review control functions and operation of the unit. Do not operate the unit unless all controls function as described in this manual.
4. Review recommended lubrication, maintenance and adjustments.
5. Review limited warranty policy.
6. Fill out a product registration card and return the card to the Ariens Company or go to [www.ariens.com](http://www.ariens.com).

# SAFETY



**WARNING:** To avoid injury to hands and feet, always disengage clutches, shut off engine, and wait for all movement to stop before unblocking or working on snow thrower.

Hand contact with the rotating impeller is the most common cause of injury associated with snow throwers. Never use your hand to clean out the discharge chute.

Keep hands and feet away from auger and impeller.

## SAFETY ALERTS



Look for these symbols to point out important safety precautions. They mean:

**Attention!**



**Personal Safety Is Involved!**

**Become Alert!**

**Obey The Message!**

The safety alert symbols above and signal words below are used on decals and in this manual. Read and understand all safety messages.



**DANGER: IMMINENTLY HAZARDOUS SITUATION!** If not avoided, **WILL RESULT** in death or serious injury.



**WARNING: POTENTIALLY HAZARDOUS SITUATION!** If not avoided, **COULD RESULT** in death or serious injury.



**CAUTION: POTENTIALLY HAZARDOUS SITUATION!** If not avoided, **MAY RESULT** in minor or moderate injury. It may also be used to alert against unsafe practices.

## NOTATIONS

**NOTE:** General reference information for proper operation and maintenance practices.

**IMPORTANT:** Specific procedures or information required to prevent damage to unit or attachment.

## PRACTICES AND LAWS

Practice usual and customary safe working precautions, for the benefit of yourself and others. Understand and follow all safety messages. Be alert to unsafe conditions and the possibility of minor, moderate, or serious injury or death. Learn applicable rules and laws in your area. Always follow the practices set forth in this manual.

## REQUIRED OPERATOR TRAINING

Original purchaser of this unit was instructed by the seller on safe and proper operation. If unit is to be used by someone other than original purchaser; loaned, rented or sold, **ALWAYS** provide this manual and any needed safety training before operation.

## SAFETY DECALS AND LOCATIONS

**ALWAYS** replace missing or damaged safety decals. Refer to figure below for safety decal locations.

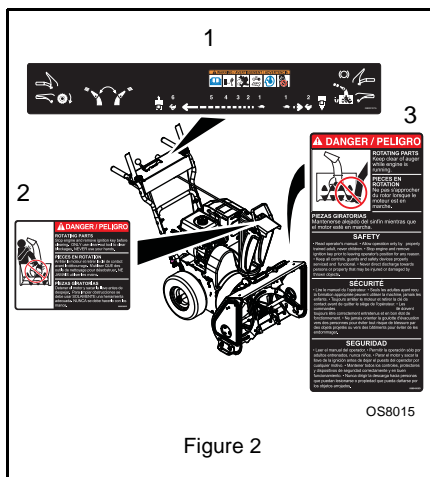

## 1. WARNING!



OL1801

Read Owner/Operator Manual.



OL4370

Keep people away from unit while operating. Keep children out of work area and under watchful care of a responsible adult.



OL0910

Never direct discharge towards persons or property that may be injured or damaged by thrown objects.



OL4010

Stop engine, remove key, read manual before making any repairs or adjustments.



OL4690

Wear appropriate hearing protection.



ONLY use clean-out tool to clear blockages. NEVER use your hands.

## 2. DANGER!



OS6610

ROTATING PARTS! ONLY use clean-out tool to clear blockages. NEVER use your hands. **High speed impeller rotates below discharge opening. Wait for all moving parts to stop before removing clogs or servicing.**

## 3. DANGER!



OS2080

ROTATING PARTS. Keep clear of auger while engine is running.

- Read Operator's Manual.
- Allow operation only by properly trained adult, never children.
- Stop engine and remove ignition key prior to leaving the operator's position for any reason.
- Keep all controls, guards and safety devices properly serviced and functional.
- Never direct discharge towards persons or property that may be injured or damaged by thrown objects.

## SAFETY RULES

Read, understand, and follow all safety practices in owner/operator manual before beginning assembly or operating. Failure to follow instructions could result in personal injury and/or damage to unit.

ALWAYS remove key and/or wire from spark plug before assembly, maintenance or service. Unintentional engine start up can cause death or serious injury.

Complete a walk around inspection of unit and work area to understand:

- Work area
- Your unit
- All safety decals

ALWAYS check overhead and side clearances carefully before operation.

ALWAYS be aware of traffic when operating along streets or curbs.

Keep children and people away. Keep children out of work area and under watchful care of a responsible adult.

NEVER allow children to operate or play on or near unit. Be alert and shut off unit if children enter area.

DO NOT allow adults to operate unit without proper training. Only trained adults may operate unit. Training includes actual operation.

Keep area of operation clear of all toys, pets, and debris. Thrown objects can cause injury.

Check for weak spots on docks, ramps or floors. Avoid uneven work areas and rough terrain. Stay alert for hidden hazards.

DO NOT operate near drop-offs, ditches, or embankments. Unit can suddenly turn over if a wheel is over the edge of a cliff or ditch, or if an edge caves in.

Falling snow, fog, etc. can reduce vision and cause an accident. Operate unit only when there is good visibility and light.

NEVER operate unit after or during the use of medication, drugs or alcohol. Safe operation requires your complete and unimpaired attention at all times.

NEVER allow anyone to operate this unit when their alertness or coordination is impaired.

DO NOT operate unit without wearing adequate winter outer garments. Wear adequate safety gear, including safety glasses with side shields, and protective gloves. Wear proper footwear to improve footing on slippery surfaces.

DO NOT wear loose clothing or jewelry and tie back hair that may get caught in rotating parts.

Protect eyes, face and head from objects that may be thrown from unit. Wear appropriate hearing protection.

Avoid sharp edges. Sharp edges can cut. Moving parts can cut off fingers or a hand.

ALWAYS keep hands and feet away from all rotating parts during operation. Rotating parts can cut off body parts.

NEVER place your hands or any part of your body or clothing inside or near any moving part while unit is running.

ALWAYS keep hands away from all pinch points.

DO NOT touch unit parts which might be hot from operation. Allow parts to cool before attempting to maintain, adjust or service.

Never direct discharge towards persons or property that may be injured or damaged by thrown objects. Use extreme caution on gravel surfaces. Stay alert for hidden hazards or traffic. Adjust skid shoes so scraper blade does not contact gravel.

DO NOT throw snow any higher than necessary.

Deflected materials can cause injury and property damage.

Always stand clear of the discharge area when operating this unit.

Fumes from engine exhaust can cause injury or death. DO NOT run engine in an enclosed area. Always provide good ventilation.

ALWAYS disengage attachment, stop unit and engine, remove key and allow moving parts to stop before leaving operator's position.

ROTATING IMPELLER CAN CAUSE SERIOUS INJURY. NEVER ATTEMPT TO UNCLOG OR CLEAN UNIT WHILE ENGINE IS RUNNING.

Read, understand, and follow all instructions in the manual and on the machine before starting.

Understand:

How to operate all controls.

The functions of all controls.

How to STOP in an emergency.

Before starting engine, disengage control(s).

ALWAYS allow unit and engine to adjust to outdoor temperatures before clearing snow.

Always be sure of your footing, especially when operating in reverse or leaving the operator's position. Walk, never run during operation.

DO NOT overload the machine capacity by attempting to operate or to clear snow at too fast a rate.

Slow down and turn corners slowly.

Do not operate in reverse unless absolutely necessary. ALWAYS back up slowly. Always look down and behind before and while backing.

Disengage attachment drive when traveling from one work area to another.

Abnormal vibrations are a warning of trouble.

Striking a foreign object can damage unit. Immediately stop unit and engine. Remove key and wait for all moving parts to stop.

Remove wire from spark plug. Inspect unit and make any necessary repairs before restart.

Before cleaning, removing clogs or making any inspections, repairs, etc.: disengage clutch(es), stop unit and engine, remove key, allow moving parts to stop. Allow hot parts to cool.

Run unit a few minutes after clearing snow to prevent freeze-up of attachment.

Disengage attachment when not in use.

Disengage all clutches before starting engine. Adjust skid shoes to clear gravel or crushed rock surfaces safely.

Never leave a running unit unattended.

ALWAYS shut off engine before leaving unit. ALWAYS remove key to prevent unauthorized use.

Never carry passengers.

Check clutch and brake operation frequently. Adjust and service as required. All motion of drive wheels and auger/impeller must stop quickly when control levers are released.

DO NOT operate on steep slopes. DO NOT clear snow across the face of slopes. Keep all movement on slopes slow and gradual. DO NOT make sudden changes in speed or direction. Use a slow speed to avoid stops or shifts on slopes. Avoid starting or stopping on a slope.

DO NOT park unit on a slope unless absolutely necessary. When parking on a slope always block the wheels.

ALWAYS shut off engine, remove key, and close fuel shut-off valve or drain fuel when transporting unit on a truck or trailer.

Use extra care when loading or unloading unit onto trailer or truck.

Secure unit chassis to transport vehicle.

NEVER secure from rods or linkages that could be damaged.

DO NOT transport machine while engine is running.

Keep unit free of ice or other debris. Clean up oil or fuel spills.

This product is equipped with an internal combustion type engine. DO NOT use unit on or near any unimproved, forest-covered or brush covered land unless exhaust system is equipped with a spark arrester meeting applicable local, state or federal laws. A spark arrester, if it is used, must be maintained in effective working order by operator.

Fuel is highly flammable and its vapors are explosive. Handle with care. Use an approved fuel container.

NO smoking, NO sparks, NO flames.

ALWAYS allow engine to cool before servicing.

NEVER fill fuel tank when engine is running or hot from operation.

NEVER fill or drain fuel tank indoors.

Replace fuel cap securely and clean up spilled fuel.

Never fill containers inside a vehicle or on a truck or trailer bed with a plastic liner. Always place containers on the ground away from your vehicle before filling.

When practical, remove gas-powered equipment from the truck or trailer and refuel it on the ground. If this is not possible, then refuel such equipment on a trailer with a portable container, rather than from a gasoline dispenser nozzle.

Keep the nozzle in contact with the rim of the fuel tank or container opening at all times until fueling is complete. Do not use a nozzle lock-open device.

If fuel is spilled on clothing, change clothing immediately.

Before tipping unit up onto housing, remove fuel so no spills will occur. Ensure unit is secure and will not tip over during maintenance.

ALWAYS keep protective structures, guards, and panels in good repair, in place and securely fastened. NEVER modify or remove safety devices.

DO NOT change engine governor settings or over-speed engine.

Fumes from engine exhaust can cause injury or death. DO NOT run engine in an enclosed area. Always provide good ventilation.

ALWAYS maintain unit in safe operating condition. Damaged or worn out muffler can cause fire or explosion.

Keep all hardware properly tightened. Check shear bolts frequently.

Maintain or replace safety and instruction labels, as necessary.

NEVER store unit with fuel in fuel tank, inside a building where any ignition sources are present such as hot water heaters, space heaters, or clothes dryers. Allow the engine to cool before storing in any enclosure.

Shut off fuel and allow engine to cool completely before storing in closed area or covering unit.

For extended storage, clean unit thoroughly. See engine manual for proper storage.

Use only attachments or accessories designed for your unit.

Check components frequently. If worn or damaged, replace with manufacturer's recommended parts.

# ASSEMBLY



**WARNING: AVOID INJURY.** Read and understand the entire *Safety* section before proceeding.



**WARNING:** Dropping or tipping over boxed unit could result in personal injury or damage to unit.

## PACKAGE CONTENTS

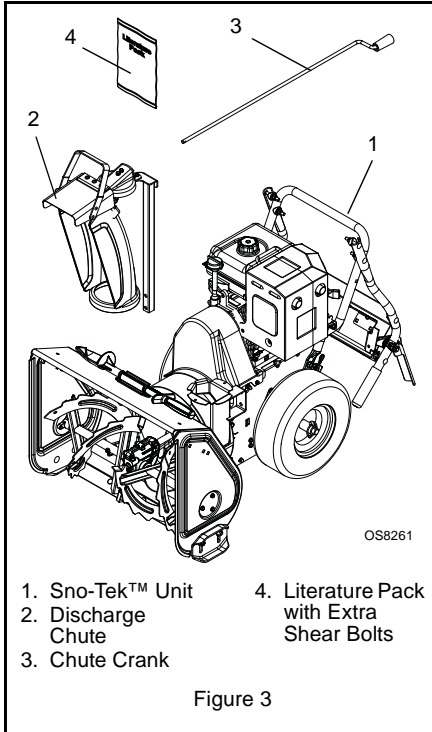

## Unfold Handlebar (Figure 4)

1. Remove the lower and loosen the upper hardware on the handlebar assembly.
2. Loosen the hardware on the shift rod.
3. Put the speed selector lever in the sixth forward position.
4. Rotate the handlebars into operating position.

**NOTE:** Be careful not to damage cable spring hooks when rotating handlebars upward.

5. Install and tighten the hardware on the handlebar assembly and shift rod.

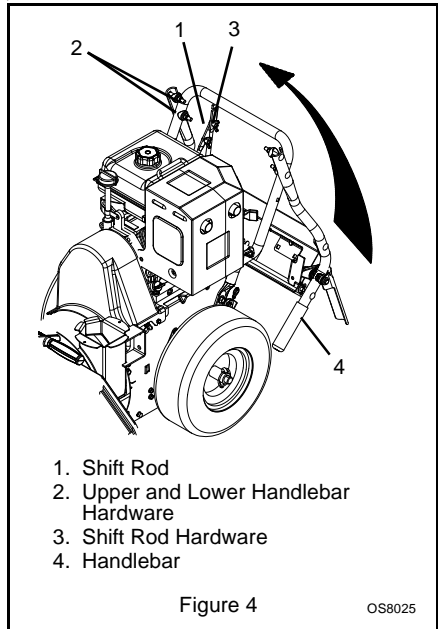

## ASSEMBLY

### Tools Required:

- Pliers
- Open-end wrenches: 3/8, 7/16, 1/2, 9/16 in. and/or adjustable wrench
- Tire gauge



### Install Discharge Chute (Figure 5)

1. Remove mounting hardware from the bottom of the chute pedestal.
2. Install discharge chute over opening in the auger housing and secure pedestal to auger housing with hardware removed in step 1.

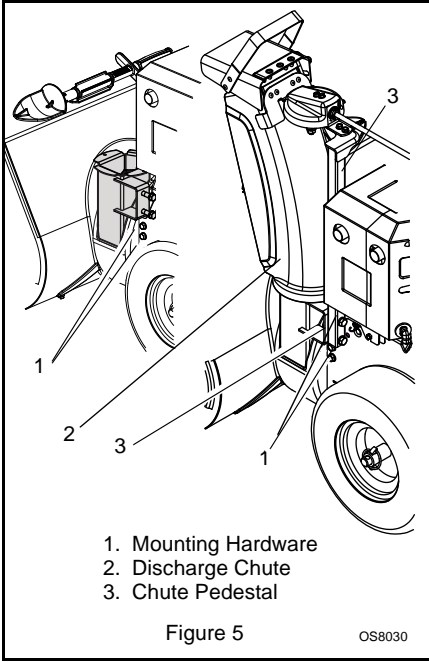

### Install Discharge Chute Crank (Figure 6)

1. Slide chute crank through the support bracket.
2. Connect the chute crank to the pinion gear on chute with spring clip pin.

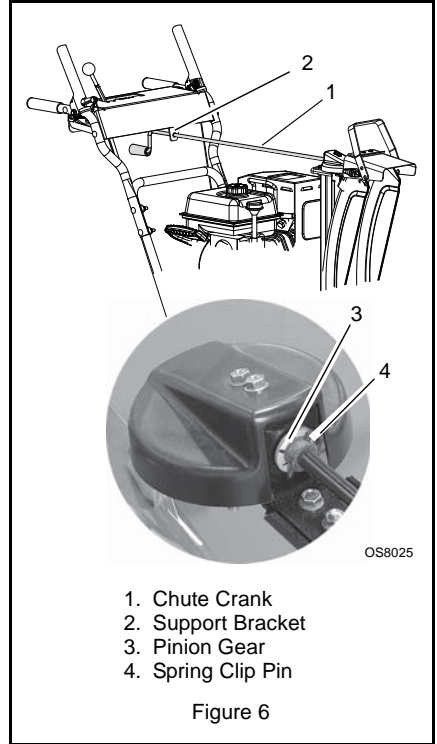

## Check Function of Dual Handle Interlock

Without the engine running, press down (engage) both clutch levers. Release attachment clutch lever. Attachment clutch should remain engaged until traction clutch lever is released, then both clutches *must* disengage. If they do not, contact your dealer for repairs.

## Check Tire Pressure

Check tire pressure and adjust to the pressure listed on tire sidewall.



**CAUTION:** Avoid injury! Explosive separation of tire and rim parts is possible when they are serviced incorrectly:

- Do not attempt to mount a tire without the proper equipment and experience to perform the job.
- Do not inflate the tires above the recommended pressure.
- Do not weld or heat a wheel and tire assembly. Heat can cause an increase in air pressure resulting in an explosion. Welding can structurally weaken or deform the wheel.
- Do not stand in front or over the tire assembly when inflating. Use a clip-on chuck and extension hose long enough to allow you to stand to one side.

## Check Auger Gearcase Oil

Check oil level in auger gearcase (see *Check Auger Gearcase* on page 17).

## Check Engine Crankcase Oil

**IMPORTANT:** The engine is shipped with 5W-30 oil in crankcase. Refer to engine manual for detailed instructions.

## Fill Engine Fuel Tank

Refer to engine manual for proper fuel type and tank capacity.

## Check Function of all Controls

Ensure unit runs and performs properly. Refer to *Operation*.

## Run-in Attachment Belt

1. Start unit in a well-ventilated area according to *Starting and Shut Off* on page 15.
2. Engage attachment clutch lever and run attachment for about 15 minutes.
3. Stop unit, wait for all moving parts to stop, and remove spark plug wire.
4. Adjust belt finger, if necessary. See *Attachment Drive Belt Replacement* on page 20.
5. Adjust clutch idler according to *Attachment Clutch/Brake Adjustment* on page 23.

## CONTROLS AND FEATURES

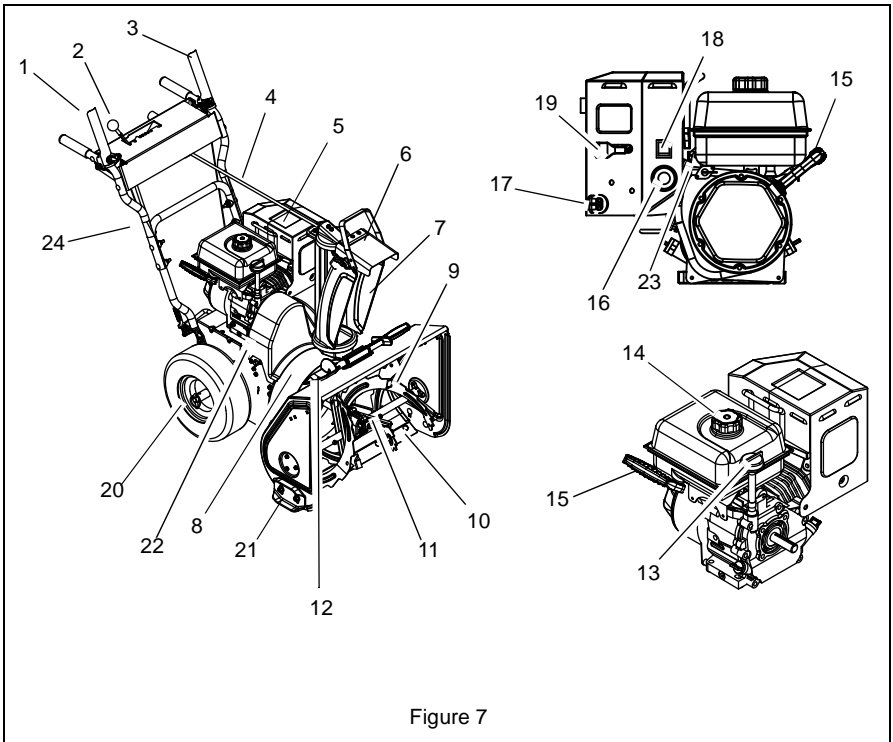

Figure 7

- |                                |                                  |
|--------------------------------|----------------------------------|
| 1. Attachment Clutch Lever     | 14. Gas Tank and Cap             |
| 2. Speed Selector              | 15. Recoil Starter Handle        |
| 3. Traction Drive Clutch Lever | 16. Primer Bulb                  |
| 4. Chute Crank                 | 17. Ignition Switch (Push /Pull) |
| 5. Muffler Guard               | 18. Engine Shutoff Switch        |
| 6. Discharge Chute Deflector   | 19. Choke                        |
| 7. Discharge Chute             | 20. Axle Lock Pin                |
| 8. Impeller                    | 21. Skid Shoe(s)                 |
| 9. Auger                       | 22. Belt Cover                   |
| 10. Scraper Blade              | 23. Fuel Shut-off Valve          |
| 11. Auger Gearcase             | 24. Handlebar                    |
| 12. Clean-out Tool             |                                  |
| 13. Oil Fill and Dipstick      |                                  |

# OPERATION



**WARNING: AVOID INJURY.** Read and understand the entire *Safety* section before proceeding.



**WARNING:** To avoid injury to hands and feet, always disengage clutches, shut off engine, and wait for all movement to stop before unclogging or working on snow thrower. Keep hands and feet away from auger and impeller.

## CONTROLS AND FEATURES

See Figure 7 for all Controls and Features locations.

### Dual Handle Interlock

When attachment clutch and then traction drive clutch are engaged, the attachment clutch will remain engaged (lever down) if released. To stop attachment, release traction drive clutch and both clutches will disengage.

### Traction Drive Clutch - Left Hand Lever

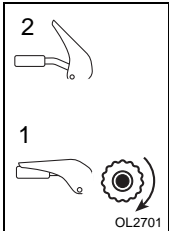

Squeeze the traction drive clutch lever against the handlebar (1) to engage wheel drive for propelling unit. Forward speed will vary according to snow depth and moisture content.

Release lever (2) to stop movement.

**NOTE:** When traveling to or from the area to be cleared, press down on the handlebars enough to raise the front of the unit slightly off the surface. Engage the traction drive clutch without engaging the attachment drive clutch.

### Attachment Clutch - Right Hand Lever

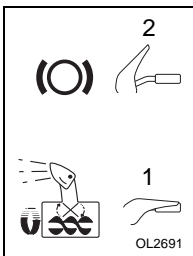

Squeeze attachment clutch lever against handlebar (1) to engage attachment. Release both clutch levers (2) to disengage power and apply brake to attachment.

**IMPORTANT:** If the belt squeals when the attachment clutch lever is engaged, the impeller may be frozen in the auger housing. Immediately release the attachment clutch lever and move the unit into a heated area to thaw.

**NOTE:** If belt squeals when impeller turns freely, see *Attachment Drive Belt Replacement* on page 20.

### Ignition Switch (Push/Pull Safety Key)

Key Switch has two positions:

1. "Stop" - pulled out
2. "Run" - pushed in

**NOTE:** DO NOT twist key after it is inserted.

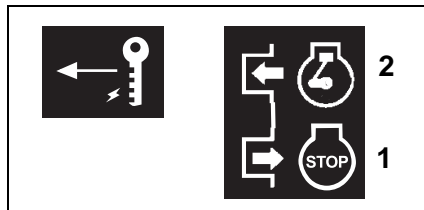

### Engine Shutoff Switch

1. Set the engine shutoff switch to the run position ("Run") to start and operate the engine.
2. Set the engine shutoff switch to the stop position ("Stop") to shut off a running engine.

### Primer Bulb

Pushing the primer bulb in adds fuel for easier engine start. Refer to *Starting and Shut Off* on page 15.



### Speed Selector

Position the speed selector in the appropriate speed notch to control forward and reverse travel.

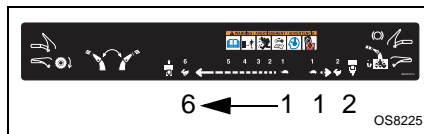

Forward:



- (6) Fastest
- (1) Slowest

Reverse:



- (1) Slow
- (2) Fast

**IMPORTANT:** DO NOT change motion from forward to reverse with clutch engaged. Forward speed can be changed without declutching.

### Fuel Shut-Off Valve

**IMPORTANT:** The fuel shut-off valve **MUST** be in the closed position prior to transporting the unit.

The fuel shut-off valve has two positions:

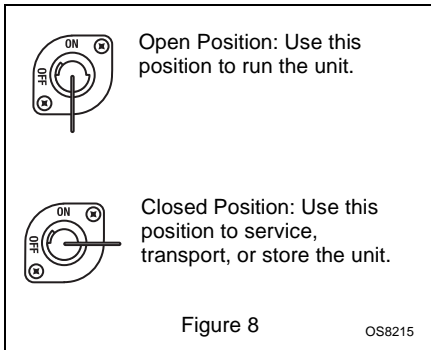

### Choke Control

1. Choke Closed position: chokes off air to engine for easier start.
2. Choke Open position: allows for normal operation.

**IMPORTANT:** Gradually open choke after engine starts.



### Recoil Starter Handle

When pulled, handle will turn engine over.

**IMPORTANT:** DO NOT let handle snap back against starter.

See *Starting and Shut Off* on page 15.

### Snow Clean-Out Tool (Figure 9)



**WARNING:** Hand contact with the rotating impeller is the most common cause of injury associated with snow throwers. Never use your hand to clean out the discharge chute.

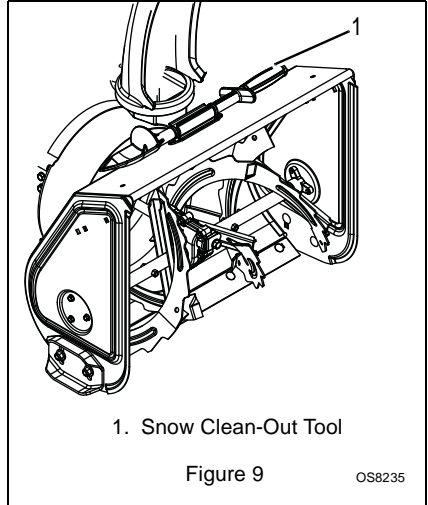

To clear the discharge chute:

1. Shut off the engine.
2. Wait 10 seconds and make sure impeller blades have stopped rotating.
3. Remove the snow clean-out tool (1) from the auger housing and use it to remove the clog from the discharge chute.
4. Replace the snow clean-out tool on the auger housing.

### Discharge Chute Deflector

**ALWAYS** position discharge chute deflector at a safe angle before starting engine.

**DO NOT** throw snow any higher than necessary.

Push deflector handle forward or down to throw snow lower. Pull deflector handle up or to the rear to throw snow higher.

**IMPORTANT:** If chute deflector does not stay in set position, adjust as directed in *SERVICE AND ADJUSTMENTS* on page 18, or repair before operation.

### Discharge Chute

Discharge chute rotates 205°.

**ALWAYS** position discharge chute in safe direction and angle, away from operator and bystanders, before starting engine.

## Discharge Chute Crank

**IMPORTANT:** If chute does not stay in set position, adjust as directed in *SERVICE AND ADJUSTMENTS* on page 18, or repair before operation.

Rotate the chute with the discharge chute crank handle.

**IMPORTANT:** DO NOT force frozen chute controls. If frozen, take to warm place until controls are free.

## Axle Lock Pin (Figure 10)

Use the axle lock pin to lock or unlock the right or left wheel. Lock both wheels to increase traction; unlock one wheel to allow for easier turning of the unit.

**NOTE:** Unit will not drive with both wheels unlocked.

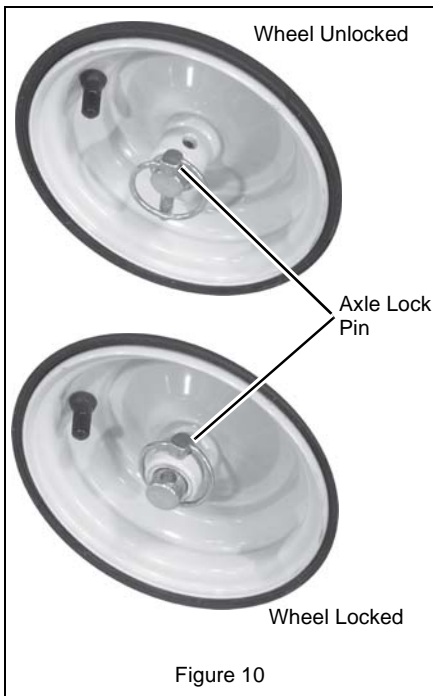

## Scraper Blade

The scraper blade allows better contact with the surface being cleared. It also prevents damage to the housing from wear.

**IMPORTANT:** DO NOT allow scraper blade to wear too far or auger/impeller housing will become damaged.

## Skid Shoes

The skid shoes control the distance between the scraper blade and the ground. Adjust skid shoes equally to keep blade level with the ground. Refer to *Pre-Start* on page 15 for recommended settings.

## FILLING FUEL TANK



**WARNING: AVOID INJURY.** Read and understand the entire *Safety* section before proceeding.

## GASOLINE

### Fuel Recommendations

Use unleaded gasoline with a pump octane rating of 86 or higher. These engines operate best on unleaded gasoline.



**CAUTION:** Do NOT use stale or contaminated gasoline or an oil/gasoline mixture. Avoid getting dirt or water in the fuel tank. Use only proper fuel containers that are properly marked.



**CAUTION:** DO NOT use E85 blended fuels. This engine is not E20/E30/E85 compatible.

Maximum recommended ethanol content: 10%

### Adding a Fuel Stabilizer to Extend Fuel Storage Life

**NOTE:** Fuel stabilizer is recommended for long term storage.

1. Turn the fuel valve off while engine is running and allow the engine to run until it stops. Turn engine OFF when it begins surging to avoid engine damage.
2. Add fuel stabilizer, following the manufacturer's instructions.
3. Turn fuel valve on after adding fuel stabilizer.
4. Re-start engine.
5. Run the engine outdoors for 1 minute to be sure that treated gasoline has replaced the untreated gasoline in the carburetor.
6. Slow the engine to an idle speed.
7. Repeat step 1 above.

### To add fuel to fuel tank:

1. ALWAYS place unit in open or well-ventilated area.
2. Stop engine and allow to cool.

- Clean fuel cap and surrounding area to prevent dirt from entering fuel tank.
- Remove cap.

**IMPORTANT:** See engine manual for correct type and grade of fuel.

- Fill fuel tank to indicator line in filler neck with unleaded gasoline.
- Replace fuel cap and tighten.
- ALWAYS clean up any spilled fuel.

## PRE-START

### 1. Frozen Impeller

**IMPORTANT:** Before starting engine, check impeller to be sure it is not frozen.

To check impeller:

- With ignition key switch in "Stop" position, squeeze attachment clutch lever to engaged position.
- Pull recoil starter handle.
- If impeller is frozen, (cannot pull starter handle) move unit to a heated area and thaw to prevent possible damage.

### 2. Check Function of Clutches

If clutches do not engage or disengage properly, adjust or repair before operation. See *Attachment Clutch/Brake Adjustment* on page 23 and *Traction Drive Clutch Adjustment* on page 25.

### 3. Check Dual Handle Interlock

Without the engine running, press down (engage) both clutch levers. Release attachment clutch lever. Attachment clutch should remain engaged until traction clutch lever is released, then both clutches *must* disengage.

If clutches do not engage or disengage properly, adjust or repair before operation (see *Attachment Clutch/Brake Adjustment* on page 23 and *Traction Drive Clutch Adjustment* on page 25).

### 4. Check Axle Lock Pins

Use the axle lock pins to lock or unlock the wheels. Lock both wheels to increase traction; unlock one wheel to allow for easier turning of the unit.

### 5. Check Skid Shoes

Check and adjust skid shoes (*Skid Shoes* on page 18). Allow 1/8 in. (3 mm) between scraper blade and hard, smooth surface(s). Allow 1-1/4 in. (30 mm) between scraper blade and uneven or gravel surfaces.

## 6. Check Engine Fuel & Crankcase Oil



**WARNING:** AVOID INJURY. Read and understand the entire *Safety* section before proceeding.

Check and add fuel if required. Check that the engine crankcase oil is full using dipstick. Refer to engine manual for detailed instructions.

## TO STOP IN AN EMERGENCY

Immediately release both control levers to stop unit in an emergency. Stop engine, remove key and wait for all rotating parts to stop before leaving operator's position.

## STARTING AND SHUT OFF



**WARNING:** FAILURE TO FOLLOW INSTRUCTIONS could result in personal injury and/or damage to unit. DO NOT attempt to start your unit at this time. Read entire owner/operator manual and the engine manual first.

**IMPORTANT:** Allow unit and engine to adjust to the outdoor temperature before clearing snow. Before shut-off, run the attachment a few minutes to prevent impeller freeze-up.

**NOTE:** Try out each control without the engine running to see how it works and what it does.

### Manual Start

- Turn discharge chute straight ahead.
- Make sure that the traction clutch and attachment drive clutch levers are fully disengaged.
- Push primer bulb 2 or 3 times for cold engine.

**NOTE:** When temperature is below -15° F (-26° C) additional priming may be needed.

- If engine is cold, apply choke. See engine manual for detailed instructions.

**NOTE:** A warm engine requires less choking than a cold engine.

- Insert key into ignition switch and push into RUN position. DO NOT twist key after it is inserted.
- Turn on the engine shutoff switch ("Run").
- Grasp starter handle and pull rope out slowly until it pulls harder. Let rope rewind slowly.
- Pull rope with a rapid continuous full arm stroke. Let rope rewind slowly.

**IMPORTANT:** DO NOT let starter handle snap against starter.

9. Repeat steps 7 and 8 until engine starts. (If engine does not start, refer to **TROUBLESHOOTING** on page 28.)
10. Adjust choke as needed.

### Shut Off

1. Release traction drive clutch lever and allow unit to come to a complete stop.
2. Run impeller a few minutes after use to prevent freeze-up of impeller.
3. Release attachment clutch lever and wait for all moving parts to come to a complete stop.
4. Turn off the engine shutoff switch ("Stop").
5. Remove key.

## SNOW REMOVAL

**IMPORTANT:** Allow unit and engine to adjust to the outdoor temperature before clearing snow.

**NOTE:** Attachment clutch should be engaged before wheel drive clutch when throwing snow.

1. Select speed control position and direction.
2. Engage attachment clutch - right hand lever.
3. Engage traction drive clutch - left hand lever.

**IMPORTANT:** DO NOT overload unit capacity by attempting to clear snow at too fast a rate. Use slow speed to clear deep or hard packed snow.

### Tips for Operation

Snow is best removed as soon as possible after snow fall.

To clear an area, run unit in an overlapping series of paths. For large areas, start in the middle and throw snow to each side, so snow is not cleared more than once.

ALWAYS direct snow away from area to be cleared and with direction of the wind.

### TRAVELING

To travel from one work area to another:

1. Press down on handlebars enough to raise front of unit slightly off surface.
2. Engage wheel drive clutch without engaging attachment drive clutch.

### TRANSPORT

ALWAYS shut off engine, remove key, and close fuel shut-off valve when transporting unit on a truck or trailer.

Use extra care when loading or unloading unit onto trailer or truck.

Secure unit chassis to transport vehicle. NEVER secure from rods or linkages that could be damaged.

DO NOT transport machine while engine is running.

## MAINTENANCE

Ariens dealers will provide any service or adjustments which may be required to keep your unit operating at peak efficiency. Should engine service be required, contact an Ariens dealer or an authorized engine manufacturer's service center.



**WARNING:** AVOID INJURY. Read and understand the entire *Safety* section before proceeding.

### SERVICE POSITION



**WARNING:** Before tipping unit up onto housing, remove fuel so no spills will occur. Ensure unit is secure and will not tip over during maintenance.

Place unit on a flat level surface. Tip unit forward onto front of auger housing for service. Ensure unit is secure and will not tip over. Strap and clamp onto bench if needed.

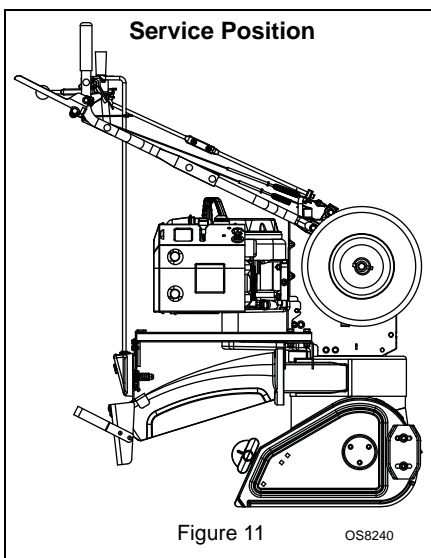

Figure 11

OS8240



## MAINTENANCE SCHEDULE

The chart below shows the recommended maintenance schedule that should be performed on a regular basis. More frequent service may be required.

MAINTENANCE SCHEDULE				
Service Performed	Each Use	Every 5 hrs.	Every 25 hrs.	Yearly
Check Dual Handle Interlock	•			
Check Fasteners	•			
Check Clutch Operation	•			
Check Clutch Spring Adjustments		*	•	
Clean Engine	•			
Check Engine Oil		•		
Change Engine Oil		**	•	
Check Tire Pressure			•	
Check Auger Gearcase			•	•
General Lubrication			•	•

\* After first five hours of operation.

\*\* After first two hours of operation.

### CHECK DUAL HANDLE INTERLOCK

Without the engine running, press down (engage) both clutch levers. Release attachment clutch lever. Attachment clutch should remain engaged until traction clutch lever is released, then both clutches *must* disengage.

### CHECK FASTENERS

Make sure all hardware is tightened properly.

## CHECK CLUTCH OPERATION

Auger / impeller must stop within 5 seconds when attachment clutch/impeller brake lever is released.

Wheels must stop quickly when traction drive clutch lever is released.

If clutches do not engage or disengage properly, adjust or repair before operation (see *Attachment Clutch/Brake Adjustment* on page 23 and *Traction Drive Clutch Adjustment* on page 25).

### CHECK CLUTCH SPRING ADJUSTMENT

Make sure the attachment clutch and traction drive clutch are adjusted to the range specified in *Attachment Clutch/Brake Adjustment* on page 23 and *Traction Drive Clutch Adjustment* on page 25.

### CLEAN ENGINE

Refer to engine manual for detailed instructions.

### CHECK ENGINE OIL

The engine crankcase oil should be checked every 5 hours of operation. Oil level **MUST** be maintained in safe operating range on dipstick at all times or engine damage will result (See engine manual).

Park unit on a level surface. Refer to engine manual for detailed instructions.

### CHANGE ENGINE OIL

Change oil after first 2 hours of operation, thereafter change oil every 25 hours (more often if required). Refer to engine manual for detailed instructions.

Run engine just prior to changing oil. Warm oil will flow more freely and carry away more contamination. Remove the oil drain plug from the side of the unit and tip the unit to help drain all the oil.

### CHECK TIRE PRESSURE

Keep tires at pressure listed on the tire sidewall (see *Check Tire Pressure* on page 10).

### CHECK AUGER GEARCASE

**IMPORTANT:** Proper oil level must be maintained.

Gear cases are filled to the correct level at the factory. Unless there is evidence of leakage, no additional lubricant should be required. Check oil level each season or every 25 hours of operation.

To ensure adequate lubricant level:

1. Remove filler plug (Figure 12). Lubricant must be at least up to bottom of lubricant filler hole with unit resting on a level surface.
2. Add lubricant if required. Allow oil to drain to level of plug and replace plug.

**IMPORTANT:** Use only Ariens special gear lubricant L-2 (Part Number 00008000). Gearcase filler plug may require an application of Loc-Tite® 565 thread sealant with repeated servicing.

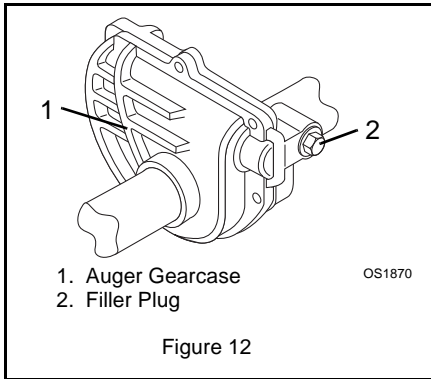

Figure 12

## GENERAL LUBRICATION

**IMPORTANT:** Wipe each fitting clean before and after lubrication. Do not wipe gearcase filler plug; wiping the gearcase filler plug may remove thread sealant and cause leaks.

**IMPORTANT:** DO NOT allow grease or oil to get on friction disc, friction plate or belts.

**NOTE:** Apply Ariens Hi-Temp Grease or equivalent to the lubrication fittings. See *SERVICE PARTS* on page 27.

The unit should be lubricated (Figure 13) at beginning of season or every 25 operating hours.

## Auger Shaft

**NOTE:** To grease auger shaft, remove shear bolt nuts, and shear bolts. Apply grease at the grease zerks and then turn the auger assemblies on the auger shaft. Replace shear bolts per instructions in *Shear Bolts* on page 19.

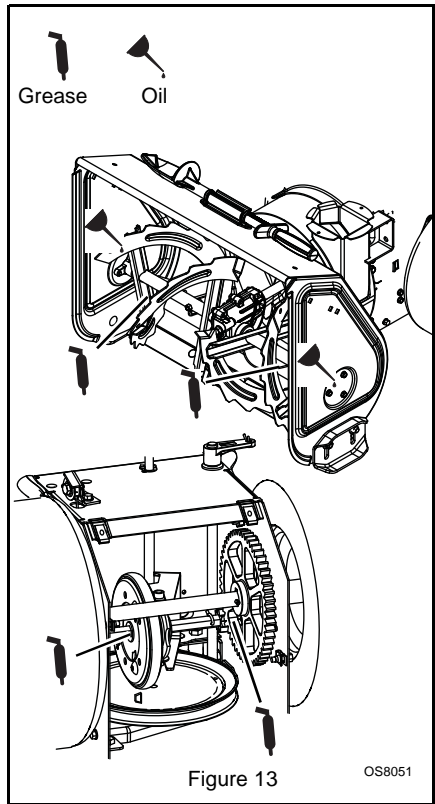

Figure 13

## SERVICE AND ADJUSTMENTS



**WARNING: AVOID INJURY.** Read and understand the entire *Safety* section before proceeding.

## SCRAPER BLADE

**IMPORTANT:** Damage to auger/impeller housing will result if blade wears down too far.

Scraper blade is adjustable to compensate for wear.

To adjust scraper blade:

1. Tip unit back onto handlebar, support housing and loosen nuts retaining blade.

2. Adjust skid shoes to fully raised position (housing closest to ground).
3. Reposition scraper blade flush with skid shoes and tighten lock nuts.

## SKID SHOES

Skid Shoes should be adjusted as conditions require (Figure 14).

1. Position unit on a hard, flat, smooth level surface.

- Adjust skid shoes by inserting a spacer of desired thickness under center of scraper blade, loosen skid shoe hardware, slide skid shoes to flat surface. Allow 1/8 in. (3 mm) between scraper blade and hard smooth surfaces. Allow 1-1/4 in. (30 mm) between scraper blade and uneven or gravel surfaces. Retighten hardware.

**NOTE:** Keep housing level by adjusting skid shoes equally.

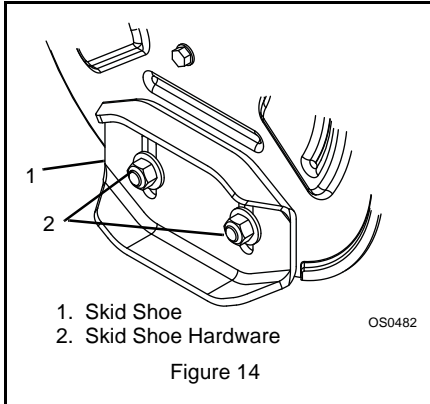

## SHEAR BOLTS

**IMPORTANT:** Use only Ariens shear bolts for replacement. Use of any other type of shear bolt may result in severe damage to unit and may void the warranty.

Occasionally a foreign object may enter the auger/impeller housing and jam the auger, breaking shear bolts which secure the auger to the shaft (Figure 15). This allows auger to turn freely on the shaft which may help prevent damage to gear case and its components.

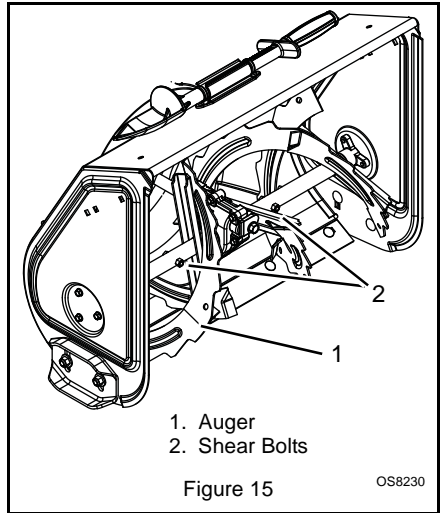

### For Replacement:

- Align shear bolt holes in auger with shear bolt holes in the shaft.
- Drive shear bolt through hole (if shear bolt was broken this will drive remaining part from shaft).
- Secure shear bolt with nut.

## DISCHARGE CHUTE DEFLECTOR

Deflector must stay in selected position while throwing snow.

To adjust, loosen then retighten the wing knob to desired tension (Figure 16).

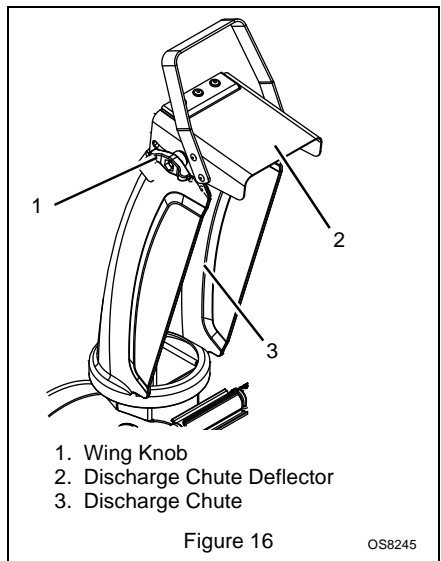

## DISCHARGE CHUTE

If discharge chute does not stay in position while operating, tighten nut on carriage bolt at pivot point to increase tension on spring (Figure 17).

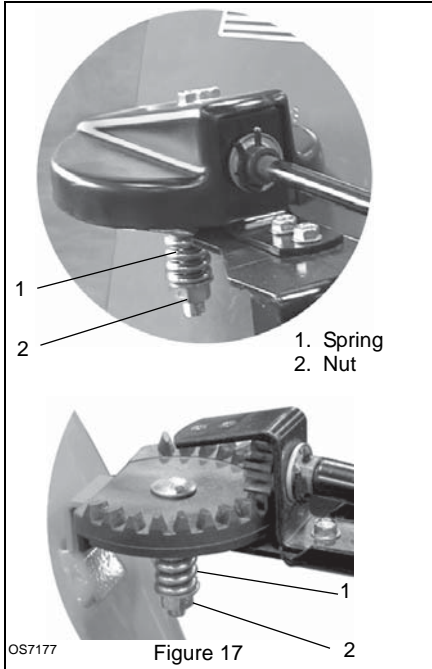

## SPEED SELECTOR ADJUSTMENT

To adjust (Figure 18):

1. Disconnect adjustment pivot pin from speed selector arm. Save hardware for reinstallation.
2. Place the speed selector on dash panel in the fastest forward speed position.
3. Turn the speed selector arm straight down towards the ground as far as it will go.
4. Thread the adjustment pivot pin along the shift rod until it aligns with the mating hole on the speed selector arm, and then turn it up the shift rod 3 turns. Insert the pivot pin into hole.
5. Connect the pivot pin to the speed selector arm with the hardware removed in step 1.
6. Check forward and reverse speeds:
  - a. Start unit.
  - b. Shift speed selector into the first forward speed.
  - c. Engage the traction clutch. Unit should move forward.

- d. Stop unit.
  - e. Shift speed selector into first reverse speed.
  - f. Engage the traction clutch. Unit should move backward.
  - g. Shut off unit.
7. Adjust pivot pin on the shift rod as necessary so unit travels forward when speed selector is in first forward position and travels backward when speed selector is in first reverse position.
  8. Connect the pivot pin to the speed selector arm with the hardware removed in step 1.

**NOTE:** If first forward speed is too fast, disconnect adjustment pivot pin from speed selector arm. Rotate pivot pin to move it up the shift rod a maximum of two turns and reconnect pivot pin to speed selector arm.

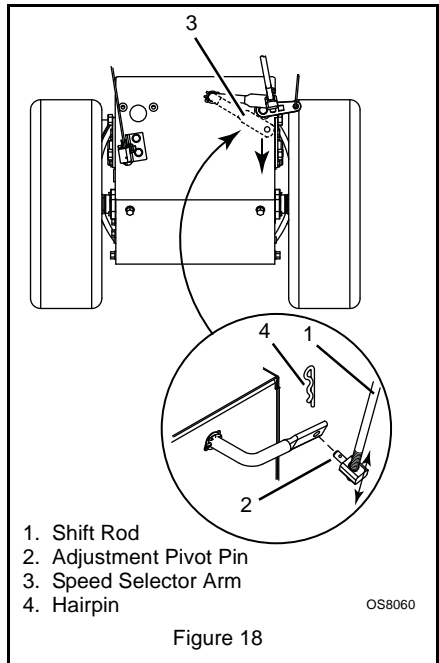

## ATTACHMENT DRIVE BELT REPLACEMENT

### Remove Attachment Drive Belt

(Figures 19, 20 and 21)

1. Shut off engine, remove key, disconnect spark plug wire and allow unit to cool completely.
2. Remove two screws securing belt cover to unit and remove belt cover.
3. Remove spring pin from chute crank and separate.

- Remove belt finger by removing cap screws mounting belt finger to engine (Figure 20 or Figure 21).
- Remove attachment drive belt from engine sheave (it may be necessary to turn engine sheave using recoil starter handle).

**CAUTION:** Always support the unit frame and housing when loosening the cap screws holding them together. Never loosen cap screws while unit is in service position.

**IMPORTANT:** To avoid bending bottom cover, when tipping unit apart, support handlebars firmly or tip unit up on housing and remove bottom cover by removing six cap screws before separating unit.

- Support the frame and housing.
- Remove hex bolts securing housing to frame (two on each side). Tip housing and frame apart on pivot pin.
- Remove attachment drive belt from attachment pulley (hold brake away from belt).

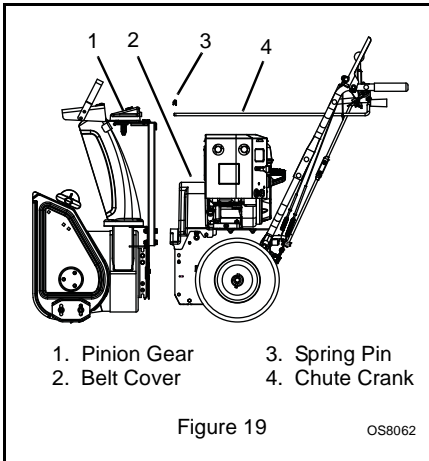

### Replace Attachment Drive Belt

- Place new belt onto attachment pulley.

**NOTE:** Holding down the attachment clutch lever will make it easier to reconnect the housing and frame.

- Tip housing and frame back together and secure with hex bolts.
- Place belt onto engine sheave.
- Replace belt finger.

**IMPORTANT:** With the clutch lever engaged, the belt finger located opposite the belt idler must be less than 1/8 in. (3.2 mm) from the belt, but not touching the belt, or belt grabbing may occur causing impeller to rotate while the attachment clutch is disengaged (Figure 21).

- Adjust clutch per *Attachment Clutch/Brake Adjustment* on page 23.

**WARNING:** AVOID INJURY. Auger must stop within 5 seconds when attachment lever is released or serious injury or unit damage may result.

- Replace chute crank and secure with spring pin.
- Run in the attachment belt. See *Run-in Attachment Belt* on page 10.
- Replace belt cover.

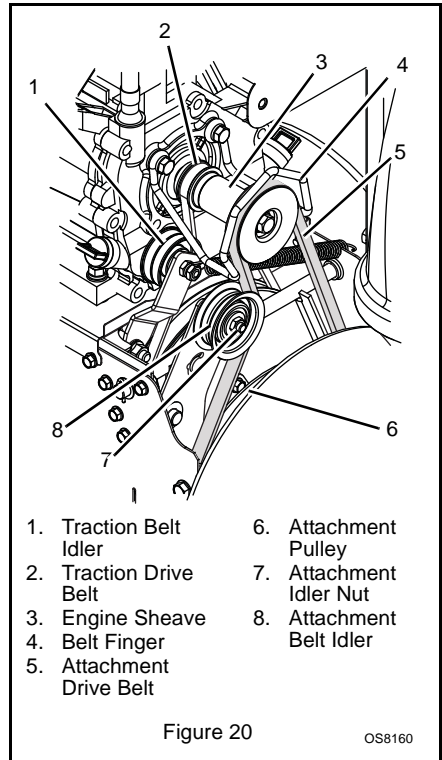

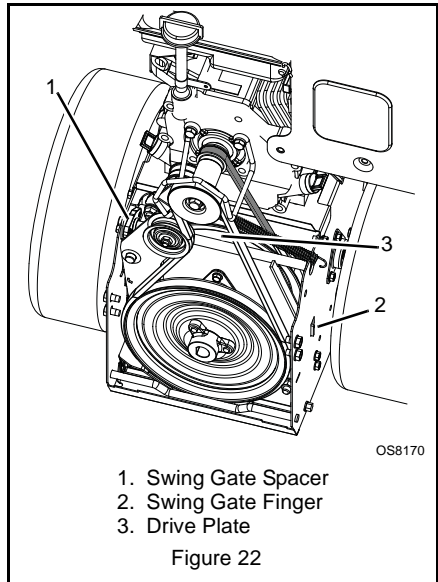
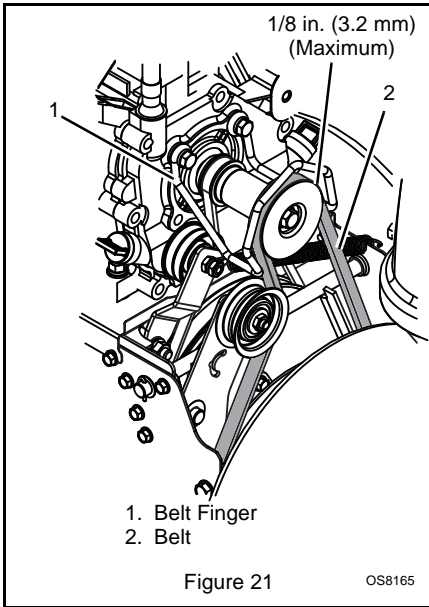

## TRACTION DRIVE BELT REPLACEMENT

**NOTE:** Housing and frame must be tipped apart and attachment drive belt removed from engine sheave in order to change traction drive belt (Figures 19, 20, 21, 22 and 23)



**CAUTION:** Always support the frame and blower housing when loosening the cap screws holding them together. Never loosen cap screws while unit is in service position.

1. Remove attachment drive belt (See *Remove Attachment Drive Belt* on page 20).

**NOTE:** To gain belt clearance, remove swing gate spacer (Figure 22) so drive plate can be slid over until finger is out of frame and drive plate can swing past stop hole in frame. See Figure 23.

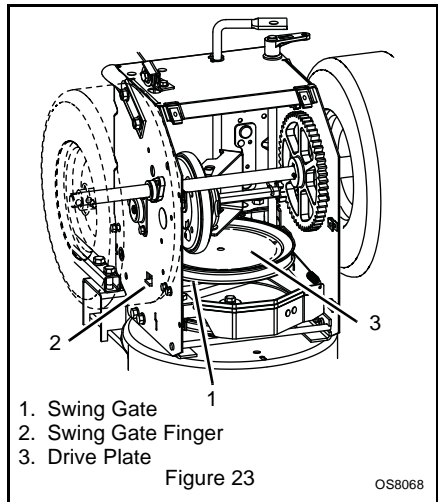

2. Pull idler away from traction drive belt and remove belt from idler, crankshaft pulley and driven pulley (it may be necessary to turn crankshaft pulley using recoil starter handle).
3. Replace traction drive belt.
4. Swing drive plate toward friction disc to slide finger into stop hole in frame. Reinstall swing gate spacer.

**NOTE:** Make sure drive plate spring remains connected to the frame and drive plate.

5. Replace attachment drive belt (See *Replace Attachment Drive Belt* on page 21).

# ATTACHMENT CLUTCH/BRAKE ADJUSTMENT



**WARNING: IMPROPER ADJUSTMENT** could result in unexpected movement of auger and impeller causing death or serious injury. AUGER / IMPELLER MUST STOP within 5 seconds when attachment clutch/impeller brake lever is released.



**WARNING:** Adjustment procedure requires the engine to be run with the belt cover off. AVOID INJURY. Read and understand the entire *Safety* section before proceeding.

## Remove Attachment Cable Slack

1. Remove the belt cover.
2. Loosen jam nut on cable adjustment barrel, and then turn the adjustment barrel down to shorten cable and remove all cable slack. See Figure 24.

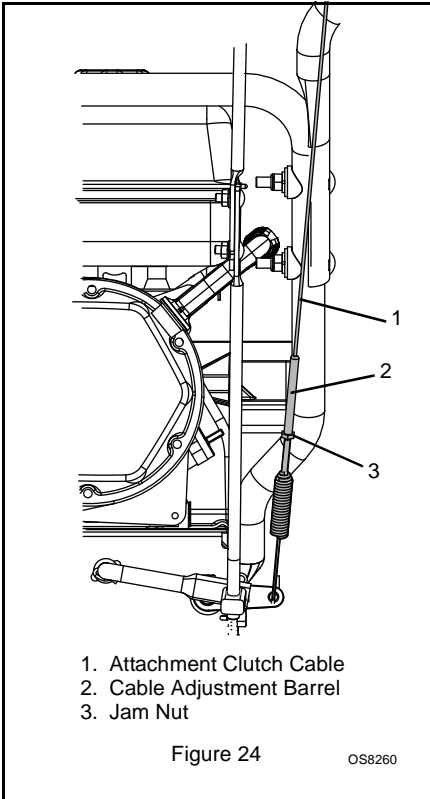

3. With the attachment clutch disengaged, check that the attachment idler arm lightly touches the frame. See Figure 25.
4. Tighten jam nut on cable adjustment barrel.

With the attachment clutch disengaged, check the attachment idler arm position here. The attachment idler arm should lightly touch the frame.

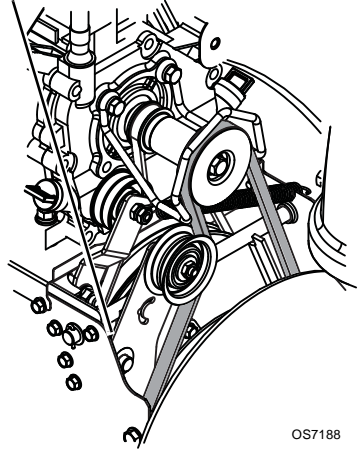

Figure 25

## Check Attachment Idler Arm Roller Clearance

1. Place the unit into the service position. Remove the bottom cover.
2. With the clutch lever engaged, check the clearance between the frame and plastic roller on the lower end of the attachment idler arm. See Figure 26.
  - If roller is 1/2 – 7/8 in. (12.7 – 22.2 mm) from frame, go to *Adjust the Attachment Clutch Cable Spring Extension* on page 24.
  - If roller is less than 1/2 in. (12.7 mm) from frame, loosen idler adjustment nut and move idler closer to the belt. Tighten adjustment nut and recheck the roller clearance.
  - If roller is more than 7/8 in. (22.2 mm) from frame, loosen idler adjustment nut and move idler away from the belt. Tighten adjustment nut and recheck roller clearance.

Roller should be  $1/2 - 7/8$  in. (12.7 – 22.2 mm) from the frame when the attachment clutch is engaged.

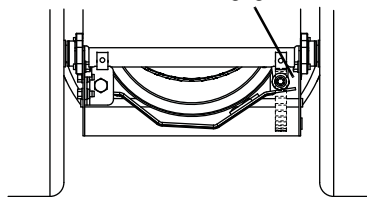

Figure 26

OS8080

## Adjust the Attachment Clutch Cable Spring Extension

1. Check the attachment clutch cable spring extension.

Measure the length of the attachment clutch cable spring with the clutch lever disengaged.

Then measure the attachment clutch spring with the clutch lever engaged. See Figure 27. The spring should be  $1/2 - 9/16$  in. (12.7 – 14.3 mm) longer when the clutch lever is engaged.

- If spring extension is within the specified range, go to *Check Attachment Brake (Figure 28)* on page 24.
- If spring extension is outside of specified range, go to step 2.

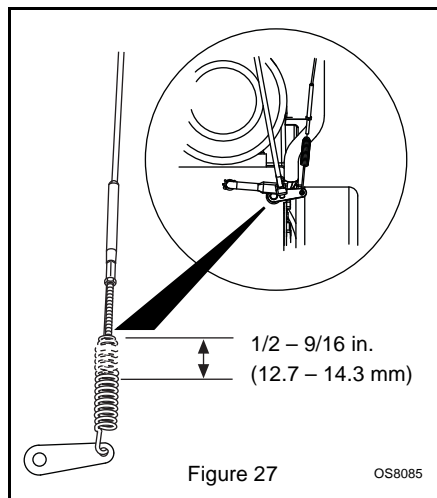

Figure 27

OS8085

2. Adjust cable length (See Figure 27).
  - a. Loosen jam nut on cable.
  - b. To increase spring extension, adjust barrel down the cable and tighten jam nut.
  - c. To decrease spring extension, adjust barrel up the cable and tighten jam nut.

## Check Attachment Brake (Figure 28)

1. With the clutch lever disengaged, brake pad must contact attachment belt. With clutch lever engaged, brake pad must be more than  $1/16$  in. (1.6 mm) from belt. If there is more than  $1/16$  in. (1.6 mm) gap, go to *Check Belt Finger Clearance (Figure 29)* on page 25. If there is less than  $1/16$  in. (1.6 mm) gap, go to Step 2.

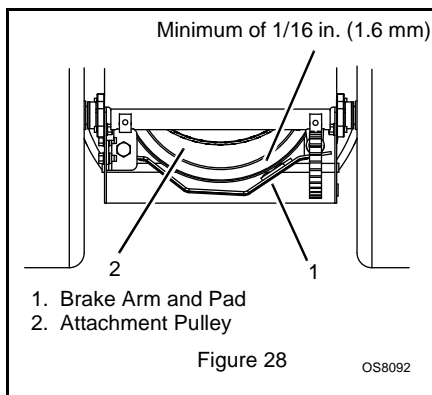

1. Brake Arm and Pad
2. Attachment Pulley

Figure 28

OS8092

2. If there is less than  $1/16$  in. (1.6 mm) gap between brake pad and belt, follow these steps:
  - a. To increase brake pad gap, loosen idler adjustment nut, and move idler away from belt. Position idler to achieve a  $1/16$  in. (1.6 mm) minimum brake pad gap and a  $1/2 - 7/8$  in. (12.7 – 22.2 mm) gap between the plastic roller and the frame.
  - b. Check the clutch cable spring extension and adjust as necessary to achieve a  $1/2 - 9/16$  in. (12.7 – 14.3 mm) spring extension.
  - c. If the cable needed adjustment, recheck gaps described in step 1. Repeat steps as necessary until brake clearance, roller gap and spring extension are within specified ranges.

**IMPORTANT:** If adjustments cannot be brought into specified ranges see your dealer for repairs.



## Check Belt Finger Clearance (Figure 29)

1. With clutch lever engaged, the belt finger located opposite the belt idler must be less than 1/8 in. (3.2 mm) from belt, but not touching the belt.

To adjust belt finger, loosen the bolts and move the finger to the proper position. Tighten the bolts and recheck the belt finger clearance.

2. Replace the belt cover.

Check belt finger clearance here. With the attachment clutch engaged, there should be less than 1/8 in. (3.2 mm) clearance between the belt and the belt finger. The belt finger should not touch the belt.

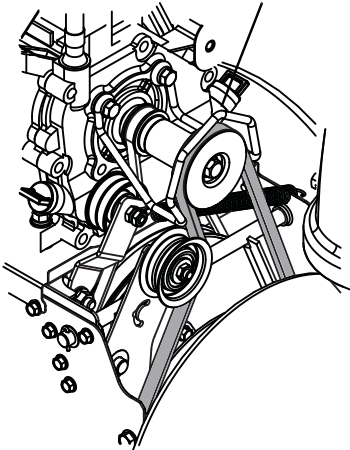

Figure 29

OS8067

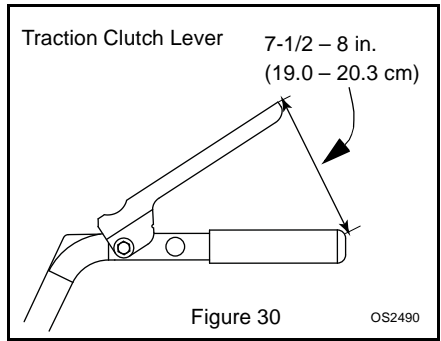

Figure 30

OS2490

To adjust traction clutch (Figure 31):

1. With the traction drive clutch lever disengaged, loosen the jam nut on the cable adjuster.  
Turn adjustment barrel up the cable to decrease the distance between clutch lever and handlebar.  
Turn the adjustment barrel down the cable to increase the distance between clutch lever and handlebar.
2. Check traction clutch lever distance and repeat adjustment steps if necessary.
3. Tighten jam nut on traction cable adjustment barrel.
4. With the clutch disengaged, check that there is more than 1/32 in. (0.8 mm) clearance between friction disc and drive plate assembly in all speeds. See Figure 32 on page 26.

## TRACTION DRIVE CLUTCH ADJUSTMENT

If drive slips, adjust traction clutch to compensate for friction disc wear.

To test traction clutch (Figure 30):

1. Put unit in first forward speed.
2. Without engine running, push unit forward while slowly moving the traction drive clutch lever toward the handlebar.
3. Measure distance between lever and handlebar when the wheels begin to brake. If distance is not 7-1/2 - 8 in. (19.0 - 20.3 cm), adjust the traction clutch.

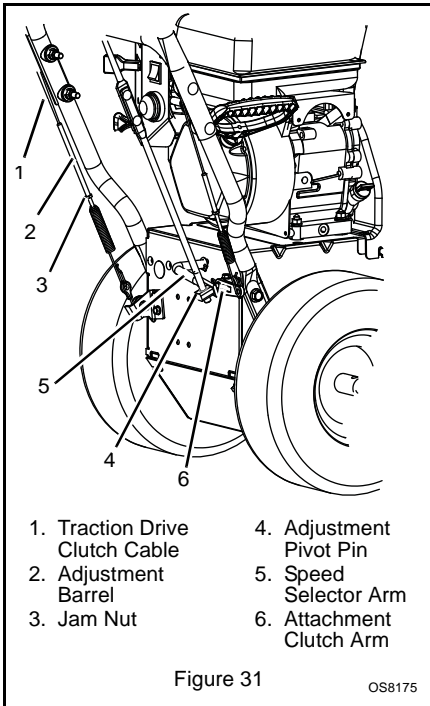

## FRICITION DISC REPLACEMENT

### Remove Friction Disc (Figure 31 and Figure 32):

1. Shut off engine, remove key, disconnect spark plug wire and allow unit to cool completely.



**CAUTION:** Before tipping unit, remove enough fuel so that no spills occur.

2. Place the unit into the service position on a level surface.
3. Remove lockpins from wheel axles and remove wheels.
4. Remove bottom cover by removing six hex bolts.
5. Disconnect pivot pin from the speed selector arm. Save the hardware for reinstallation.
6. Remove spring clip pin nearest drive gear from hex shaft.
7. Remove left bearing flange from frame.
8. Slide hex shaft to the left to remove the flat washer, pinion gear and friction disc assembly from the hex shaft.

**NOTE:** Be sure to save washers between bearing and sliding fork for reassembly.

9. Remove friction disc assembly from frame.
10. Remove three screws holding friction disc to carrier bearing.
11. Remove old friction disc. Put the new friction disc in place, cup side to carrier bearing.
12. Reinstall three screws into new friction disc and carrier bearing. Torque to 5 – 6 lbf-ft. (6.8 – 8.13 N•m).

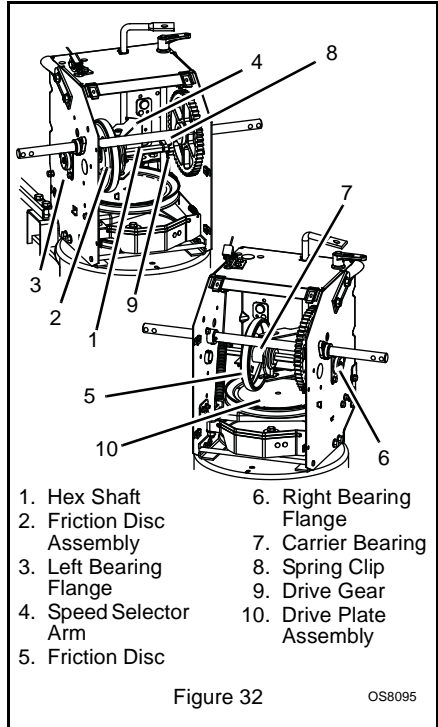

13. Insert new friction disc assembly into frame. Install washers onto carrier bearing and slide into speed selector arm.
14. Slide hex shaft through new friction disc assembly. Install pinion gear and washer onto hex shaft and slide shaft into right bearing.
15. Install left bearing flange using hardware removed in step 7.
16. Reinstall clip pin into hex shaft.
17. Connect pivot pin to speed selector arm. See *Speed Selector Adjustment* on page 20.
18. Install bottom cover.
19. Reinstall wheels.
20. Return unit to upright position.
21. Connect spark plug wire to spark plug.
22. Adjust traction drive clutch. See *Traction Drive Clutch Adjustment* on page 25.

## STORAGE



**WARNING: AVOID INJURY.** Read and understand the entire *Safety* section before proceeding.

### SHORT TERM

**IMPORTANT:** NEVER spray unit with high pressure water or store unit outdoors.

Run with attachment clutch engaged a few minutes after each use to free unit of any loose or melting snow.

Close fuel shut-off valve.

Inspect unit for visible signs of wear, breakage or damage.

Keep all nuts, bolts and screws properly tightened and know unit is in safe working condition.

Store unit in a cool, dry protected area.

### LONG TERM

Clean unit thoroughly with mild soap and low pressure water and lubricate (see *MAINTENANCE* on page 16). Touch up all scratched painted surfaces.

Remove weight from wheels by putting blocks under frame or axle.

## Fuel System

Gasoline left in the fuel system for extended periods without a stabilizer will deteriorate, resulting in gum deposits in the system. These deposits can damage the carburetor and the fuel hoses, filter and tank. Prevent deposits from forming in the fuel system during storage by adding a quality fuel stabilizer to the fuel. Follow the recommended mix ratio found on the fuel stabilizer container.

To treat the fuel system for storage:

1. Add fuel stabilizer according to manufacturers's instructions.
2. Run engine for at least 10 minutes after adding stabilizer to allow it to reach the carburetor.

NEVER store the engine with fuel in the fuel tank inside of a building with potential sources of ignition.

## SERVICE PARTS

Order the following parts through your dealer:

Part No.	Description
00036800	Ariens Hi-Temp Grease (3, 3 oz. cartridges)
21547400	Spark Plug
07200513	Impeller Belt
07200101	Traction Belt
53200500	Shear Bolts
00170800	Friction Disc
00592900	Gas Stabilizer (4 oz.)

## ACCESSORIES

See your authorized Ariens dealer to add the additional accessories available to your Sno-Tek model.

Part No.	Description
72000200	Slicer Bar
72406500	Front Weight Kit
72600300	Composite Skid Shoe Kit
73203600	Snow Thrower Cover

## TROUBLESHOOTING

PROBLEM	PROBABLE CAUSE	CORRECTION
<b>Engine will not crank/start.</b>	<ol style="list-style-type: none"> <li>1. Fuel tank is empty.</li> <li>2. Fuel shut-off valve closed.</li> <li>3. Build up of dirt and residue around governor/carburetor.</li> <li>4. Key switch not in run position.</li> <li>5. Engine start switch turned off.</li> </ol>	<ol style="list-style-type: none"> <li>1. Fill fuel tank.</li> <li>2. Open fuel shut-off valve.</li> <li>3. Clean area around governor/carburetor.</li> <li>4. Put Key switch into run position.</li> <li>5. Turn switch on. See <i>Starting and Shut Off</i> on page 15.</li> </ol>
<b>Engine stops.</b>	<ol style="list-style-type: none"> <li>1. Out of fuel.</li> <li>2. Fuel shut-off valve closed.</li> <li>3. Mechanical jam in auger or impeller.</li> <li>4. Contaminated fuel supply.</li> <li>5. Faulty spark plug.</li> </ol>	<ol style="list-style-type: none"> <li>1. Fill fuel tank.</li> <li>2. Open fuel shut-off valve.</li> <li>3. Turn off engine, remove key, and wait for all moving parts to stop. Check for and remove obstruction and repair before restart.</li> <li>4. Replace with clean fuel.</li> <li>5. Replace or clean spark plug.</li> </ol>
<b>Engine problems.</b>	<ol style="list-style-type: none"> <li>1. See Engine Manual.</li> </ol>	
<b>Does not operate in Forward / Reverse.</b>	<ol style="list-style-type: none"> <li>1. Friction disc not adjusted properly.</li> <li>2. Traction belt not functioning.</li> <li>3. Speed selector not adjusted properly.</li> </ol>	<ol style="list-style-type: none"> <li>1. Repair or replace friction disc (see <i>Friction Disc Replacement</i> on page 26).</li> <li>2. Repair or replace traction drive belt (see <i>Traction Drive Belt Replacement</i> on page 22).</li> <li>3. Adjust speed selector (see <i>Speed Selector Adjustment</i> on page 20).</li> </ol>
<b>Small rubber beads collect in frame</b>	<ol style="list-style-type: none"> <li>1. Friction disc wear.</li> </ol>	<ol style="list-style-type: none"> <li>1. Normal friction disc wear. Chunks or large pieces of rubber mean friction disc should be checked and replaced as necessary.</li> </ol>
<b>Unit throws snow poorly or does not throw snow.</b>	<ol style="list-style-type: none"> <li>1. Shear bolts broken.</li> <li>2. Attachment clutch/brake not adjusted properly.</li> <li>3. Auger is frozen in place.</li> <li>4. Ice or debris is obstructing auger.</li> <li>5. Attachment drive belt slipping, worn or damaged.</li> </ol>	<ol style="list-style-type: none"> <li>1. Replace shear bolts (see <i>Shear Bolts</i> on page 19).</li> <li>2. Adjust attachment clutch/brake (see <i>Attachment Clutch/Brake Adjustment</i> on page 23).</li> <li>3. Move unit to a warm place to thaw.</li> <li>4. With the engine off and auger disengaged, check for obstructions and remove.</li> <li>5. Adjust or replace attachment drive belt (see <i>Attachment Clutch/Brake Adjustment</i> on page 23).</li> </ol>

## SPECIFICATIONS

<b>Model Number</b>	920400	920401
<b>Description</b>	Sno-Tek 24	Sno-Tek 26
<b>Engine</b>	LCT Storm Force	LCT Storm Force
Gross Torque* - ft-lbs (N-m)	9.5 (12.9)	9.5 (12.9)
Displacement - in. (cc)	12.7 (208)	12.7 (208)
High Idle - RPM (min)	3600 ± 50	3600 ± 50
Start	Recoil	Recoil
Fuel Tank Capacity - qt (Liters)	4.0 (3.8)	4.0 (3.8)
<b>Chute</b>		
Chute Rotation Angle	205°	205°
Rotation Control	2.5X Quick Turn	2.5X Quick Turn
Deflector Control	Manual	Manual
<b>Auger</b>		
Snow Clearing Width - in. (cm)	24.0 (61.0)	26.0 (66.0)
Gear Case	Aluminum	Aluminum
Auger Diameter - in. (cm)	11.0 (27.9)	11.0 (27.9)
<b>Impeller</b>		
Impeller Diameter - in. (cm)	12.0 (30.5)	12.0 (30.5)
Impeller Speed (RPM)	1320	1320
Impeller Tip Speed - ft/min (m/min)	4146 (1264)	4146 (1264)
<b>Drive</b>		
Blower Drive	HA Belt	HA Belt
Drive System	Disc-O-Matic®	Disc-O-Matic®
Speeds	6 Forward and 2 Reverse	6 Forward and 2 Reverse
Axle Control	Pin-Lock	Pin-Lock
Pneumatic Tires - in.	13 x 4-6	15 x 5-6
<b>Size and Weight</b>		
Length - in. (cm)	51.9 (131.8)	50.8 (129.0)
Height - in. (cm)	43.3 (110.0)	45.4 (115.3)
Width - in. (cm)	26.4 (67.1)	28.4 (72.1)
Weight - lbs (Kg)	169 (76.7)	174 (78.9)
*Engine output stated in gross torque per SAE J1940 as rated by engine manufacturer.		



## Sno-Tek™ Two-Year Limited Warranty

Ariens Company (Ariens) warrants to the **original purchaser** that Sno-Tek brand products will be free from defects in material and workmanship for a period of two years after the date of purchase. An authorized Ariens dealer will repair any defect in material or workmanship, and repair or replace any defective part, subject to the conditions, limitations and exclusions set forth herein. Such repair or replacement will be free of charge to the original purchaser (labor and parts), except as noted below.

The duration of this warranty applies only if the product is put to personal use around a household or residence. If the product is put to any business use, agricultural, commercial, or industrial, then the duration of this warranty shall be 90 days after the date of purchase. If any product is rented or leased, then the duration of this warranty shall be 90 days after the date of purchase. It is the owner's responsibility to perform correctly the maintenance and minor adjustments explained in the owner's manual.

### ***Service Parts and Accessories Warranty***

- Genuine Ariens brand service parts and accessories are warranted to be free from defects in material and workmanship for a period of 90 days after the date of purchase. An authorized Ariens dealer will repair or replace any such part or accessory free of charge, except for labor, during that period.

## **Exceptions, Limitations, Exclusions**

### ***Customer Responsibilities***

**Register the product immediately at the time of sale.** If the dealer does not register the product, the customer must complete the product registration card in the literature package and return it to the Ariens Company, or register the unit online at [www.ariens.com](http://www.ariens.com).

To obtain warranty service, the **original purchaser** must:

- Perform the maintenance and minor adjustments explained in the owner's manual.
- Promptly notify Ariens or an authorized Ariens service representative of the need for warranty service.
- Transport the product to and from the place of warranty service.
- Have the warranty service performed by an authorized Ariens service representative.

To find an Ariens authorized service representative, contact Ariens at:

655 W. Ryan Street  
Brillion, WI 54110  
(920) 756 - 2141  
[www.ariens.com](http://www.ariens.com)

### ***Limitations***

- Friction discs, belts, idlers, cables, and electrical components on Sno-Tek models put to personal use around a household or residence are warranted against defects in materials or workmanship to the **original purchaser** for two years.

## Exclusions – Items Not Covered by This Warranty

- Engines and engine accessories are covered only by the engine manufacturer's warranty and are not covered by this warranty.
- Parts that are not genuine Ariens service parts are not covered by this warranty and may void the warranty.
- Damages resulting from the installation or use of any part, accessory or attachment which is not approved by the Ariens Company for use with product(s) identified herein are not covered by this warranty.
- The following maintenance, service and replacement items are not covered by this warranty unless they are noted in the Limitations section above: lubricants, spark plugs, oil, oil filters, air filters, shoes, runners, scraper blades, shear bolts, headlights, light bulbs.
- Any misuse, alteration, improper assembly, improper adjustment, neglect, or accident which requires repair is not covered by this warranty.
- This warranty applies only to products purchased in the United States (including Puerto Rico) and Canada. In all other countries, contact place of purchase for warranty information.

### **Disclaimer**

Ariens may from time to time change the design of its products. Nothing contained in this warranty shall be construed as obligating Ariens to incorporate such design changes into previously manufactured products, nor shall such changes be construed as an admission that previous designs were defective.

### **LIMITATION OF REMEDY AND DAMAGES**

Ariens Company's liability under this warranty, and under any implied warranty that may exist, is limited to repair of any defect in workmanship, and repair or replacement of any defective part. Ariens shall not be liable for incidental, special, or consequential damages (including lost profits). Some states do not allow the exclusion of incidental or consequential damages, so the above limitation or exclusion may not apply to you.

### **DISCLAIMER OF FURTHER WARRANTY**

**Ariens Company makes no warranty, express or implied, other than what is expressly made in this warranty. If the law of your state provides that an implied warranty of merchantability, or an implied warranty of fitness for particular purpose, or any other implied warranty, applies to Ariens Company, then any such implied warranty is limited to the duration of this warranty. Some states do not allow limitations on how long an implied warranty lasts, so the above limitation may not apply to you.**

*This warranty gives you specific legal rights, and you may also have other rights which vary from state to state.*



Ariens Company  
655 West Ryan Street  
Brillion, WI 54110-1072  
920-756-2141  
[www.ariens.com](http://www.ariens.com)



## **WARNING**



The engine exhaust from this product contains chemicals known to the State of California to cause cancer, birth defects or other reproductive harm.