



Rapid XZ

Parts Manual

Models

990100 - 27hp

990101 - 25hp

990102 - 30hp



Shown with optional 60" deck.

THE MANUAL

Before you operate your unit, carefully and completely read manuals supplied with the unit. The contents will provide you with an understanding of safety instructions and controls during normal operation and maintenance.

For your safety and the safety of others always read, understand, and follow all DANGER, WARNING, and CAUTION messages found in manuals and on safety decals.

Hardware descriptions are given in decimals.

Decimals to Fractions			
.063	1/16	.563	9/16
.125	1/8	.625	5/8
.188	3/16	.688	11/16
.250	1/4	.750	3/4
.313	5/16	.813	13/16
.375	3/8	.875	7/8
.438	7/16	.938	15/16
.500	1/2	1.00	1

SERVICE AND REPLACEMENT PARTS

When ordering replacement parts or making service inquiries, know the Model and Serial numbers of your unit and engine.

Numbers are located on the product registration card in the unit literature package. They are printed on a serial number label, located on the frame of your unit.

• Record Unit Model and Serial numbers here:

• Record Engine Model and Serial numbers here:

UNAUTHORIZED REPLACEMENT PARTS

Use only Gravelly replacement parts. The replacement of any part on this vehicle with anything other than a Gravelly authorized replacement part may adversely affect the performance, durability, or safety of this unit and may void the warranty. Gravelly disclaims liability for any claims or damages, whether warranty, property damage, personal injury or death arising out of the use of unauthorized replacement parts.

PRODUCT REGISTRATION

The Gravelly dealer must register the product at the time of purchase. Registering the product will help the company process warranty claims or contact you with the latest service information. All claims meeting requirements during the limited warranty period will be honored, whether or not the product registration card is returned. Keep a proof of purchase if you do not register your unit.

Customer Note: If Dealer does not register your product, please fill out, sign and return the product registration card to Gravelly or go to www.gravelly.com.

YOUR SATISFACTION IS IMPORTANT

Questions? Please follow these helpful steps:

1. Refer to the manuals supplied with your unit.
They will guide you through safe and proper operation and maintenance.
They contain specifications on your unit.
If your questions are not answered in these manuals, go to step number two.
2. Contact Your Dealer.
Our dealers will be happy to supply any service or advice required to keep your unit operating at peak efficiency.
A factory trained staff is available to support your equipment needs. They stock genuine Gravelly parts and lubricants manufactured with the same precision and skill as the original.
If your questions are not resolved by the support staff, ask for the manager or owner.
When contacting your Dealer supply your model and serial numbers.

TO SPEED PARTS ORDERING:

1. Know the model and serial numbers of your unit.
2. Know the part number required.
3. Know the quantity required.
4. Know the part description.

MODELS

Domestic

Model 990100

Rapid XZ, 27hp Kohler
Horizontal
Serial No. 000100 and up

Model 990101

Rapid XZ, 25hp Kohler
Horizontal
Serial No. 000100 and up

Model 990102

Rapid XZ, 30hp Kohler
Horizontal
Serial No. 000100 and up

TABLE OF CONTENTS

DECALS

Decals 4

MAIN FRAME

Frame 5

Seat 6

POWER PLANT

Hood 8

Engine and Clutch 10

Fuel Tanks and Hoses 12

DRIVE TRAIN

Hydrostatic Pumps and Idlers 14

Rear Axle and Weights 16

OPERATOR CONTROLS

Brake Linkage 18

Steering Levers & Linkages 20

Control Panel 22

HYDRAULICS

Weight Transfer 24

Hydraulic Tank, Filter, Pumps, & Hoses 26

Hydraulic Routing Diagram 28

ELECTRICAL

Electrical System 30

Continuity Diagram 32

Wiring Diagram 33

DECALS

Model 990100, 101, 102

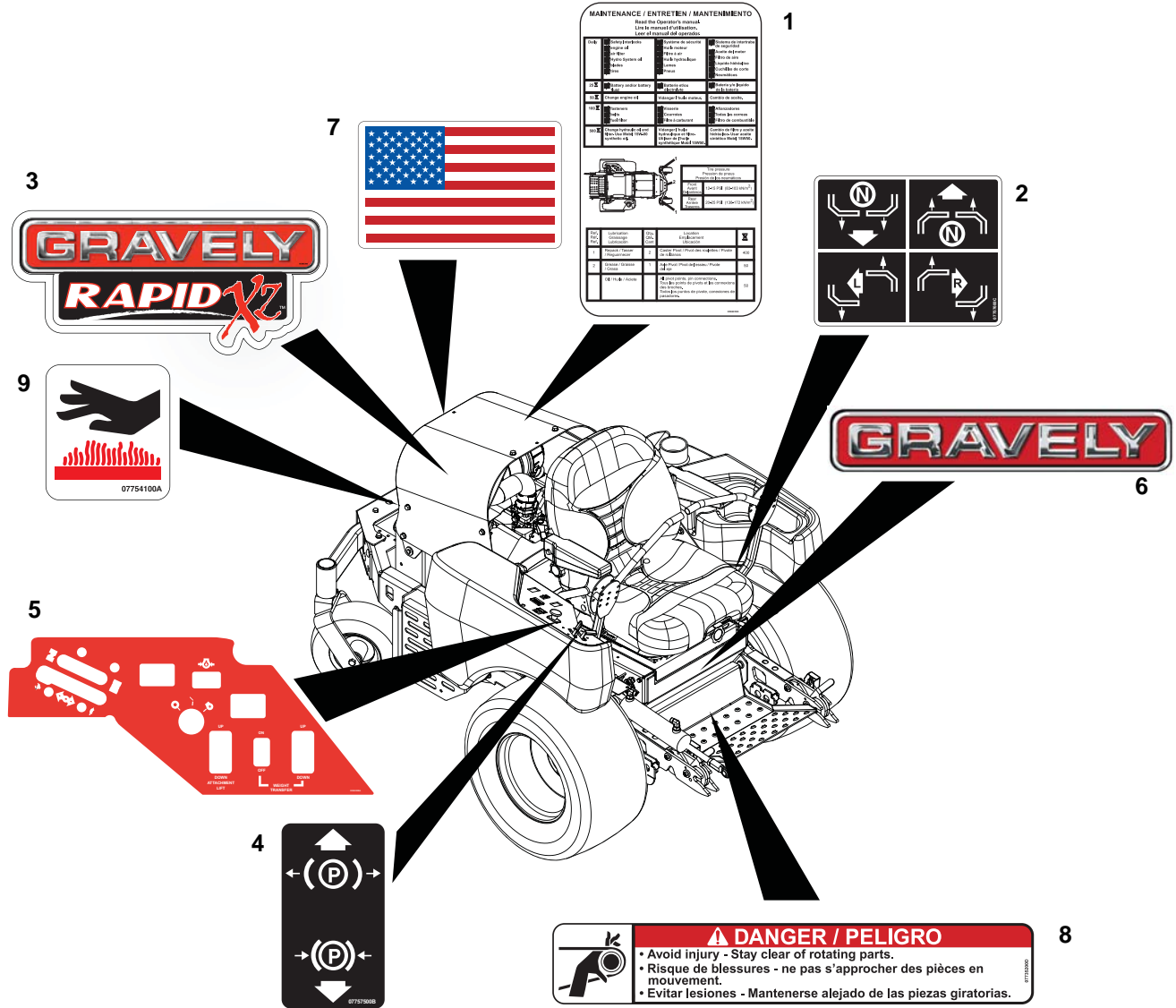

Item	Part No.	Qty.	Description
1	05363100	1	Decal, Service Instructions Rapid XZ
2	07757600	1	Decal, Instructional Steering
3	05363300	2	Decal, Gravely Rapid XZ Hood
4	07757500	1	Decal, Parking Brake Lever
5	05363000	1	Decal, Control Panel Rapid XZ
6	05231800	1	Decal, Gravely Logo
7	05305100	1	Decal, American Flag
8	07735200	2	Decal, Danger
9	07754100	1	Decal, Hot Surface

PD3283

FRAME

Model 990100, 101, 102

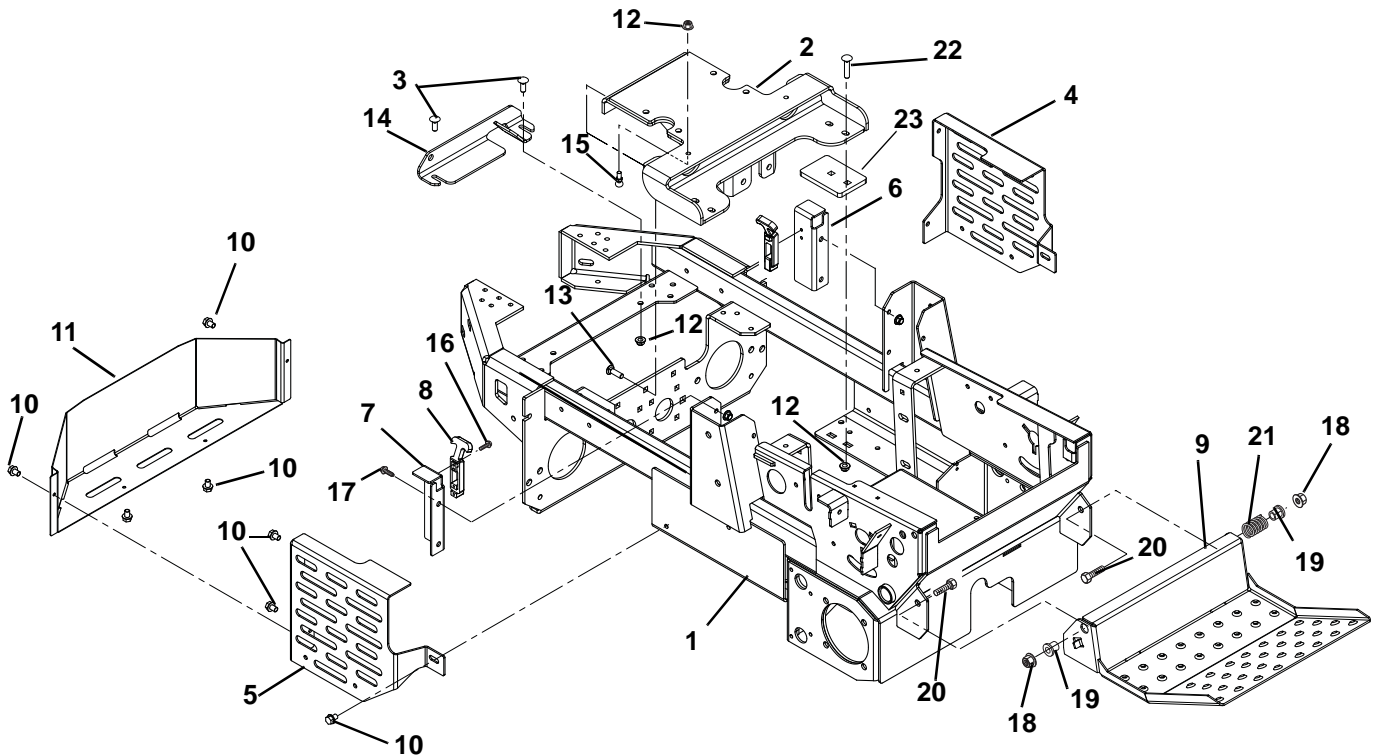

Item	Part No.	Qty.	Description
1	00474551	1	Weldment, Frame
2	00601451	1	Plate, Kohler Engine Mounting
3	06223600	2	Bolt, Round Head Square Neck .38-16 x 1.00 Grade 5
4	00668151	1	Guard, Hose Fitting - Left Hand
5	00666451	1	Guard, Hose Fitting - Right Hand
6	00664951	1	Bracket, Left Hand Hood Mounting
7	00665051	1	Bracket, Right Hand Hood Mounting
8	09079500	2	Latch, Rubber
9	00589153	1	Weldment, Foot Plate
10	07415400	10	Screw, Tapping .38-16 x .75 Hex Washer Head
11	00653551	1	Guard, Pump Belt
12	06545500	11	Nut, .38-16 Nyloc Flange
13	06224100	3	Bolt, Round Head Square Neck .38-16 x 1.25 Grade 5
14	00390951	1	Weldment, Clutch Stop
15	03652200	2	Stud, Ball
16	06116700	4	Screw, Machine 10-24 x .50 Hex Washer Head
17	07412900	4	Screw, Tapping .38-16 x .50 Hex Washer Head Thread Rolling
18	06543600	2	Nut, Locking Top Flange .50-13
19	05527200	2	Bushing, Flange .515 x .746 x 1.290 x 1.000
20	05961000	2	Bolt, Hex .50-13 x 2.25 Grade 5
21	08329100	1	Spring, Compression .085 x .80 x 1.00 WLD36
22	06223800	4	Bolt, Round Head Square Neck .38-16 x 1.75 Grade 5
23	00606051	2	Strap, Engine Mounting Support

SEAT

Model 990100, 101, 102

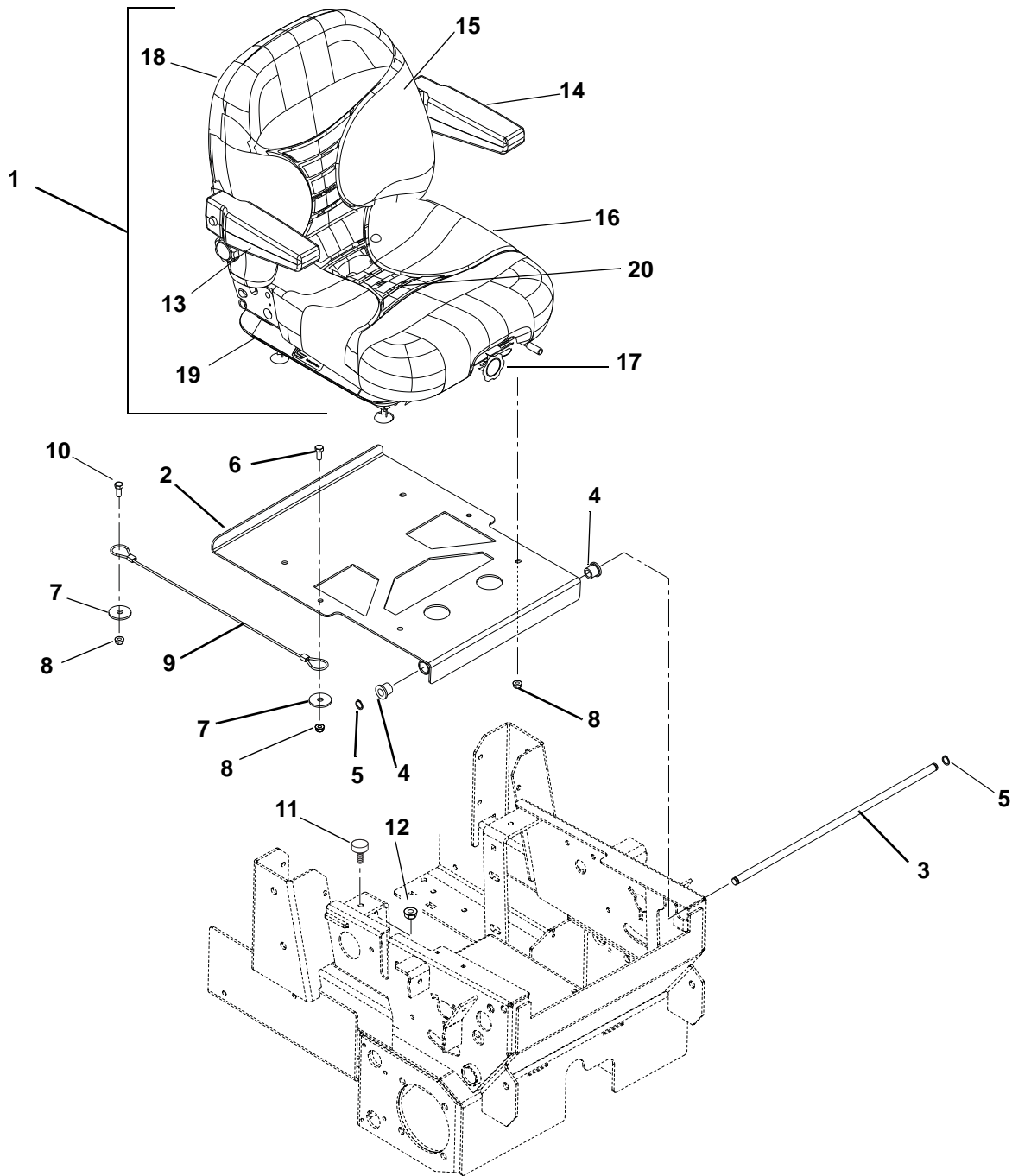

PD0780

SEAT

Model 990100, 101, 102

Item	Part No.	Qty.	Description
1	03947200	1	Seat, Suspension, Light Grey (Includes items 13 – 20)
2	00474151	1	Plate, Seat Pivot
3	00587700	1	Rod, Seat Pivot (Outfront)
4	05521100	2	Bushing, Flange .515 x .750 x .745 x 1.00 Nylon
5	05717100	2	Ring, Retaining External .500 x .050
6	05947000	1	Bolt, Hex .31-18 x .75 Grade 5
7	06446300	2	Washer, Flat Steel .344 x 1.125 x .135
8	06545400	6	Nut, Nyloc Flange .31-18
9	06900010	1	Cable, Seat Prop
10	06216100	1	Bolt, Round Head Square Neck .31-18 x 1.00 Grade 5
11	07533600	2	Bumper, Rubber
12	06530400	2	Nut, Spin Lock Flange .312-18
13	59210400	AR	Kit, Right Hand Armrest Assembly
14	59210500	AR	Kit, Left Hand Armrest Assembly
15	59208800	AR	Kit, Back Cushion, Light Grey
16	59208900	AR	Kit, Seat Cushion, Light Grey
17	59208000	AR	Kit, Seat Knobs
18	59208100	AR	Kit, Seat Back
19	59207900	AR	Kit, Seat Slides
20	59207800	AR	Kit, Seat Spring and Saddle

Hood

Model 990100, 101, 102

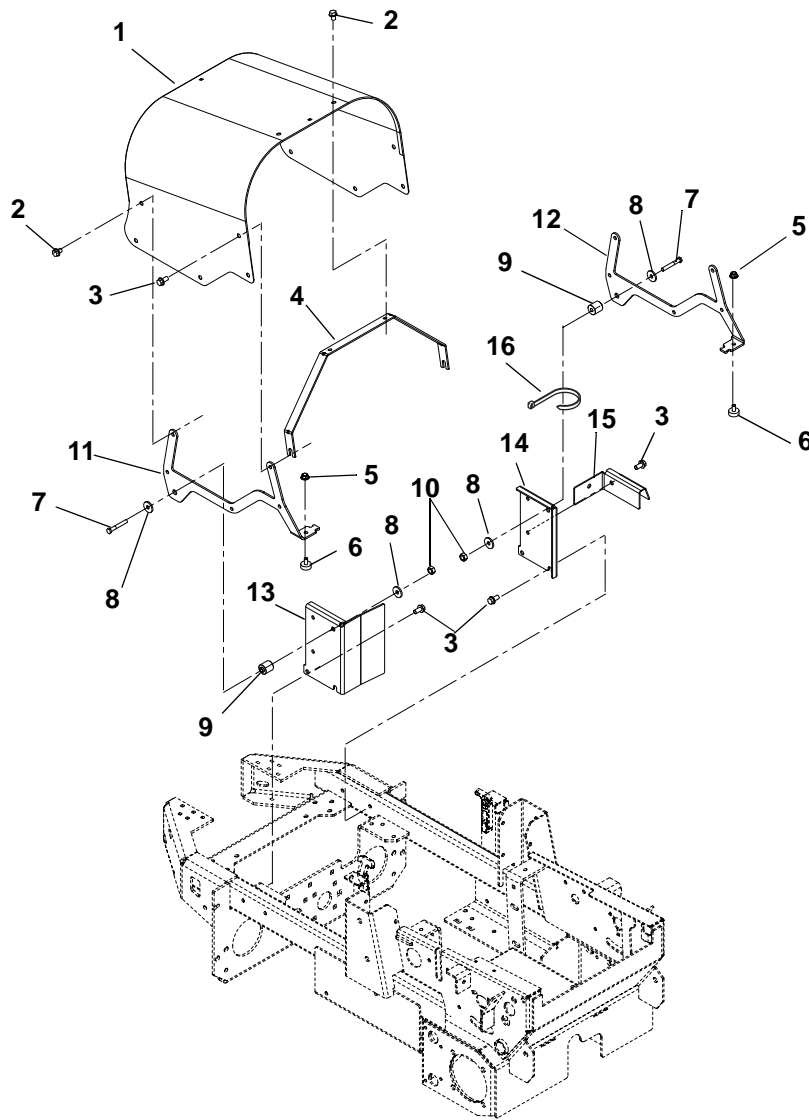

Item	Part No.	Qty.	Description
1	00497353	1	Hood, Outfront Rapid XZ
2	07412900	10	Screw, Tapping .38-16 x .50 Hex Washer Head Thread
3	07415400	5	Screw, Tapping .38-16 x .75 Hex Washer Head Thread
4	00667553	1	Support, Lateral Hood
5	06530400	2	Nut, Spin Lock Flange .312-18
6	07533600	2	Bumper, Rubber
7	05963700	2	Bolt, Hex .31-18 x 2.25 Grade 5
8	06446300	4	Washer, Flat Steel .344 x 1.125 x .135
9	00476300	2	Spacer
10	06529800	2	Nut, Locking-Center .31-18
11	00595653	1	Bracket, Hood Left Hand
12	00595753	1	Bracket, Hood Right Hand
13	00664151	1	Bracket, Hood Support #2
14	00664051	1	Bracket, Hood Support #1
15	00676851	1	Cover, Wire
16	07517300	1	Wire Tie (Clutch wire to wire cover)

NOTES

ENGINE AND CLUTCH

Model 990100, 101, 102

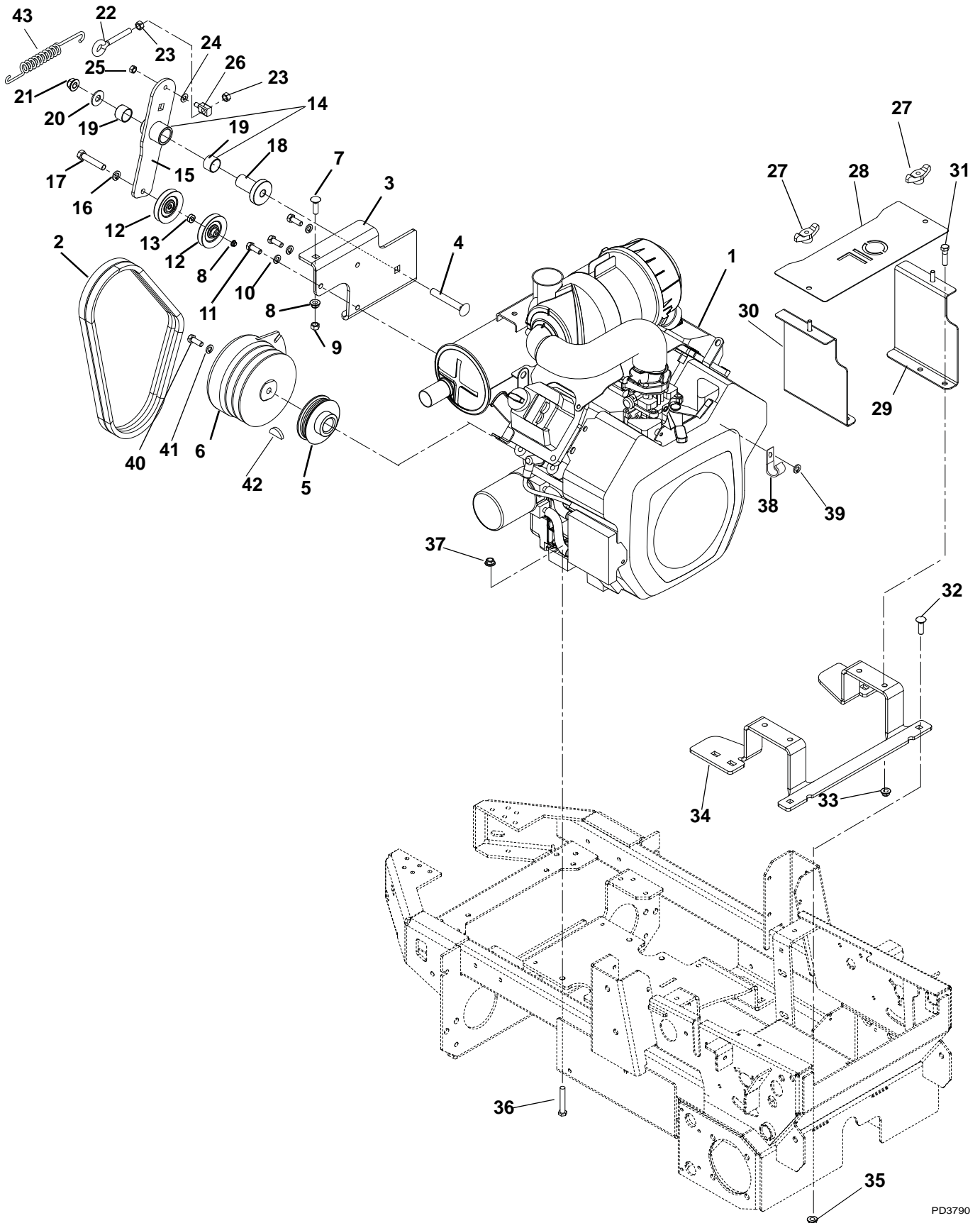

PD3790

ENGINE/CLUTCH

Model 990100, 101, 102

Item	Part No.	Qty.	Description
1	08200132	1	Engine, 27hp Kohler (990100)
	08200118	1	Engine, 25hp Kohler (990101)
	08200145	1	Engine, 30hp Kohler (990102)
2	07200113	1	Belt, B 41.313 Matched Set
3	00667451	1	Bracket, PTO Idler Mounting
4	06225000	1	Bolt, Round Head Square Neck .50-13 x 3.50 Grade 5
5	07300041	1	Sheave, Poly-V
6	00697900	1	Clutch, Warner Double Groove
7	06224100	1	Bolt, Round Head Square Neck .38-16 x 1.25 Grade 5
8	06545500	2	Nut, .38-16 Nyloc Flange
9	06529600	1	Nut, Locking Center .38-16
10	06308800	3	Washer, Locking .38 x .094 Regular
11	05948700	3	Bolt, Hex .38-16 x 1.00 Grade 5
12	07327600	2	V-Idler, 4.00 x .38
13	06400018	1	Washer, .406 x 1.0 x .38THK
14	00652700	1	Assembly, Idler Pivot Assembly (includes items 15 and 19)
15	00652300	1	Weldment, PTO Idler Pivot Arm (OFM)
16	06435900	1	Washer, Flat Steel .438 x 1.00 x .083
17	05957800	1	Bolt, Hex .38-16 x 3.00 Grade 5
18	07000031	1	Bearing, Pedestal
19	05435800	2	Bearing, 1.00 x 1.12 x .75
20	06430200	1	Washer, Flat Steel .531 x 1.250 x .100
21	06500010	1	Nut, .50-13 Nyloc Flange
22	07030000	1	Bolt, Eye .375-16 x 2.50
23	06529400	2	Nut, Hex .38-16
24	06437200	1	Washer, Flat Steel .344 x .688 x .065
25	06529800	1	Nut, Locking Center .31-18
26	09267300	1	Pin, Pivot
27	07531700	2	Knob, Wing
28	00865151	1	Shroud, Cooling
29	00866951	1	Bracket, Tank Shroud Left Hand
30	00867051	1	Bracket, Tank Shroud Right Hand
31	05957900	4	Bolt, Hex .38-16 x 1.50 Grade 5
32	06223600	2	Bolt, Round Head Square Neck .38-16 x 1.00 Grade 5
33	06545500	4	Nut, .38-16 Nyloc Flange
34	00682451	1	Mount, Hydraulic Tank
35	06545500	2	Nut, .38-16 Nyloc Flange
36	05962900	4	Bolt, Hex .38-16 x 2.25 Grade 5
37	06542000	4	Nut, Locking Top Flange .38-16
38	06916000	2	J-Clamp
39	06437300	2	Washer, Flat Steel .281 x .62 x .065
40	05900040	1	Bolt, Hex .44-20 x 2.25 Grade 5 EP80
41	06309300	1	Washer, Locking .44 x .109 Regular
42	06603400	1	Key
43	08321200	1	Spring, Tension .135X.69X5.75

FUEL TANKS AND HOSES

Model 990100, 101, 102

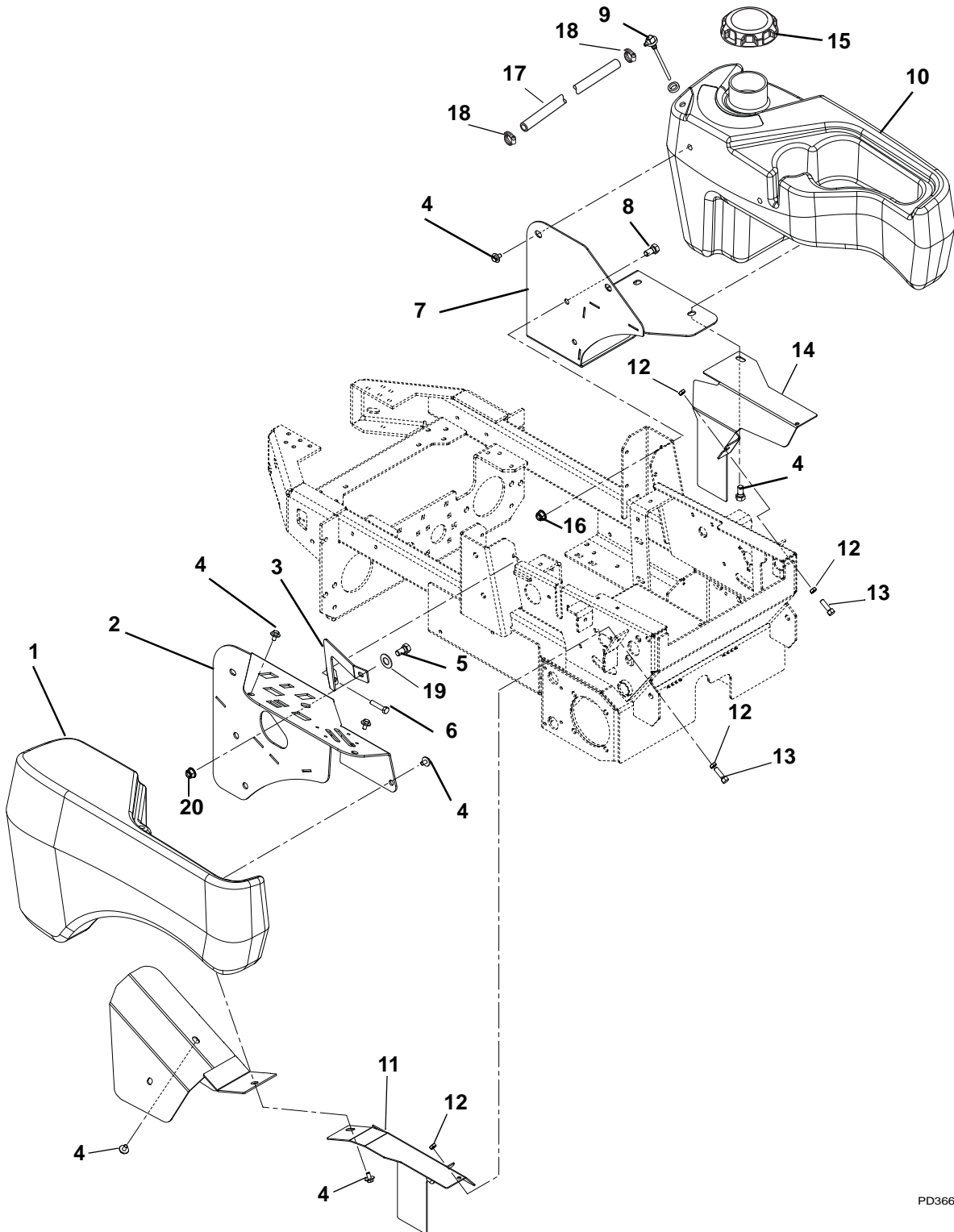

PD3661

FUEL TANKS AND HOSES

Model 990100, 101, 102

Item	Part No.	Qty.	Description
1	00497400	1	Fender, Right Hand
2	00473951	1	Weldment, Control Panel
3	00616851	1	Stiffener, Fender
4	07000018	12	Bolt, SEMS .31-18 x .62
5	05959400	1	Bolt, Hex .38-16 x .75 Grade 5
6	07412900	1	Screw, Tapping .38-16 x .50 Hex Washer Head Thread Rolling
7	00588451	1	Weldment, Fuel Tank Bracket (Outfront)
8	05947100	2	Bolt, Hex .50-13 x 1.00 Grade 5
9	00592600	1	Assembly, Fuel Line and Fitting
10	00497500	1	Tank, Fuel Left Hand Outfront
11	00672751	1	Cover, Tire Right Hand
12	06535900	4	Nut, Hex Jam .375-16
13	05958000	2	Bolt, Hex .38-16 x 1.25 Grade 5
14	00672651	1	Cover, Tire Left Hand
15	00273700	1	Cap, Fuel
16	06500010	4	Nut, .50-13 Nyloc Flange
17	00924300	33"	Gas Line, Bulk 1/4" I.D.
18	06939100	2	Clamp, Hose Wire .490/.510 x .116
19	06435700	1	Washer, Flat Steel .38 x .875 x .083
20	06534900	1	Nut, Flange .375-16

HYDROSTATIC PUMPS AND IDLERS

Model 990100, 101, 102

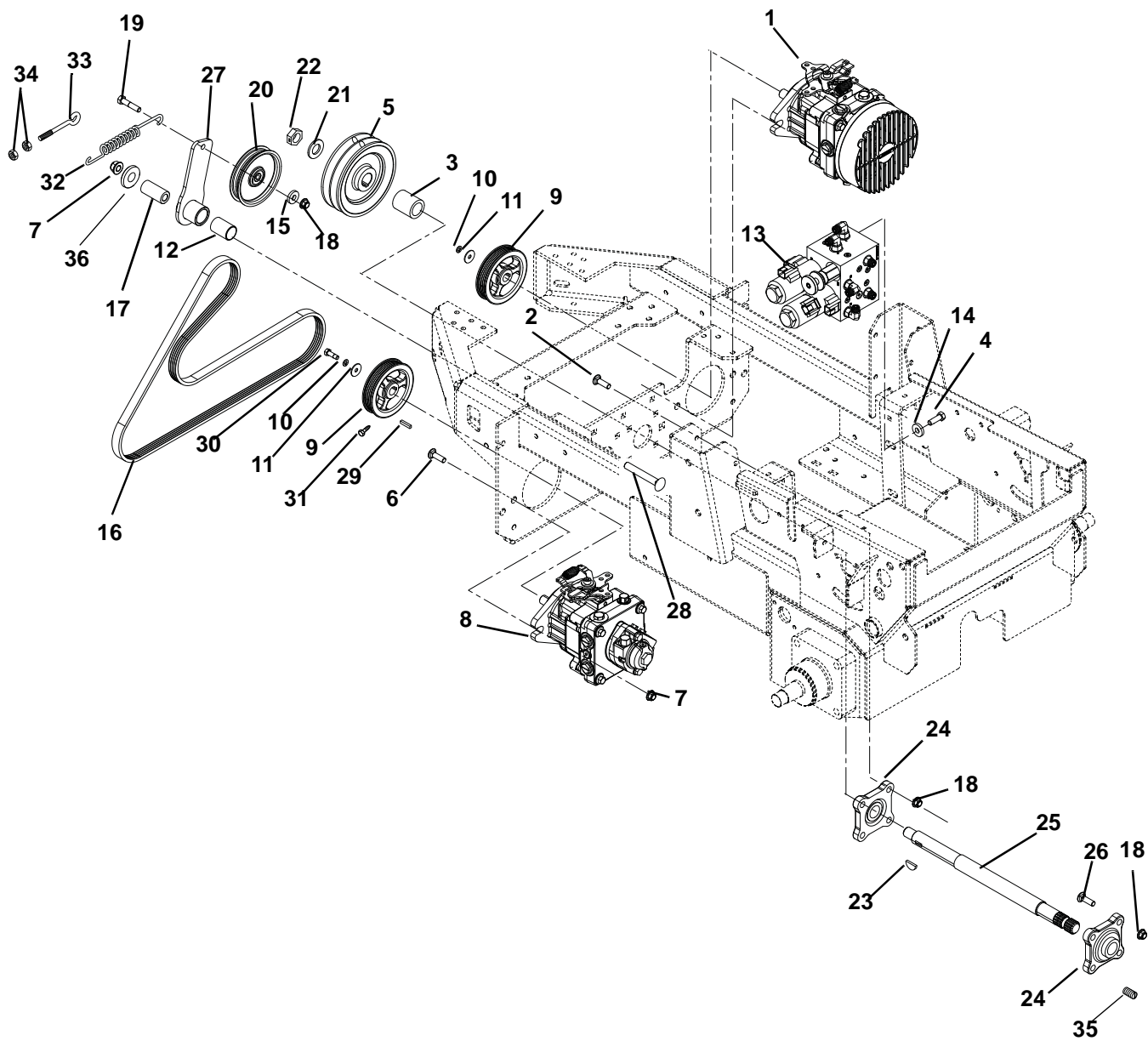

PD3671

HYDROSTATIC PUMPS & IDLERS

Model 990100, 101, 102

Item	Part No.	Qty.	Description
1	00587200	1	Pump, Hydraulic BDP-21L Left Hand Rapid XZ
2	06224100	4	Bolt, Round Head Square Neck .38-16 x 1.25 Grade 5
3	00677100	1	Spacer, 1.0ID x 1.5OD x 1.81 Lining
4	05946900	2	Bolt, Hex .31-18X1.00 Grade 5
5	07300034	1	Sheave, Double 1"ID x 6.26"OD
6	06223100	4	Bolt, Round Head Square Neck .50-13 x 1.50 Grade 5
7	06500010	6	Nut, .50-13 Nyloc Flange
8	00587300	1	Pump, Hydraulic BDP-21L Right Hand Rapid XZ
9	07300037	2	Sheave, Poly V .671 x 4.125
10	06308400	2	Washer, Locking .25 x .06
11	06426600	2	Washer, Flat Steel .281 x 1.000 x .063
12	05500123	1	Bearing, 1.00 x 1.125 x 1.936
13	00608100	1	Valve, 2 Spool Mainifold Block
14	06446300	2	Washer, Flat Steel .344 x 1.125 x .135
15	06444000	1	Washer, Flat Steel .406 x 1.00 x .188
16	07243700	1	Belt, Poly-V 69.39 (5 RIBS)
17	01581700	1	Bushing, Spacer .5058.500 x .999/.906 x 2.05/2.03
18	06545500	10	Nut, Nyloc Flange .38-16
19	05962900	1	Bolt, Hex .38-16 x 2.25 Grade 5
20	07312500	1	Idler, Flat 4.00 x .38
21	06439000	1	Washer, Flat-Steel .812 x 1.50 x .135
22	06536900	1	Nut, Jam Center Lock .75-16
23	06601200	1	Key, Woodruff .25 x .750 x .313 SAE91
24	05400015	2	Bearing, 1" ID 4 Bolt Trash Seal
25	00887700	1	Shaft, PTO Jack Shaft Rapid XZ
26	05958000	4	Bolt, Hex .38-16 x 1.25 Grade 5
27	00349100	1	Assembly, Idler Pivot Arm
28	06225000	1	Bolt, Round Head Square Neck .50-13 x 3.50 Grade 5
29	06611300	2	Key, Square 5 x 5 x 30MM Plain
30	05975900	2	Bolt, Hex M6-1 x 16
31	05980100	2	Screw, Socket Head .25-20 x .50 PH and Oil
32	08321200	1	Spring, Tension .135 x .69 x 5.75 Weldment 150
33	07030000	1	Bolt, Eye .375-16 x 2.50
34	06529400	2	Nut, Hex .38-16
35	06000003	1	Screw, Set .25-28 x .38
36	06436400	1	Washer, Flat Steel .511 x 1.44 x .125

REAR AXLE AND WEIGHTS

Model 990100, 101, 102

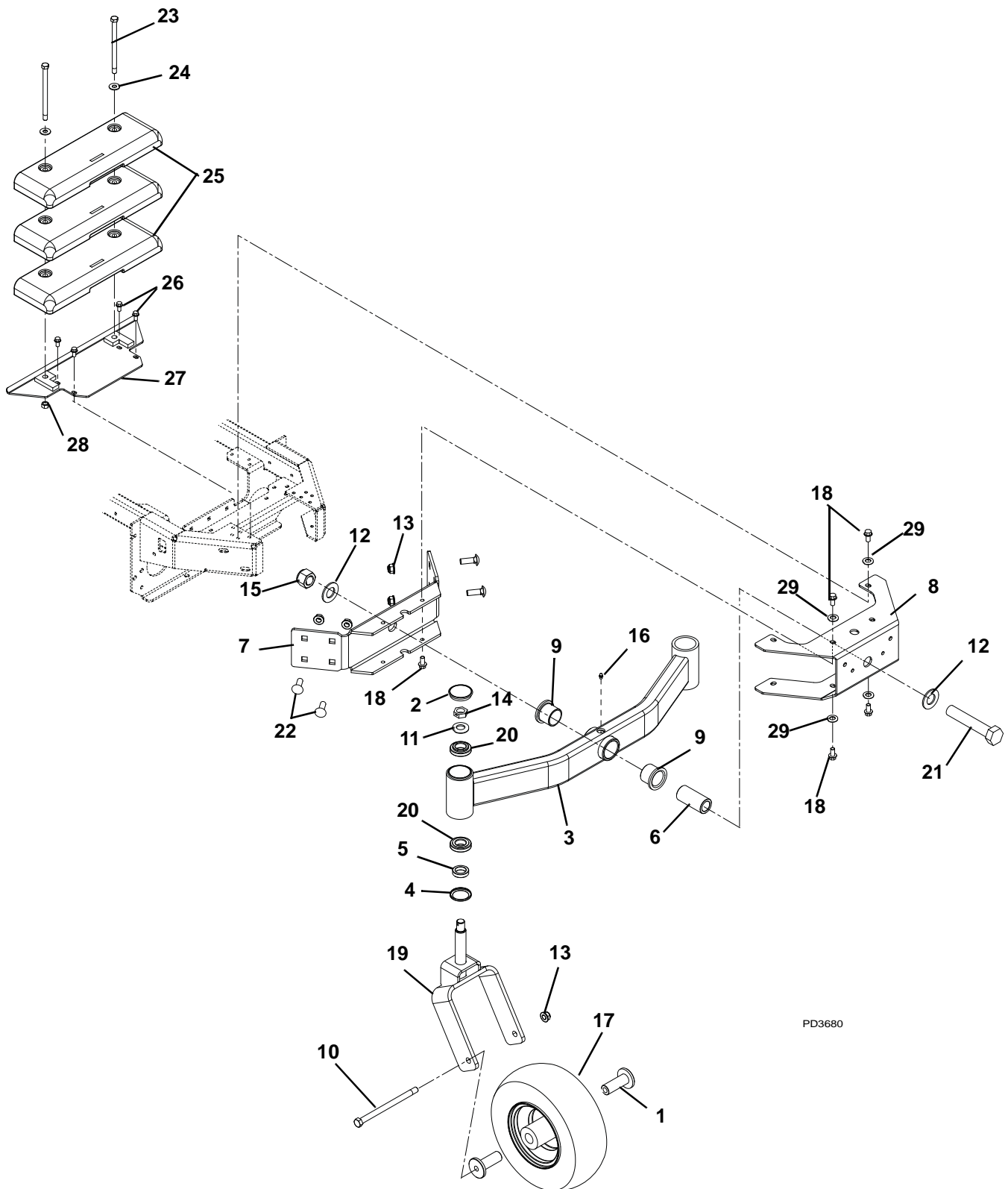

PD3680

REAR AXLE AND WEIGHTS

Model 990100, 101, 102

Item	Part No.	Qty.	Description
1	00675300	4	Spacer, Wheel
2	00456800	2	Cap, Dust
3	00475051	1	Weldment, Rear Axle
4	00531400	2	Bearing Seal 1.5 x 2 x .18
5	00531500	2	Spacer, 1.005 x 1.5075 x .375
6	00607900	1	Spacer, 1 x 1.50 x 3.16"LG
7	00613300	1	Weldment, Rear Axle Mounting Plate
8	00613400	1	Cover, Dual Rear Axle
9	05517600	2	Bushing, Flange 1.514 x 1.756 x 1.688 x 2.250 Nylon
10	05978200	2	Bolt, Hex .50-13 x 7.50 Grade 5
11	06439000	2	Washer, Flat Steel .812 x 1.50 x .135
12	06443000	2	Washer, Flat Steel 1.062 x 2.0 x .134
13	06500010	6	Nut, Nyloc Flange .50-13
14	06536900	2	Nut, Jam Center Lock .75-16
15	06500022	1	Nut, Locking Nylon 1.0-8
16	07012600	1	Fitting, Lube .25-28 x .256
17	07100206	2	Tire/Wheel Assembly 13 x 5-6
18	05959400	4	Bolt, Hex .38-16 x .75 Grade 5
19	00490251	2	Fork, Front
20	05407000	4	Bearing, Cup 1.980 x .420
	69000300	4	Bearing, Cone with Grease
21	05900104	1	Bolt, Hex 1.0-8 x 5.50 Grade 5
22	06223100	4	Bolt, Round Head Square Neck .50-13 x 1.50 Grade 5
23	05978200	2	Bolt, Hex .50-13 x 7.50 Grade 5
24	06430200	2	Washer, Flat Steel .531 x 1.250 x .100
25	00172000	3	Weight, Cast Iron
26	07415400	4	Screw, Tapping .38-16 x .75 Hex Washer Head Thread Rolling
27	00595451	1	Bracket, Weight (Outfron)
28	06536300	2	Nut, Locking Center .50-13
29	06435700	4	Washer, Flat Steel .38 x .875 x .083

BRAKE LINKAGE

Model 990100, 101, 102

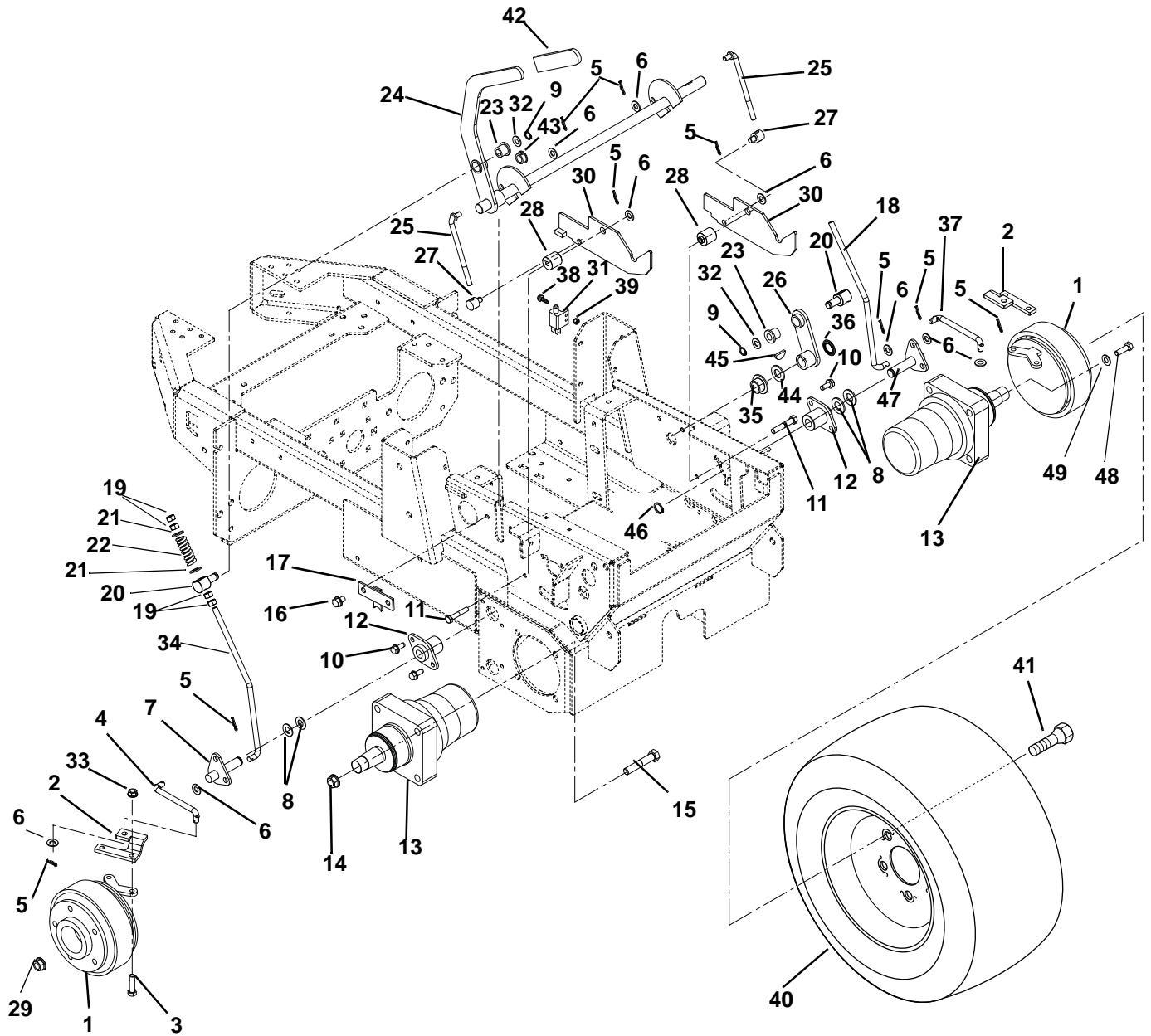

BRAKE LINKAGE

Model 990100, 101, 102

Item	Part No.	Qty.	Description
1	00602500	2	Assembly, Brake
2	00668251	2	Extension, Brake
3	05946900	4	Bolt, Hex .31-18 x 1.00 Grade 5
4	00619400	1	Rod, Parking Brake Set Right Hand
5	06714800	10	Pin, Hair, ENDRIES #25
6	06436200	10	Washer, Flat Steel .406 x .812 x .065
7	00619500	1	Weldment, Pivot (SN 000101 - 000499)
	00962800	1	Weldment, Pivot RH (SN 000500 and up)
8	06430300	4	Washer, Flat Steel .656 x 1.250 x .100
9	05717100	2	Ring, Retaining External .500 x .050
10	07414400	4	Screw, Tapping .31-18 x .75 Hex Washer Head Thread
11	05957400	2	Bolt, Hex .31-18X1.75 Grade 5
12	05534700	2	Bushing, Flanged
13	00452600	2	Motor, Wheel TG 0280
14	06500010	8	Nut, Nyloc Flange .50-13
15	07067200	8	Bolt, Wheel Motor .50-13 x 2.75
16	07412900	2	Screw, Tapping .38-16 x .50 Hex Washer Head Thread Rolling
17	00497851	1	Weldment, Parking Brake Hold Down
18	00604800	1	Rod, O.C. Left Hand Brake
19	06529400	8	Nut, Hex .38-16
20	00698600	2	Trunnion, Pivot .38
21	06435700	4	Washer, Flat Steel .38 x .875 x .083 (SN 000101 - 499)
	05500041	4	Bushing, Flange .39 x .53 x .38 x 1.00 (SN 000500 and up)
22	08300034	2	Spring, Compression (SN 000101 - 499)
	08300105	2	Spring, Compression (SN 000500 and up)
23	05503100	2	Bushing, Flange .500 x .750 x .750 x 1.000 Bracket
24	00491900	1	Weldment, Parking Brake
25	00679500	2	Rod, Brake Link .375-24 UNF
26	00504900	1	Weldment, Brake Lever - Left Hand
27	00679600	2	Trunnion, .375-24 UNF
28	00476300	2	Spacer, Neutral Latch
29	06536900	2	Nut, Jam Center Lock .75-16
30	00596500	2	Latch, Brake Lock
31	03606600	1	Switch, Double Pole N.O./N.O.
32	06418100	2	Washer, Hardened Steel THR.515 x .97 x .062
33	06545400	8	Nut, .31-18 Nyloc Flange
34	00594200	1	Rod, O.C. Right Hand Brake
35	05518400	1	Bushing, Flange .762 x 1.0 x .580 x 1.48 Nylon
36	07000036	1	Push Nut, .745 Shaft
37	00616900	1	Rod, Parking Brake Set Left Hand
38	06116900	2	Screw, Machine 10-24 x .75 Hex Washer Head
39	06536000	2	Nut, Locking Nylon 10-24 with Insert
40	07157500	2	Tire/Wheel Assembly 24 x 12-12 (990100, 101)
	07100329	1	Right Hand Bar Tire, 24 x 12-12 (990102)
	07100328	1	Left Hand Bar Tire, 24 x 12-12 (990102)
41	07067700	10	Bolt, Lug Grade 8; .50-20 UNF x 1.38 LG; 60 Degree
42	07523000	1	Grip, Handle
43	05500112	1	Bushing, Split .75 x .81 x .20 THK
44	06413400	1	Washer, Hardened Thrust .758 x 1.23 x .031
45	06608700	1	Key, Woodruff .19 x .75 HRD#9
46	05709200	2	Ring, Retaining External .625 x .050
47	00619500	1	Weldment, Pivot (SN 000101 - 000499)
	00962700	1	Weldment, Pivot LH (SN 000500 and up)
48	05981600	8	Bolt, Hex .31-18 x 1.50 Grade 8 EP30
49	06308600	8	Washer, Lock .31 x .078 Regular

STEERING LEVERS & LINKAGES

Model 990100, 101, 102

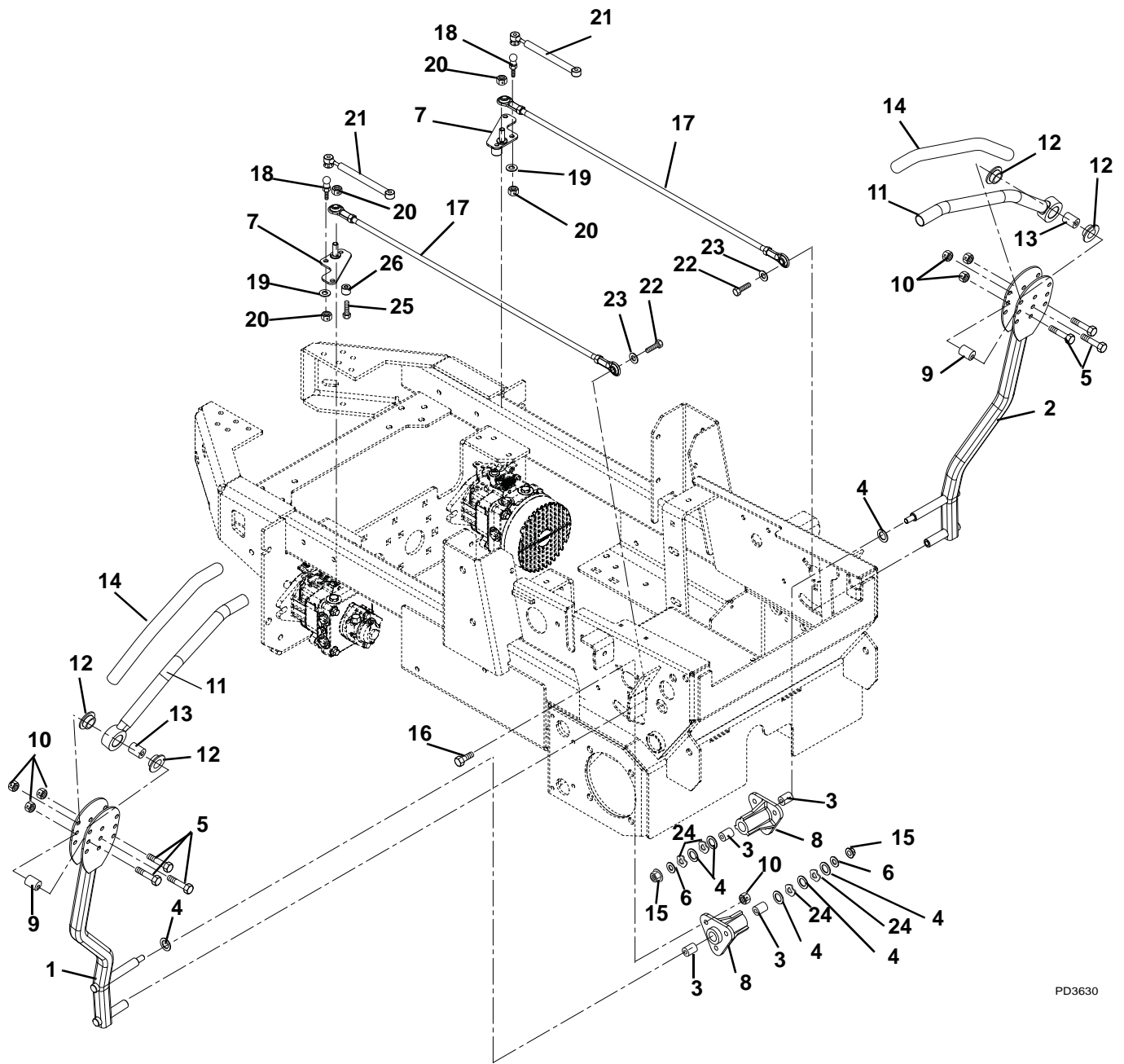

PD3630

STEERING LEVERS & LINKAGES

Model 990100, 101, 102

Item	Part No.	Qty.	Description
1	00585051	1	Weldment, Bent Steering Arm - Right Hand
2	00472951	1	Weldment, Bent Steering Arm - Left Hand
3	05436800	4	Bushing .625 x .75 x .50
4	06436100	6	Washer, Flat Steel .630 x 1.005 x .062
5	05957400	6	Bolt, Hex .31-18 x 1.75 Grade 5
6	06435900	2	Washer, Flat Steel .438 x 1.00 x .083
7	00492400	2	Weldment, Damper, Steering
8	09294600	2	Housing, Bushing
9	09235700	4	Eccentric
10	06545400	12	Nut, Nyloc Flange .31-18
11	09235500	1	Handle, Left Hand
	09235600	1	Handle, Right Hand
12	05525200	4	Bushing, Flange Nylon .762 x 1.48 x .44
13	09235400	2	Spacer
14	00675200	2	Grip, Handlebar
15	06545500	2	Nut, Nyloc Flange .38-16
16	06216100	6	Bolt, Round Head Square Neck .31-18 x 1.00 Grade 5
17	00587500	2	Assembly, Steering Rod .38ROD x 30.43LG
18	03652200	2	Stud, Ball
19	06308600	2	Washer, Locking .31 x .078 Regular
20	06545400	4	Nut, .31-18 Nyloc Flange
21	09273400	2	Damper, Control
22	05900013	2	Bolt, Hex .38-16 x 1.00 EP30
23	06436200	2	Washer, Flat Steel .406 x .812 x .065
24	03704900	4	Wave Washer .640 x .875 x .125
25	05947500	2	Bolt, Hex .31-18 x 1.25 Grade 5
26	03101900	2	Spacer .318 x .430 x .375

CONTROL PANEL

Model 990100, 101, 102

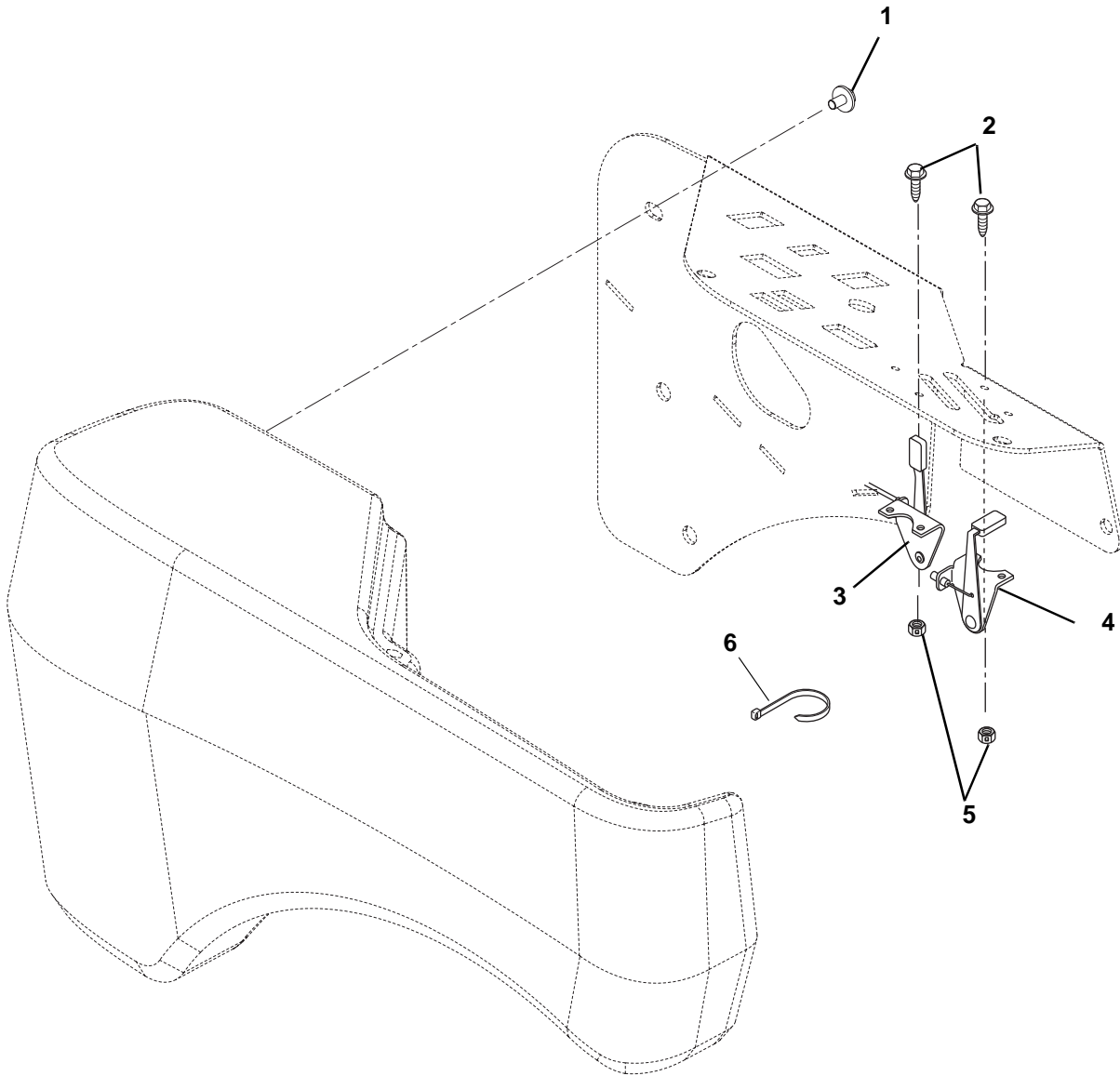

PD3650

Item	Part No.	Qty.	Description
1	07000018	7	Bolt, SEMS .31-18 x .62
2	06116700	4	Screw, Machine 10-24 x .50 Hex Washer Head
3	06900040	1	Cable, Kohler Throttle
4	06900041	1	Cable, Kohler Choke
5	06536000	4	Nut, Locking Nylon 10-24 With Insert
6	07517300	1	Cable Tie

NOTES

WEIGHT TRANSFER

Model 990100, 101, 102

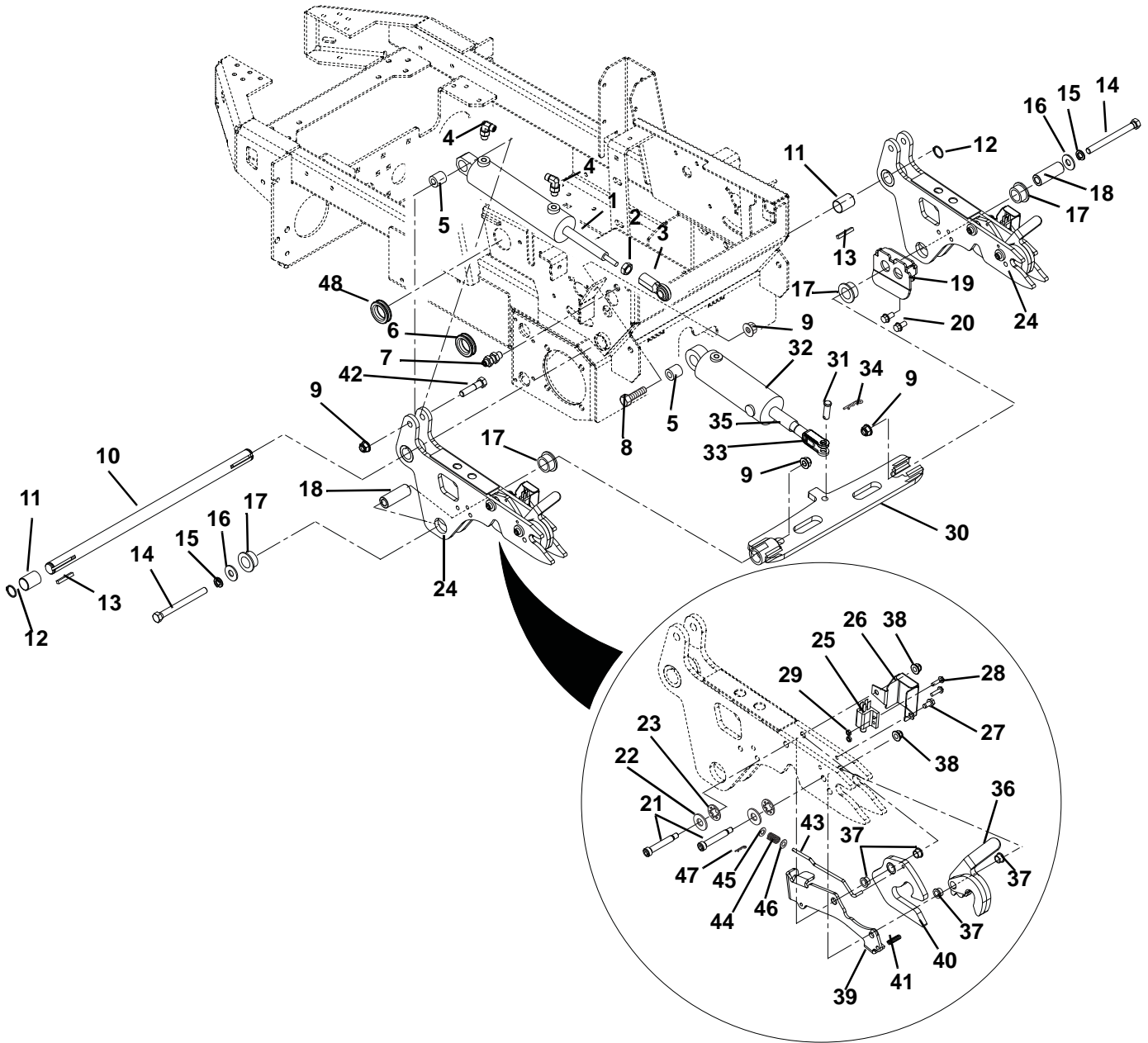

WEIGHT TRANSFER

Model 990100, 101, 102

Item	Part No.	Qty.	Description
1	00585100	1	Cylinder, Hydraulic Deck Lift
2	06539600	1	Nut, Jam .625-18
3	09221600	1	Rod End, 5/8 Right Hand - Female
4	07000045	2	Adapter, Hydraulic Fitting 90 M4F-M6O
5	09215200	2	Bushing, .516 x 1.000 x 1.050
6	07536800	1	Grommet, 1.25
7	07000044	1	Fitting, Hydraulic Bulkhead M4F-M4F
8	05961000	1	Bolt, Hex .50-13 x 2.25 Grade 5
9	06500010	4	Nut, .50-13 Nyloc Flange
10	00606500	1	Shaft, Main Arm Pivot
11	05500034	2	Bushing, 1.00 ID x 1.125 OD x 1.50
12	05707300	2	Ring, Retaining External 1.00 x .078
13	06601800	2	Key, Straight .25 x 1.75 x .25
14	05964100	2	Bolt, Hex .50-13 x 5.50 Grade 5
15	06307300	2	Washer, Locking .50 x .125 Regular
16	06445000	2	Washer, Flat Steel .515 x 1.625 x .250
17	05520100	4	Bushing, Flange 1.020 x 1.385 x .75 x 1.75 Nylon
18	00606600	2	Spacer, 1.00 x .562 x 2.720
19	00678851	2	Weldment, Stop, Deck Block
20	07415400	4	Screw, Tapping .38-16 x .75 Hex Washer Head Thread Rolling
21	07000105	4	Bolt, Socket Head Shield .31 x 18 x 2-.38
22	06444000	4	Washer, Flat Steel .406 x .812 x .065
23	06300002	4	Washer, Lock Internal .375
24	00601151	2	Weldment, Lift Arm
25	03657100	1	Switch, Single Pole N.O.
26	00679451	1	Guard, PTO Safety Switch Mount
27	07411600	1	Screw, Tapping .250-20 x .37 Hex Washer Head
28	06116900	2	Screw, Machine 10-24 x .75 Hex Washer Head
29	06576000	2	Nut, Locking Nylon 10-24 with Insert
30	00867100	1	Weldment, Weight Transfer Bar
31	06814700	1	Pin, Clevis .50 x 1.33
32	00616700	1	Cylinder, Hydraulic 2.5 x 4.0
33	08797200	1	Yoke, .50-20 x 3.00
34	06714900	1	Pin, Hair, External- #16
35	07000107	1	Stud .5-20 x 2.0 Grade 8
36	00608253	2	Latch Lever
37	05503600	8	Bushing, Flange .372 x .500 x .312 x .625 NY
38	06545400	4	Nut, .31-18 Nyloc Flange
39	00662751	2	Latch Support Plate
40	00676200	2	Latch, TILT
41	08300032	2	Spring, Lever Retention
42	05966600	1	Bolt, Hex .50-13 x 2.50 Grade 5
43	00676400	2	Rod, Latch Tension
44	08300028	2	Spring, Compression
45	06437300	2	Washer, Flat Steel .281 x .62 x .065
46	06435700	2	Washer, Flat Steel .38 x .875 x .083
47	06701900	2	Pin, Hair Internal .06 x .18 x .77
48	07500017	1	Grommet, 2.00"

HYDRAULIC TANK, FILTER, PUMPS, & HOSES

Model 990100, 101, 102

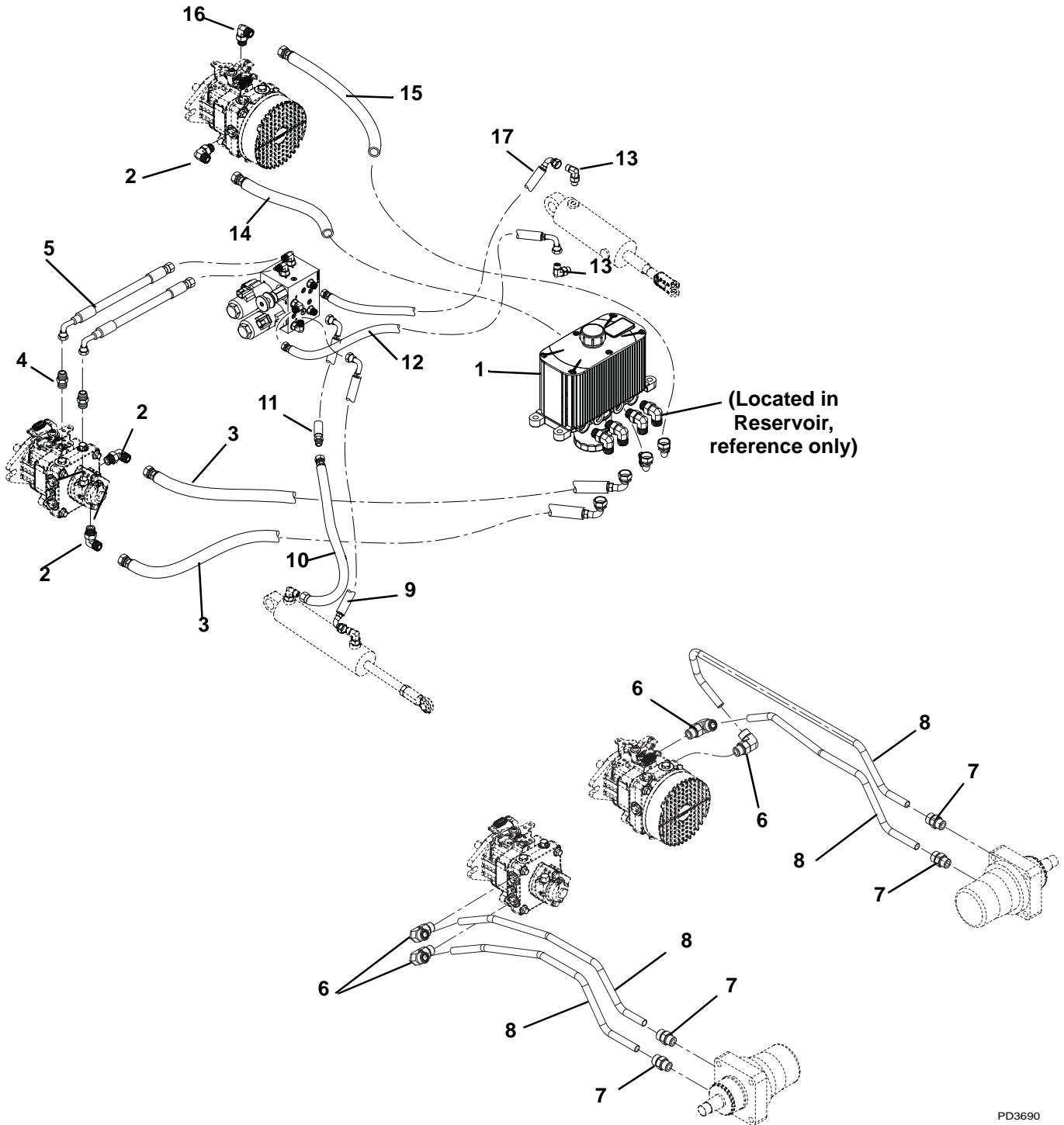

PD3690

HYDRAULIC TANK, FILTER, PUMPS, & HOSES

Model 990100, 101, 102

Item	Part No.	Qty.	Description
1	00585500	1	Tank, Hydraulic Reservoir/Filter
2	07069600	3	Fitting, Hydraulic 90 Elbow M8F-M8O 8 C5OLO-Steel
3	00601700	2	Hose, Hydraulic .50-15-0K F08F0-F08F9
4	07064100	2	Fitting, Hydraulic
5	01967900	2	Hose, Hydraulic
6	07000043	4	Fitting, Hydraulic 90 M10F-M8O
7	07000042	4	Fitting, Hydraulic Straight M10O-M10F
8	00669000	4	Hose, Hydraulic .50-25-2K F10F0-F10F0
9	00608900	1	Hose, Hydraulic .25-39-2K F04F0-F04F0
10	00609000	1	Hose, Hydraulic .25-16-2K F04F0-F04F9
11	00608700	1	Hose, Hydraulic .25-20-2K F04F9-F04F9
12	00608600	1	Hose, Hydraulic .25-21-2K F04F0-F04F9
13	07000045	2	Adapter, Hydraulic Fitting 90 M4F-M6O 4-6 C5OLO
14	00959700	1	Hose, Hydraulic .5-17.25-0K F8F9-F8F9
15	00960100	1	Hose, Hydraulic .5-17.25-0K F8F9-F8F9
16	07059900	1	Adapter, Face Seal 8 x 8 .50 O-Ring
17	00698400	1	Hose, Hydraulic .25-16-2K F04F9-F04F0

HYDRAULIC ROUTING DIAGRAM

Model 990100, 101, 102

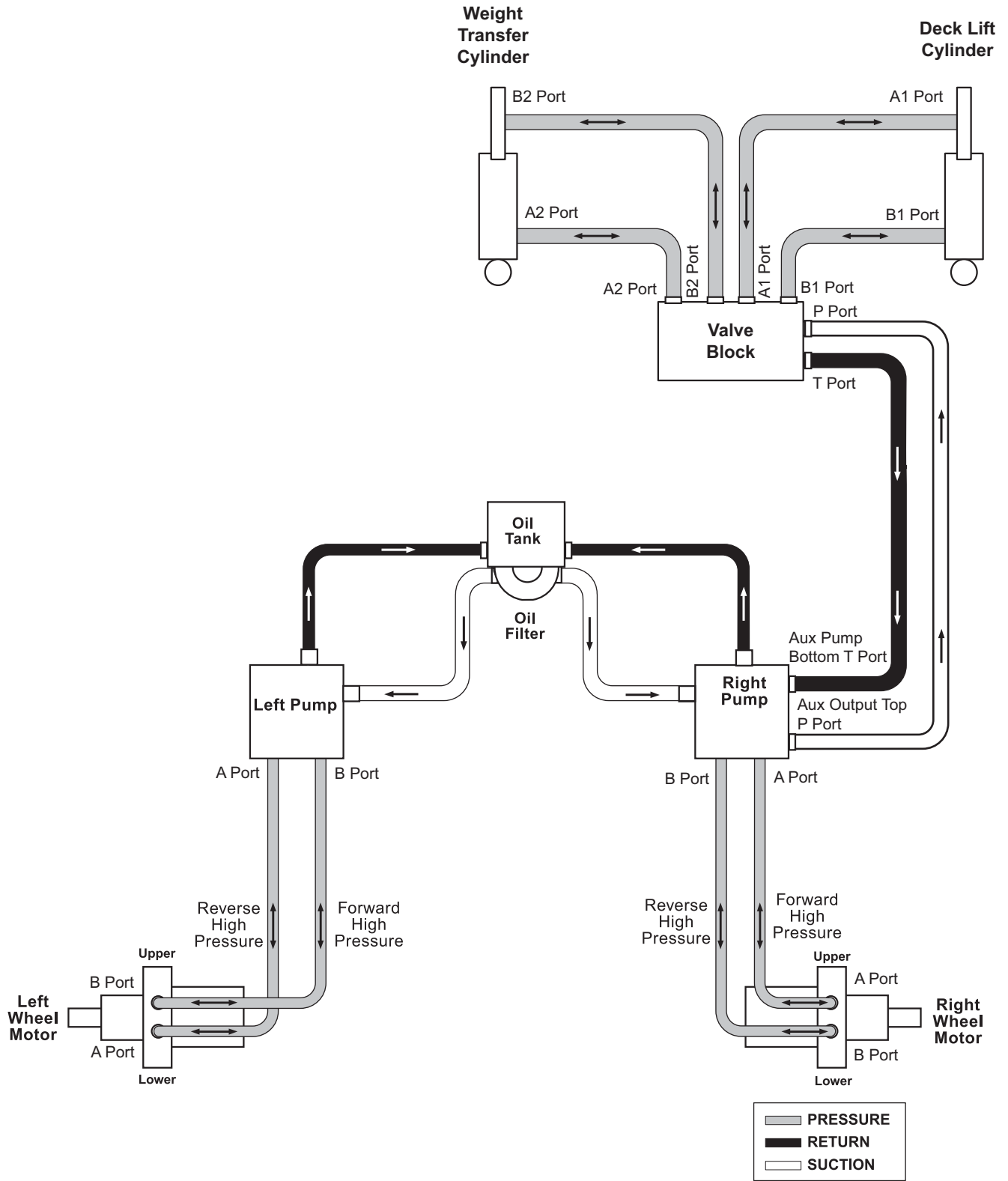

PD0740

NOTES

ELECTRICAL SYSTEM

Model 990100, 101, 102

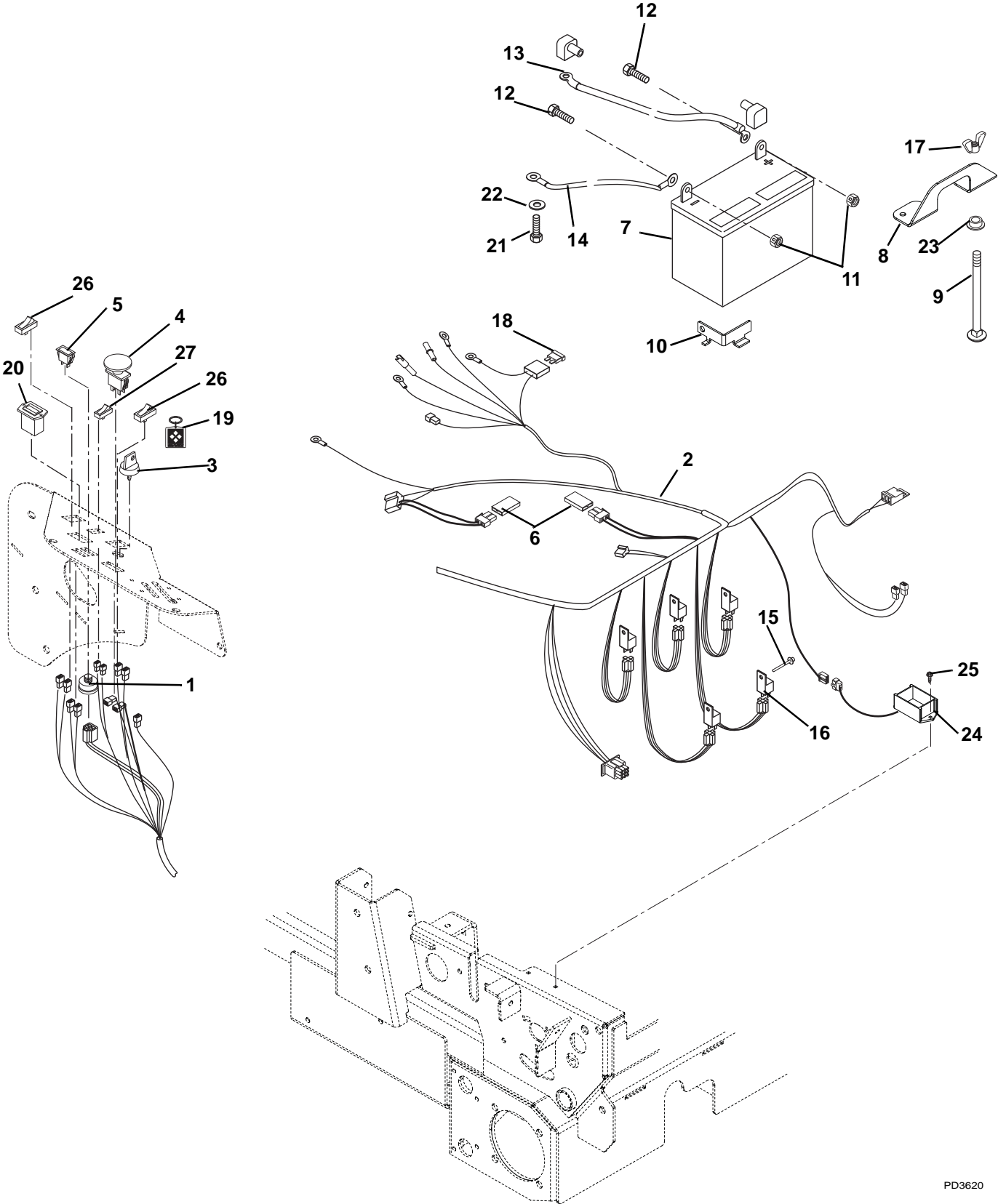

PD3620

ELECTRICAL SYSTEM

Model 990100, 101, 102

Item	Part No.	Qty.	Description
1	00464000	1	Key Switch
2	00492000	1	Harness, Rapid XD
3	09287000	1	Key with Shield
4	01545600	1	Switch, Clutch With Retainer Ring
5	08841200	1	Light, Indicator
6	09293500	2	Diode, Connector Shell
7	01554800	1	Battery
8	00428151	1	Hold Down, Battery
9	06226400	2	Bolt, Round Head Square Neck .25-20 x 7.50
10	00616451	2	Bracket, Battery Position
11	06500012	2	Nut, .25-20 Nyloc Flange
12	05946800	2	Bolt, Hex .25-20 x .75 Grade 5
13	00605900	1	Cable, Positive
14	09222700	1	Cable, Negative Battery 35.0" LG
15	06800004	5	Rivet, Nylon
16	00432100	AR	Relay, Sealed with diode (Included with Harness)
17	06537500	2	Nut, Locking Wing .25-20
18	00524600	AR	Fuse, 30 Amp (Included with Harness)
19	00457400	1	Key Chain
20	00456600	1	Hour Meter
21	05956300	1	Bolt, Hex M8 x 1.25 x 16
22	06308600	1	Washer, Locking .31 x .078 Regular
23	07027600	2	Nut, Push .25 x .50 O.D.
24	00678300	1	Assembly, Weight Transfer Angle Sensor
25	07411900	2	Screw, Tapping 12-24 x .50 Hex Washer Head Thread Rolling
26	00652100	2	Switch, Double Pole Double Throw
27	08973300	1	Switch, 2 Pole/Rocker

CONTINUITY DIAGRAM

Model 990100, 101, 102

The diagrams below show the various states of connection for electrical components.

The solid lines on switches show continuity.

NOTE: All switches are viewed from the rear.

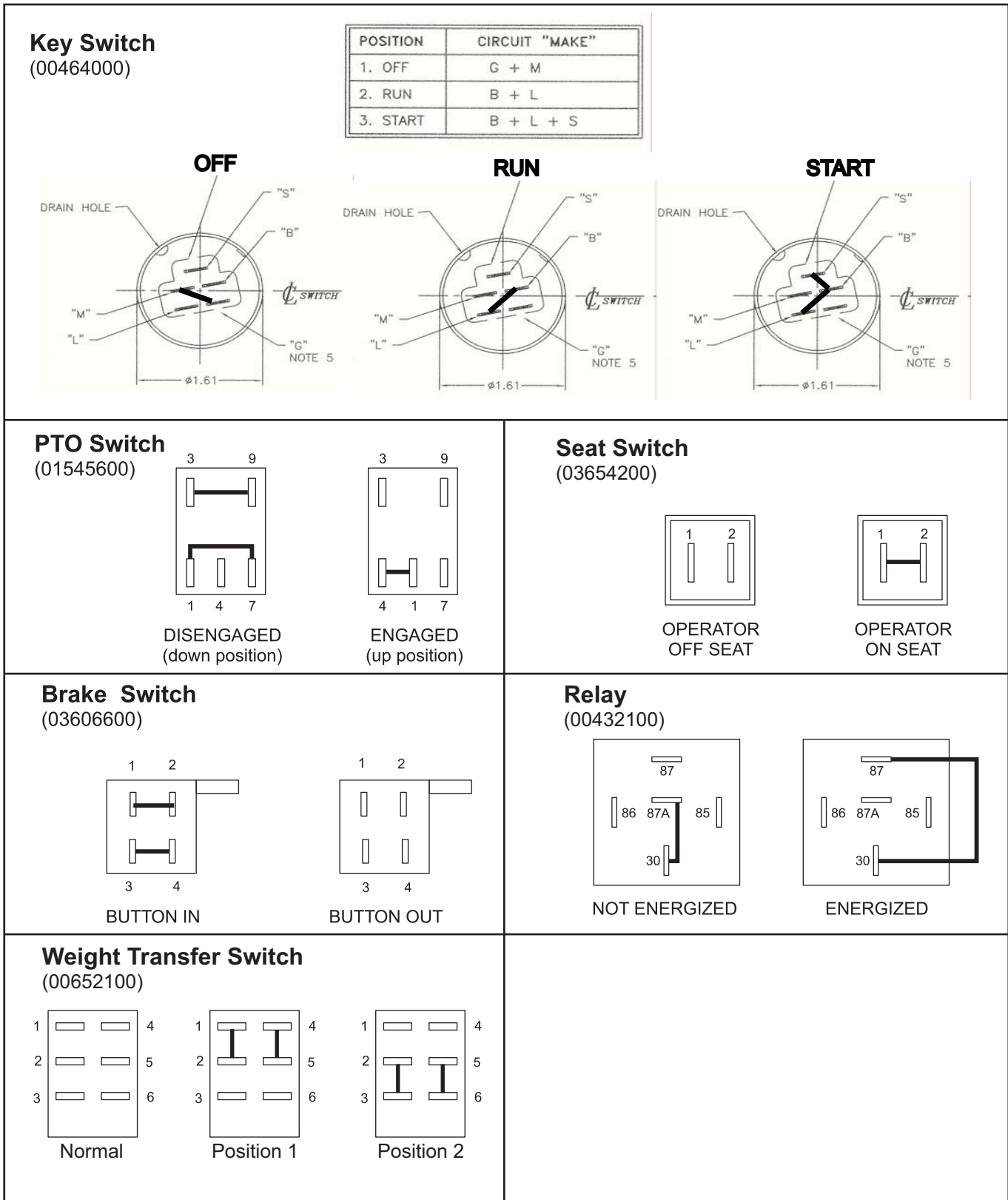

WIRING DIAGRAM

Model 990100, 101, 102

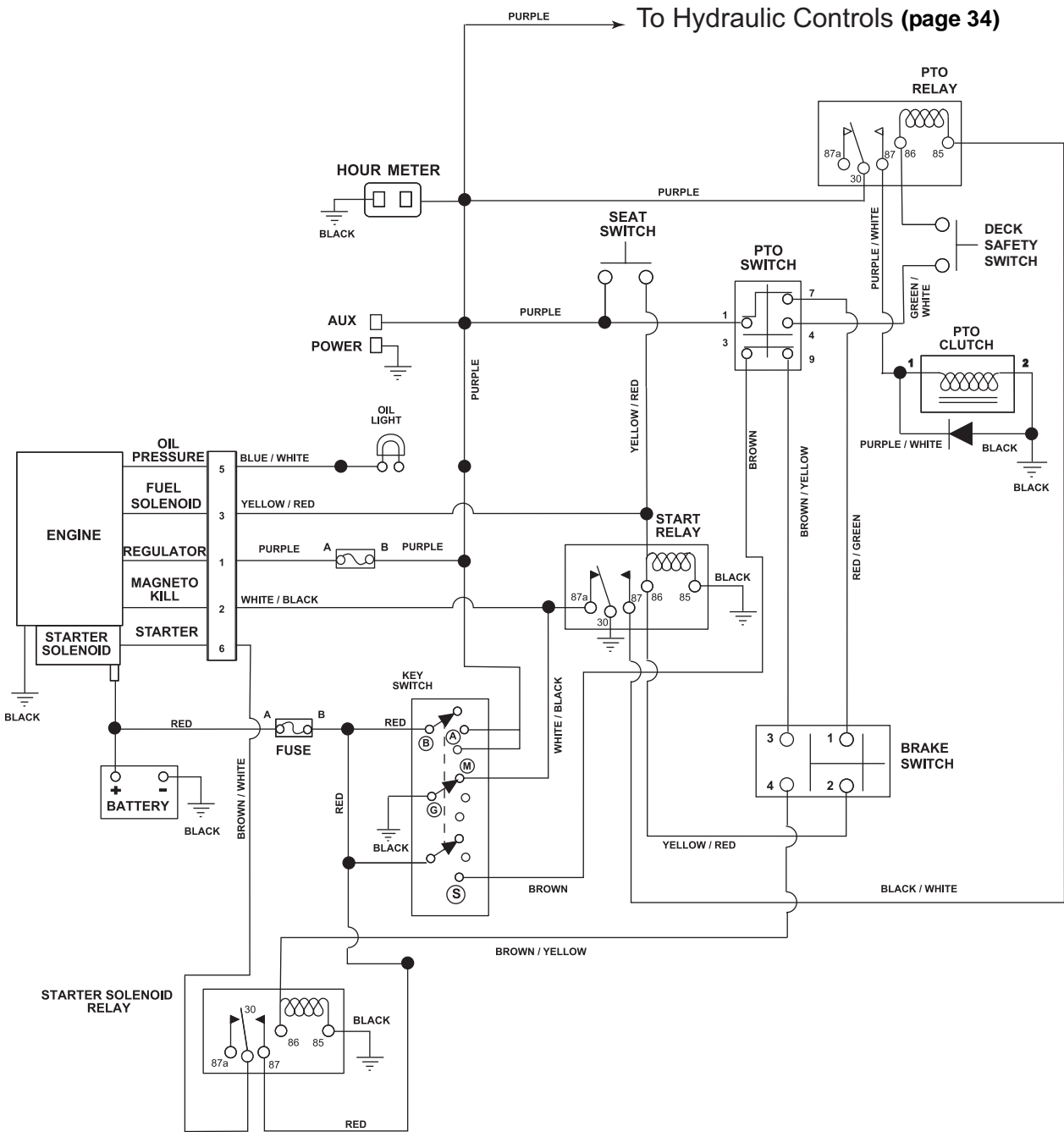

PD2413

WIRING DIAGRAMS

Model 990100, 101, 102

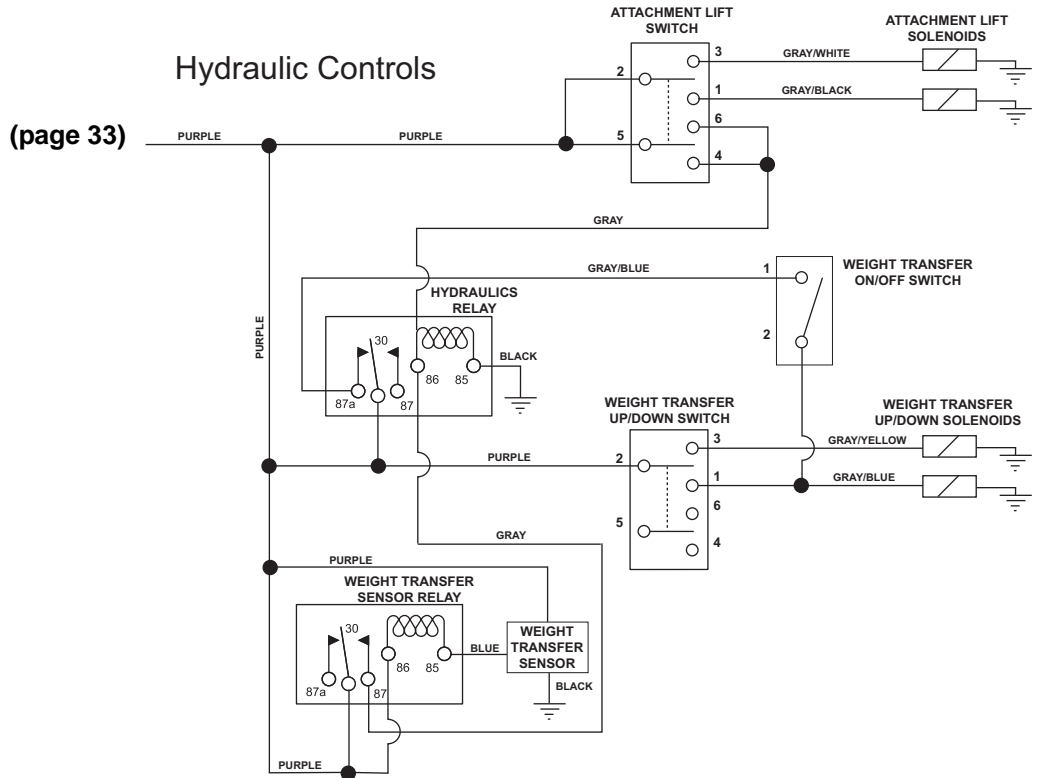



GRAVELY
655 West Ryan Street
Brillion, WI 54110-1072
920-756-2141
Fax 920-756-2407
www.gravelly.com